

BASKETS TOOLING

MT150A

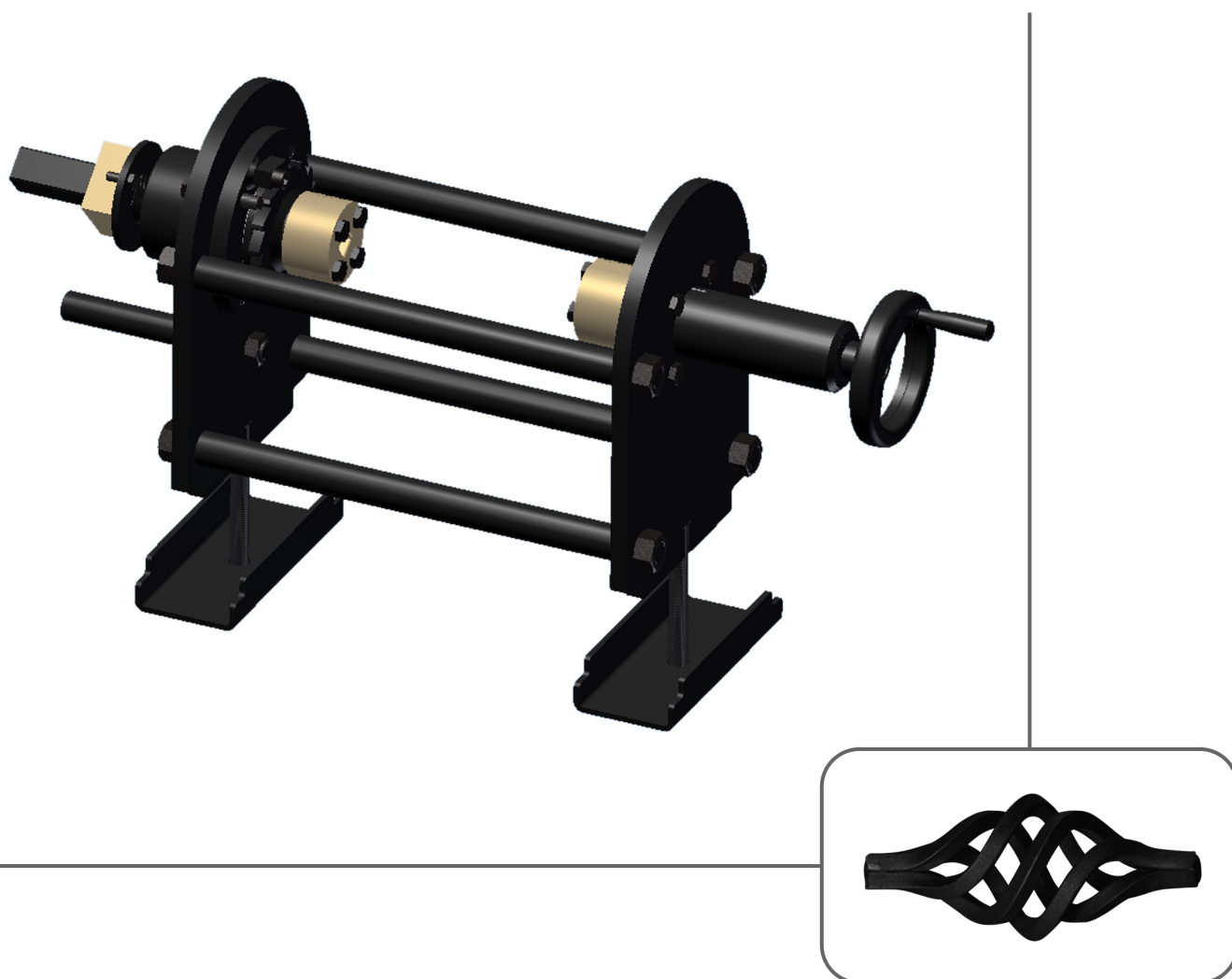

INSTRUCTIONS BOOK

PRADA NARGESA, S.L

Ctra. de Garrigàs a Sant Miquel s/n · 17476 Palau de Santa Eulàlia (Girona) Spain

Tel. +34 972568085 · nargesa@nargesa.com · www.nargesa.com

I N D E X

1. DESCRIPTION	2
2. CHARACTERISTICS	2
3. IDENTIFICATION OF THE TOOLING PARTS	2
4. ASSEMBLING	3
4.1. Mechanizing of the fastening holes	4
5. INSTRUCTIONS FOR USE	4
5.1. Manual Mode	5
5.2. Automatic Mode	6
6. MAINTENANCE	7
7. LIST OF PARTS	8

1. DESCRIPTION

The Baskets Tooling, as its name indicates, will allow the user to make a forge design known as "Basket". It is a shape compound of a number of bars which may vary according to the design and which is to be twisted and compressed making a scroll in the opposite direction to the first scrolling operation.

2. CHARACTERISTICS

The maximum sizes the user will be able to twist by using the baskets tooling for the MT150 are four (4) 10mm square bars together, whenever it comes to the base material as mild steel (45Kg/mm²). The bars maximum length is 205mm.

3. IDENTIFICATION OF THE TOOLING PARTS

Before proceeding with the assembling of the tooling pieces in the twisting machine MT150 we'll identify the most important parts of it so we can later on do a correct mounting and a proper further use.

As we can see in Picture 1 the parts will be identified as follows:

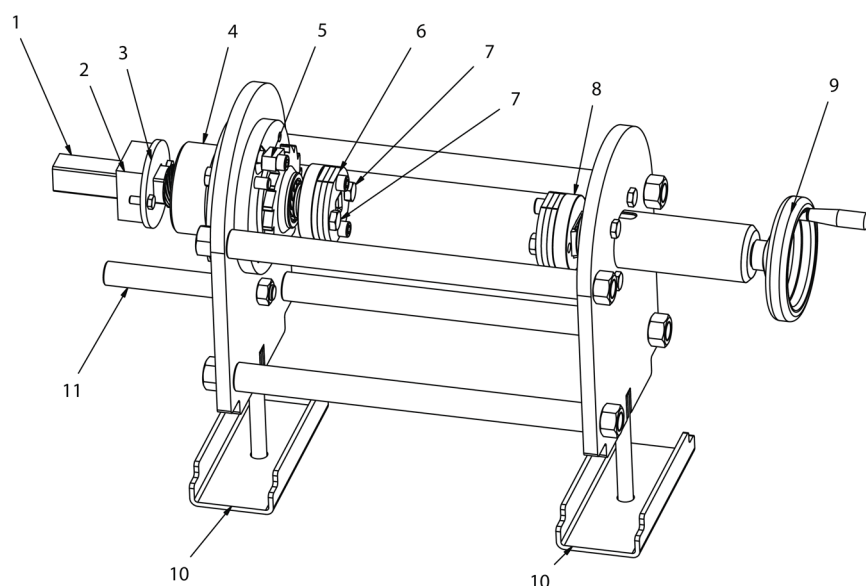

- 1 Main Drive Axis.
- 2 Traction square bar.
- 3 Fastening washer.
- 4 Manual traction.
- 5 Ratchet.
- 6 Driving groups.
- 7 Fastening screws for driving groups.
- 8 Fixed axis
- 9 Fastening wheel.
- 10 Fastening wheel.
- 11 Front gauge.

Picture 1

4. ASSEMBLING

To start up with the assembling the baskets tooling it is necessary to connect the MT150A/R to the line tension and in the case of the MT150A it is required to make an initialisation as it explained on the machine handling book.

Once we have the machine started and with the initialisation made we then proceed to assemble the tooling on the bench of the machine.

We place the traction square bar (2) on the head of the machine and we fasten it by using the fastening washer (3), this will enable the user to make a steady and safe job since he doesn't have to worry about the traction square bar. In order to fasten the washer, it is necessary to use two screws provided along with the tooling on the holes made in the head.

NOTE:

In case the twisting machine MT150 A/R doesn't have those holes, the user will have to make them by following the procedure exposed on section 4.1

Then the baskets tooling must be moved to the head inserting the main drive axis (1) in the traction square bar (2) if they are not symmetrically aligned then it is required to turn the main axis up to achieve this. It is then when we make the main axis turn until the front gauge (11) reaches the machine structure and we fasten the tooling by using the nuts and the clamping parts (10).

4.1. Mechanizing of the fastening holes

Should the twisting machine does not have the holes to fix the fastening washer (3) the user will have to mechanize them by following the process indicated below:

We'll place the basket tooling as it is indicated in the previous section, once it is mounted in the traction square bar (2), we'll put the fastening washer (3) in the Main drive Axis (1), we move the tooling to the head and present the main drive axis (1) to the traction square bar (2), it is then when we put the fastening washer (3) touching the head of the machine and being helped by a marker or some similar so we can mark the holes centres. Then we dismantle the tooling and we make the holes by using a drill so they can be screwed to M8 and with 15mm nut depth. Once this has been done we can go on mounting the baskets tooling.

5. INSTRUCTIONS FOR USE

Before using the baskets tooling it will be necessary to prepare the material to work with. As we have previously indicated in section 2, the maximum length of this material will be 205mm and it will be put together until a bigger square bar is obtained (in case the user wants to make the basket with thin square bars or four threads). In order to obtain this the bars must be welded on their extremes.

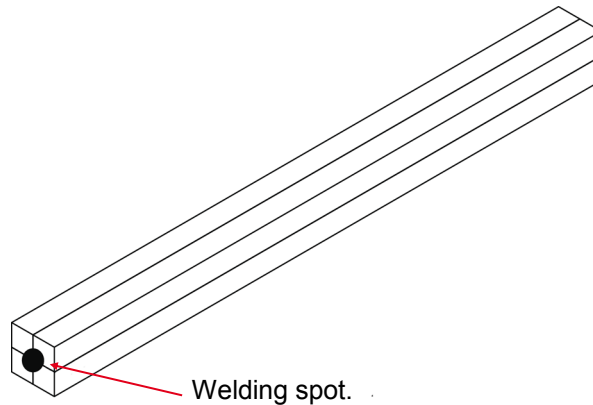

Once we have the material ready and the tooling set in the machine, we place the driving groups (6) we need according to the bar we are going to use and we fasten them by using the Fastening screws for the driving group(7). As a reference, the driving groups have some flat zones that enable us to have them aligned. We mount one in the main driving (1) and the other one in the Fixed Axis (8) which is driven by the wheel (9) located at the right of the tooling, if the driving groups(6) are not aligned, we can make the machine drive turn to the right or to the left according to our needs, always bearing in mind to be cautious to lift the ratchet (5) to release the screw.

Once we have the Driving groups aligned we'll proceed to place the bars inside the Driving group casing (6) and we'll make these bars fasten by using the Fastening wheel (9) we'll make the bars to be fixed between the Driving groups and then we'll place the ratchet (5) back into its starting position .

WARNING:

Before inserting the bars inside the Driving group, it is necessary to grease the casing to ease up the take out process.

Once we're at this point we can make the baskets in two different ways: in Manual Mode or Automatic Mode. Next we are going to explain both procedures.

5.1. Manual Mode

In order to make a basket in Manual Mode and get the references, first of all we ought to move the millimetre scale on the head manually until it coincides the zero (0) with the central mark. To get this we loose the pin from the millimetre scale and we make it turn with a hand. Then we fasten the pin again.

After this we make the drive turn the opposite direction to the ratchet (as it is indicated in picture 2, by using the button on the control panel and we note that the bars are being twisted; we make the twisting until approximately $\frac{3}{4}$ turn. Right after we make the drive turn in the opposite direction and we notice the ratchet (5) locks the crown and makes the main driving axis (1) moves inside undoing the twist and pressing the bars at the same time. We make this operation until the baskets obtain the size we desire. Once the basket is finished we make a short torsion in the opposite direction aiming at taking out the material from inside the driving groups (6). Finally we take off the bars by using the fastening wheel, we also lift the ratchet (5) and with the help of the Manual traction (4) we bring back the Main driving axis (1) to its original position.

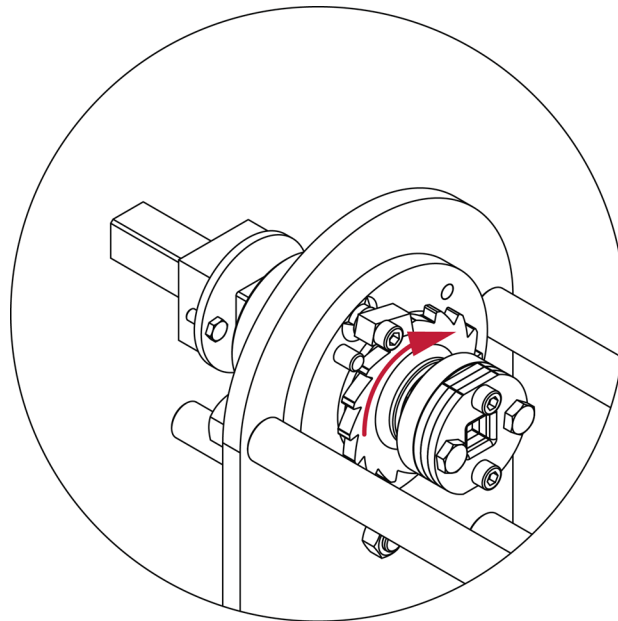



Picture 2

Manual mode is commonly used for making a few baskets since for making a great number of them and achieve them homogeneously it is more advisable to use the Automatic mode for achieving more.

5.2. Automatic Mode

Automatic mode for manufacturing baskets is used when we want to make a mass and even production of them. In order to make the programming we'll carry out the following steps:

- In case we have the machine automated, we'll proceed to make the whole initialisation as it is explained in its handling book.
- We place the main driving axis (1) in the starting position, that is to say, completely displaced towards the head of the machine and with the flat bar of the Driving group (6) in the upper part.
- We press the PROGRAM key on the control panel. 
- It will appear a label on the screen reading "Starting Point", since we already have the tooling in its starting position it won't be necessary to make any further action.
- Press the PROGRAM key to confirm the starting point. 
- Press the "Square type of torsion" key on the Control Panel. 
- We make the torsion to the required direction, using the turning keys to twist the bars up to the point we desire (Picture 2). There will appear two figures on the screen that will gradually increase, indicating the final position of the torsion ($\frac{3}{4}$ turn are son 90).
- Once the desired position is reached we press one number key from 1 to 8 which will be the number of the program.

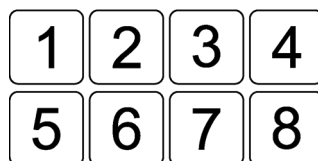

- After that it will appear a label on the screen reading "Take out" it is then when we press the turning button towards the opposite direction to the one previously made until we reach a position where the basket is completely shaped.
- We press the key in order to fix that point 
- It is then when programming the basket has been concluded.

- We will have to make a series of small back and forth movements with the turning buttons to get the material out of the driving groups (6).
- With the help of the fastening wheel (9) we'll get the fixed axis back (8) releasing the basket.
- We lift the ratchet (5).
- Press the number key where we have saved the basket program so the machine find automatically the starting point for the torsion.
- We take the main driving axis back up to its starting point by using the Manual traction (4).
- We place a new set of bars, fix it with the fastening wheel and we already have the machine about to start up a new basket as soon as we press the number key where we had saved the operation.

6. MAINTENANCE

The basket tooling has been designed and manufactured aiming at having an little maintenance tooling, it will be enough just with a regular greasing of the screw and the main driving axis(1). It is advisable that before each use the screw is cleaned, and right after using it should be greased as well.

NOTE:

Grease in excess is harmful since it might be contaminated with an excess of dust.

7. LIST OF PARTS

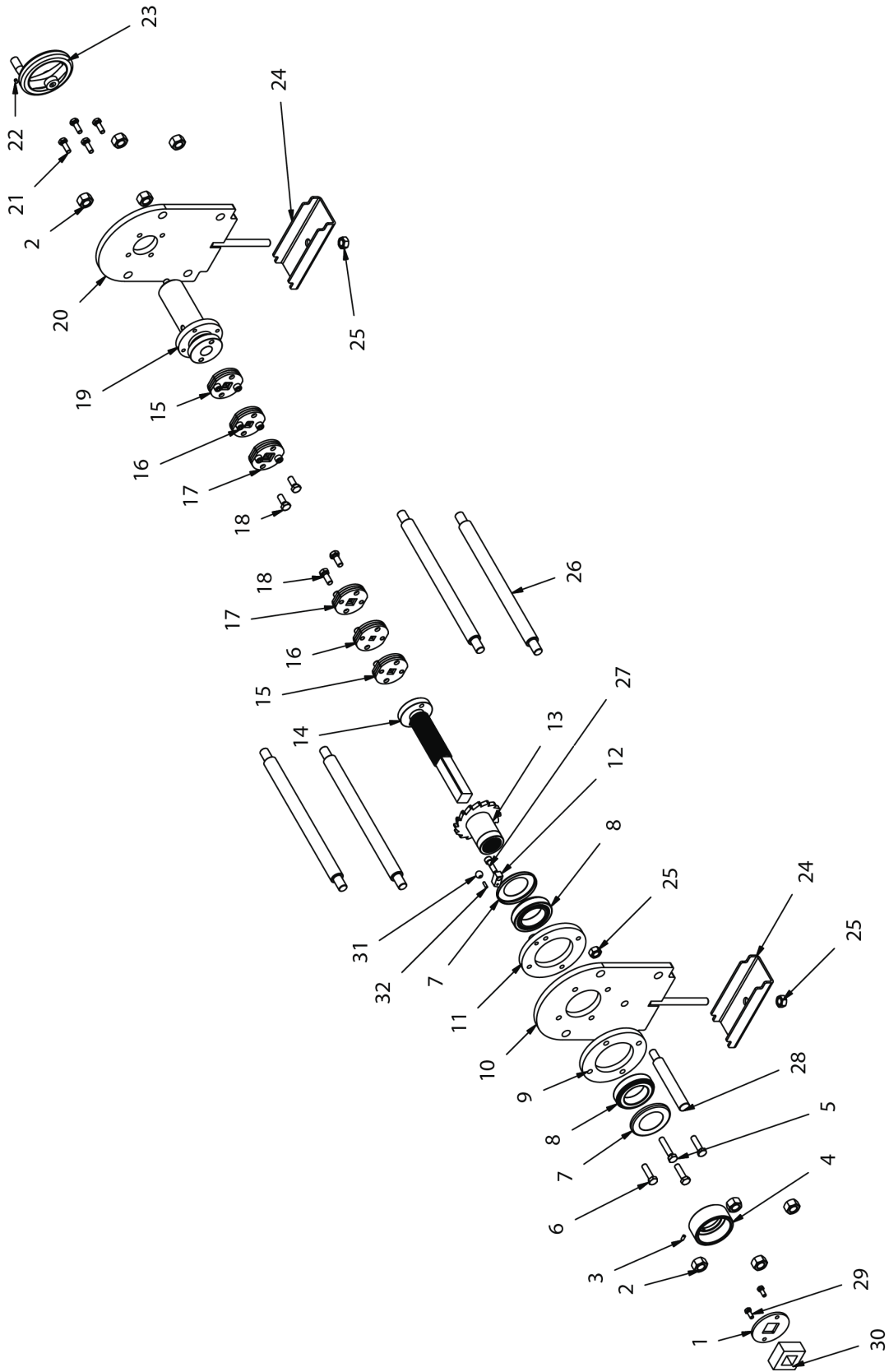

ELEMENTO	Nº	DESCRIPCION	CANTIDAD
1	125-01-01-00219	ARANDELA EJE CABEZAL	1
2	020-DIN934-M20	TUERCA DIN 934 M20	8
3	020-DIN913-M6X12	ESPARRAGO ALLEN DIN 913 M6X12	1
4	125-01-03-00215	TRACCION MANUAL	1
5	020-DIN933-M12X60	TORNILLO HEXAGONAL DIN 933 M12X60	1
6	020-DIN931-M12X45	TORNILLO HEXAGONAL DIN 931 M12X45 8.8	3
7	125-01-01-00222	TAPA COJINETES	2
8	030-CJ-32012-60X95X23	RODAMIENTO DE RODILLOS CONICOS 32012	2
9	125-01-01-00218	ARO PORTA COJINETE	1
10	131-01-01-00205	CONJUNTO PLACA DELANTERA	1
11	131-01-01-00208	ARO PORTA COJINETE EXTERIOR	1
12	125-01-01-00221	TRINQUETE	1
13	131-01-01-00200	CONJUNTO TUERCA	1
14	131-01-01-00212	CONJUNTO EJE TRACCION	1
15	131-01-01-00214	CONJUNTO TRACCION CUADRADO 8	2
16	131-01-01-00213	CONJUNTO TRACCION CUADRADO 6	2
17	131-01-01-00215	CONJUNTO TRACCION CUADRADO 10	2
18	020-DIN933-M12X30	TORNILLO HEXAGONAL DIN 933 M12X30	4
19	131-01-03-00200	CONJUNTO GUIA TRASERA	1
20	131-01-01-00206	CONJUNTO PLACA TRASERA	1
21	020-DIN933-M10X30	TORNILLO HEXAGONAL DIN 933 M10X30	4
22	020-DIN913-M6X10	ESPARRAGO DIN 913 M6X10	1
23	125-01-01-00224	VOLANTE ACCIONAMIENTO	1
24	125-01-01-00206	FIJACION INFERIOR	2
25	020-DIN934-M16	TUERCA DIN 934 M16	3
26	125-01-01-00204	VARILLA SEPARADORA	4
27	020-DIN912-M10X35	TORNILLO ALLEN DIN 912 M10 X35	1
28	125-01-01-00223	TOPE DELANTERO	1
29	020-DIN933-M8X20	TORNILLO HEXAGONAL DIN 933 M8X20	2
30	125-01-01-00228	ARRASTRE UTIL PIÑAS MT150	1