



# INSTRUCTIONS MANUAL

---

## CNC BENDING KIT

### MC550



---

PRADA NARGESA, S.L

Ctra. de Garrigàs a Sant Miquel s/n · 17476 Palau de Santa Eulàlia (Girona) SPAIN

Tel. +34 972568085 · nargesa@nargesa.com · www.nargesa.com

# NARGESA CLIENTS

Prada Nargesa has more than 8.000 customers around the world. Some of our clients, those who offer service to third parties with the Nargesa machinery in their workshops, have been pleased to be part of this network that aims to connect them with possible future clients. In this way, all those people or companies that have a need for any part or tool that can be manufactured by using the Nargesa range of machinery, will be able to find a solution in their area to be able to satisfy their production requirements by hiring their services.



**We have more than 8.500 customers in 150 different countries around the world**

Discover its location on the interactive map on our website!

## DO YOU WANT TO PARTICIPATE?

Send an email to [nargesa@nargesa.com](mailto:nargesa@nargesa.com), include the following information and we will add you to this list.

We want to encourage all those who haven't participated yet in this great commercial network!

1. Company name
2. CIF/Tax Code
3. City
4. Country
5. Machine or machines

# PRADA NARGESA

---

Prada Nargesa S.L. is a family business founded in 1970 located near Barcelona, Spain, with more than 50 years of experience in the sector of manufacturing of industrial machinery, and more than 10.000m<sup>2</sup> of facilities. Nargesa is a symbol of quality, reliability, warranty and innovation.

Our whole range of machines and accessories is manufactured entirely in Nargesa. We have a constant stock of 400 machines, and we have more than 16.800 machines sold all over the world.



## OUR RANGE OF MACHINERY

### Ironworker Machines

Ring Roller Bender and Pipe Bender  
Non-mandrel Tube and Pipe Bender  
Twisting / Scroll Bending Machines  
Horizontal Press Brakes  
End Wrought Iron Machines  
Gas Forges

### Iron Embossing Machines

Hydraulic Shear Machines  
Hydraulic Press Brakes  
Presses for Locks  
Broaching Machines  
Power Hammers

# CERTIFICATES

---

Prada Nargesa has several certifications that backup both, the design and manufacturing processes, as well as the journey through exporting our products around the world and the quality of the manufacturing components we use for our machines. These facts turn into real advantages for our customers:



## AUTHORIZED EXPORTER

- Faster customs procedures
- Reduction of tariff documentation
- Tariff preferences according to geographical location



## INNOVATIVE SME

- Development in innovation, design and manufacturing technologies
- Certification and audit of efficiency in product and service
- Ability to foresee customer needs



## R+D+I MANAGEMENT

- Manufacturing based on the R+D+I process
- Technological surveillance system

# SUCCESS STORIES

---

At Prada Nargesa we believe that the testimony of our clients is our best guarantee, and that is why we like to expose some of the success stories that we have witnessed around the world:



Discover its location on the interactive map on our website!

## DO YOU WANT TO PARTICIPATE?

Send an email to [nargesa@nargesa.com](mailto:nargesa@nargesa.com) including the following information and we will add you to our website:

- Company name
- Testimonial name
- Post in the Company
- Country
- Descriptive text
- Photography with the machine

## CONTENTS

<b>1. ACCESSORY DETAILS .....</b>	<b>3</b>
1.1. Accessory Identification .....	3
1.2. Dimensions .....	3
1.3. Accessory Description .....	4
1.4. General Characteristics .....	5
1.5. Machine Parts.....	5
1.6. Protectors and Support Mechanisms .....	6
<b>2. MOVEMENT AND STORAGE .....</b>	<b>7</b>
2.1. Movement .....	7
2.1.1. Box Contents .....	7
2.1.2. Unboxing Instructions .....	8
2.2. Storage Conditions .....	8
<b>3. MAINTENANCE .....</b>	<b>9</b>
3.1. Regular Cleaning .....	9
3.2. Lubrication .....	9
3.3. Recommendations .....	9
<b>4. INSTALLING THE CNC MC550 KIT .....</b>	<b>11</b>
4.1. Introduction .....	11
4.2. Installation Procedure .....	12
<b>5. ADJUSTMENTS .....</b>	<b>20</b>
5.1. Vertically Adjusting the Photoelectric Sensor Position.....	20
5.2. Horizontally Adjusting the Incremental Encoder Position .....	21
5.3. Changing the Position of the Photoelectric Sensor .....	21
<b>6. HOW TO ACTIVATE THE KIT .....</b>	<b>24</b>
<b>7. TECHNICAL ANNEXES .....</b>	<b>25</b>

## 1. ACCESSORY DETAILS

### 1.1. Machine Identification

<b>Make</b>	Nargesa
<b>Accessory type</b>	CNC BENDING KIT
<b>Model</b>	MC550

### 1.2. Dimensions

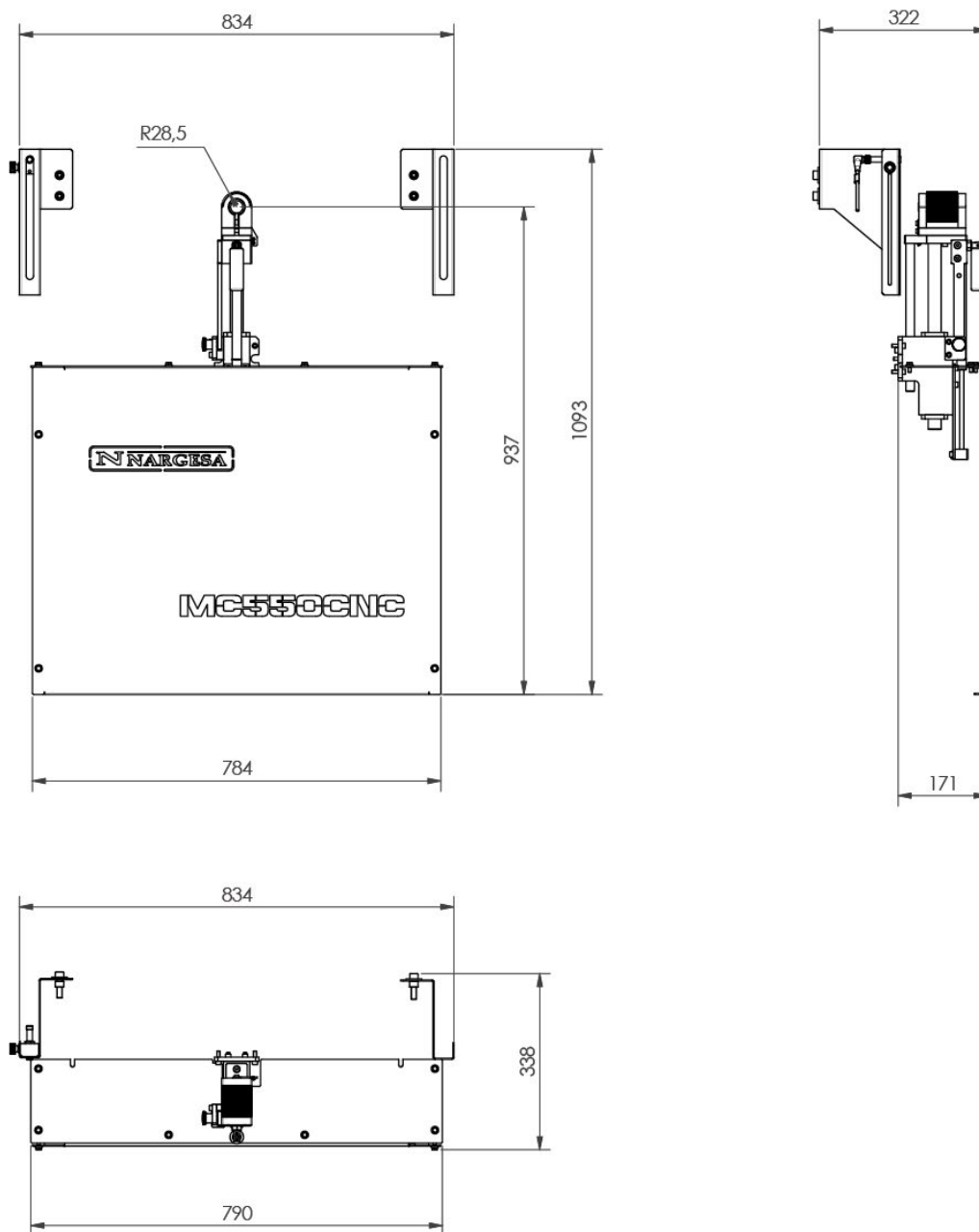

Figure 1. Outside dimensions of the MC550 bender

### 1.3. Accessory Description

The CNC MC550 kit is a comprehensive solution designed to optimize bending processes in MC550 machines with the integration of a robust mechanism and advanced software. Its characteristics, functions and key benefits are described below:

#### The main characteristics of the CNC MC550 Kit

- **Compact and robust design:** Ideal for demanding industrial applications.
- **Easy integration:** Quick and easy installation on MC550 bending machines.
- **Efficient automation:** Enables the production of small and large repetitive series of parts with high precision.
- **Improved productivity:** Increases the speed and reduces errors during operations.
- **High precision:** Guarantees uniform results with each part.

#### Main components

- **Cylindrical photoelectric sensor:**

- **Diffuse reflection:** Detects the presence of the material at a distance of up to 300 mm.

- **Adjustable sensitivity:** Guarantees a reliable and precise start to the production cycle.

- **Mini incremental encoder:**

- **High resolution:** Up to 4,096 pulses per turn, which enables precise positional control.

- **Continuous recording:** Monitors and measures the position of the pipes and profiles in real time, in addition to the forward and backward movements.

- **Gas spring:**

- **Power:** 200 N, designed to absorb irregularities in the materials.

- **Net run:** 160 mm, ensuring the encoder wheel remains in constant contact with the material, thus improving the reliability of each reading.

#### Benefits

- **Advanced automation:** Simplifies the production of complex parts by reducing manual intervention.
- **Flexibility:** Adapts to different batches from small prototypes to large mass productions.
- **Real-time optimization:** The continuous monitoring and data storage make it possible to make immediate adjustments to maximize the precision and efficiency.

This kit turns MC550 benders into highly productive machines, which are perfect for industrial environments requiring quality and consistent results.

**ATTENTION:** PRADA NARGESA S.L. is not liable for any damages that may be caused due to improper use or a breach of the safety rules by users.



**1.4. General Characteristics**

- Reference ..... **140-08-13-01000**
- Gas Spring Power..... **200N**
- Gas Spring Run ..... **160 mm**
- General Dimensions ..... **834x1093x338mm**
- CNC Kit Weight ..... **23 Kg**

**1.5. Machine parts:**

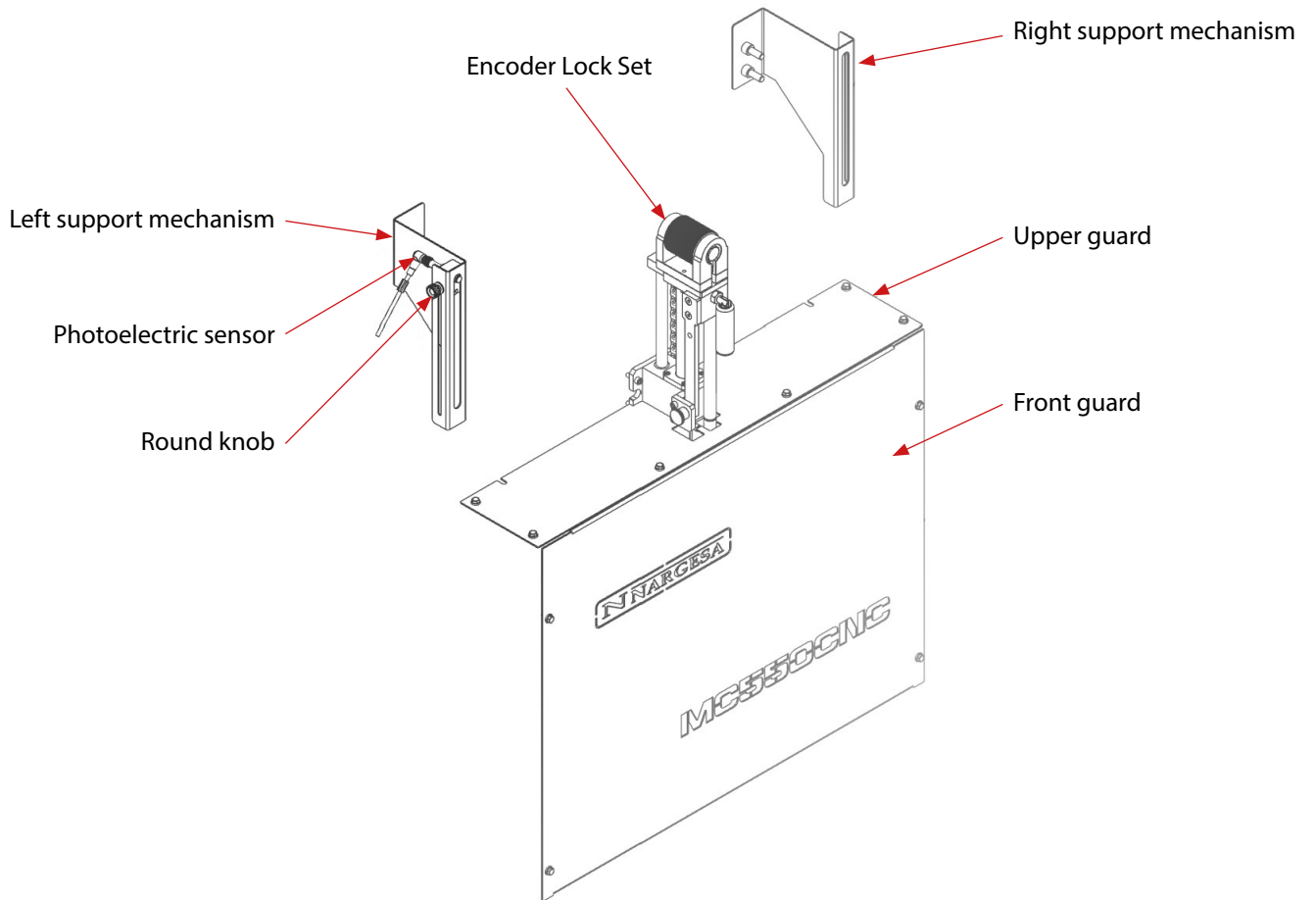

*Figure 2. CNC MC550 Kit Components*

## 1.6. Protectors and Side Support Mechanisms

The CNC MC550 Kit includes a set of guards designed to guarantee operator and equipment safety, as well as to enhance the versatility and maintenance of the system. These guards are:

- **Left support mechanism**
- **Right support mechanism**
- **Front guard**
- **Upper guard**

The side support mechanisms (left and right) offer key operational benefits. On the one hand, their design allows great versatility as they can be used with a wide variety of materials and profiles to be bent thanks to the vertical adjustment of the photoelectric sensor. On the other hand, they ensure high reliability by guaranteeing the proper position and functionality of the sensor during the production process by providing protection against possible impacts that may damage it.

The guards (front and top) prevent involuntary handling, entrapment, as well as the accumulation of impurities inside MC550 bending machines. Both guards can be easily and quickly removed for easier installation and maintenance work.

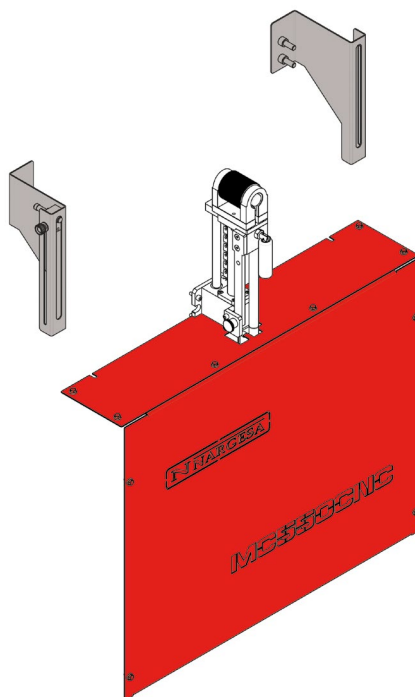

Figure 3. Mechanism protection guards

## 2. MOVEMENT AND STORAGE

### 2.1. Movement

The CNC MC550 Kit is carefully packaged in a resistant cardboard box specially designed to protect all the components during movement and storage. Before opening the box, it's important to ensure there is no visible damage which may occur during shipment. This ensures the Kit arrives in optimal conditions and any problems can be identified before use.

#### Important

If you notice any damage or imperfections on the box, do not open it. You must immediately contact the official technical service or our technical service directly to receive the necessary instructions and resolve the problem quickly and effectively.

#### 2.1.1. Box contents

- Check that all elements included in the box coincide with the list of parts in this manual.
- Handle the components with care to avoid damage.

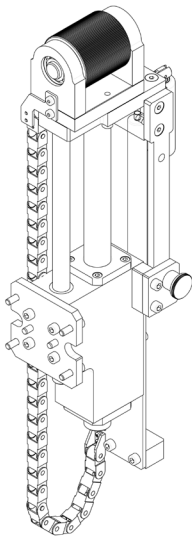

x1 Encoder set

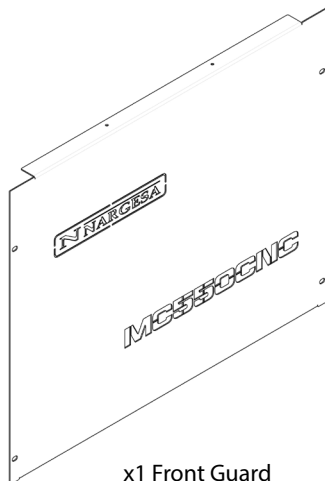

x1 Front Guard

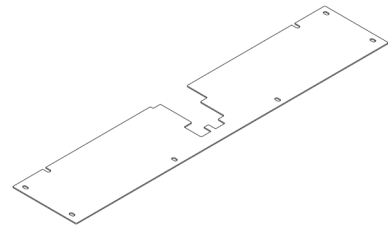

x1 Upper Guard

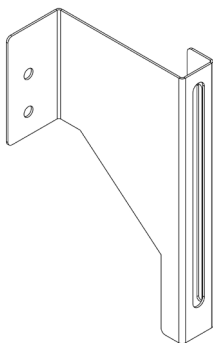

x1 Right support mechanism

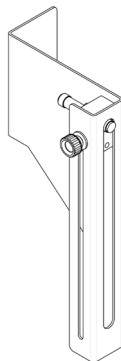

x1 Left support mechanism



x4 DIN 9021 M10 Washer



x4 Bushing



x10 M6x12 Flanged Hex-Head Screw



x4 DIN 912 M10x40 Allen Screw



x4 DIN 912 M6x20 Allen Screw

### 2.1.2. Unboxing Instructions

1. Place the box on a flat, stable surface.
2. Use a cutter or scissors to cut the tape.
3. Open the box carefully to avoid damaging the elements inside.

### 2.2. Storage Conditions

To guarantee the integrity of the CNC Kit components, follow these storage recommendations:

**1. Dry environment:** Store the Kit in a dry place to prevent exposure to moisture, which could damage the cardboard box or components inside. Relative humidity between 30% and 95%.

**2. Temperature:** Keep the Kit within a temperature range of 10-60°C. Avoid extreme temperatures.

**3. Ventilation space:** Store the Kit in a well ventilated space to prevent an accumulation of heat or moisture.

**4. Protection against impacts:** Make sure the storage space is free of risks of blows, falls or excessive pressure on the box.

Complying with these conditions will guarantee optimal conservation of the Kit until use.

### 3. MAINTENANCE

To guarantee proper functioning of the CNC MC550 Kit and extend the service life of all the components, mainly the moving parts, follow the maintenance steps below.

#### 3.1. Regular Cleaning

Clean all moving parts after each use or in accordance with the frequency specified in this manual, using a soft, dry cloth to remove dust, impurities or any accumulated residue. If necessary, use a slightly damp cloth or a recommended cleaning product. Avoid the use of abrasive or corrosive products.

#### 3.2. Lubrication

Keeping the moving parts in the encoder lock set clean of any impurities and well lubricated to reduce friction and prevent component wear. Clean any excess lubricant off to prevent an accumulation of dust and impurities. Lubricate at the intervals indicated below, depending on the intensity of use. A lack of optimal lubrication will significantly shorten the nominal life of some of the main components due to wear. The initial greasing of the guide system and all other moving parts was done at the Prada Nargesa facilities prior to packaging. Nonetheless, maintaining proper greasing is absolutely necessary and essential.

#### 3.3. Recommendations

- General cleaning and of all moving parts after each use.
- Grease the moving parts every 300 hours of operation or every 6 months.
- Use multi-purpose extreme pressure and low viscosity lithic grease.
- Do not use grease with molybdenum disulfide or graphite.
- Keep the bearing scrapers clean without any excess lubricant.

For environments with severe conditions of use and impurities, shorten the recommended greasing frequency by half.

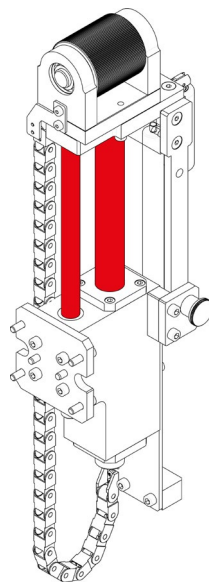

*Figure 6. Detailed view of the greasing areas*

- **Adjustments:** Check that the moving parts work fluidly without getting stuck. If necessary, contact the authorized technical service for questions. Check that the moving parts work fluidly without getting stuck. If necessary, contact the authorized technical service for questions.
- **Avoid overload:** Do not force the moving parts beyond their operational capability. An overload can cause premature wear or irreparable damage.
- **Spare parts and repairs:** Only use original spare parts and accessories recommended by the manufacturer. For questions or complex repairs, contact the authorized technical service or our technical service directly.

**ATTENTION:** PRADA NARGESA S.L. is not liable for any damages that may be caused due to improper use or a breach of the safety rules by users.

## 4. INSTALLATION OF THE CNC MC550 KIT

### 4.1. Introduction

The **CNC MC550 Kit** is supplied partially assembled inside the cardboard box, which allows for quick and easy installation, as well as efficient set-up on any MC550 machine. The user can do the entire process.

### Component Check

See section 2.1.1. **Box Content** of this manual to check that all components described in the list of detailed parts are included in the box received.

### Areas of the Machine:

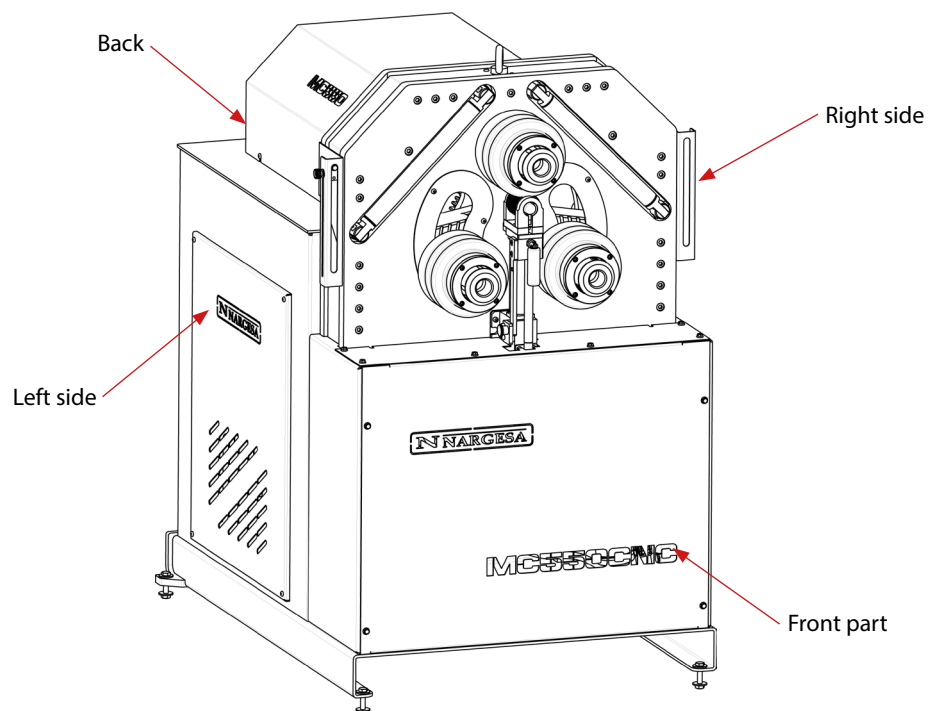

Figure 7. Detailed view of the machine areas.

### Important:

Check that all the necessary tools are available and the work area is clean and organized, free of obstacles, before starting the installation. Disorder can increase the risk of accidents.

- No. 4 Allen Wrench
- No. 5 Allen Wrench
- No. 8 Allen Wrench
- Ratchet Wrench
- No. 10 Cup for Ratchet Wrench
- Phillips Screwdriver
- Cable Tie Cutting Pliers

## 4.2. Installation Procedure

The steps to be followed for proper installation of the CNC Kit on a MC550 bending machine are described below:

### 1. Stop the MC550 bending machine

Turn the general switch to the **OFF position**

Press the **Emergency Stop button**

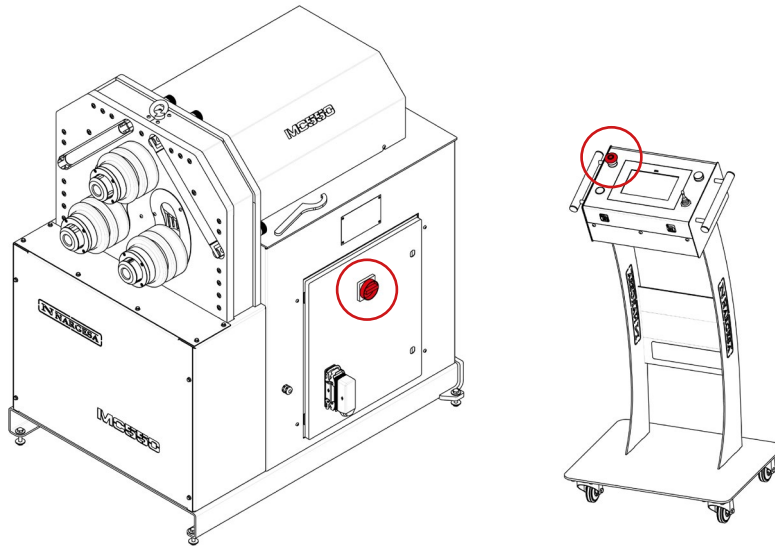

### 2. Remove the screws

Use a No. 8 Allen Wrench to loosen and remove the two DIN 912 M10x30 screws shown in the following image.

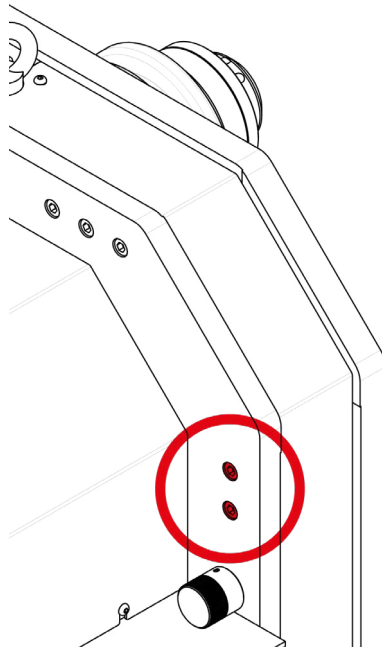



### 3. Insert bushings

Manually insert two of the four bushings supplied.

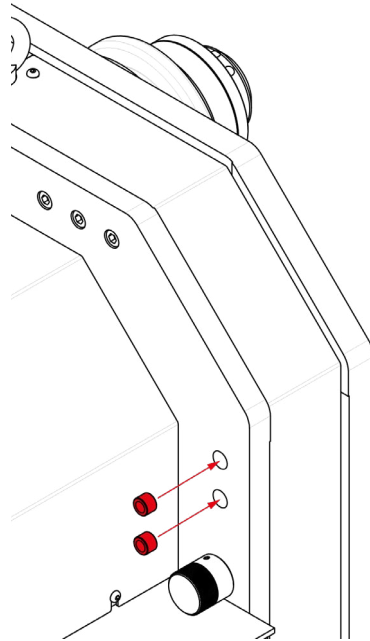

### 4. Assemble the side support mechanism

Remove the left support mechanism from the box.

Position it as shown in the following image.

Secure it to the MC550 frame using a No. 8 Allen Wrench and the two **DIN 912 M10x40** screws supplied.

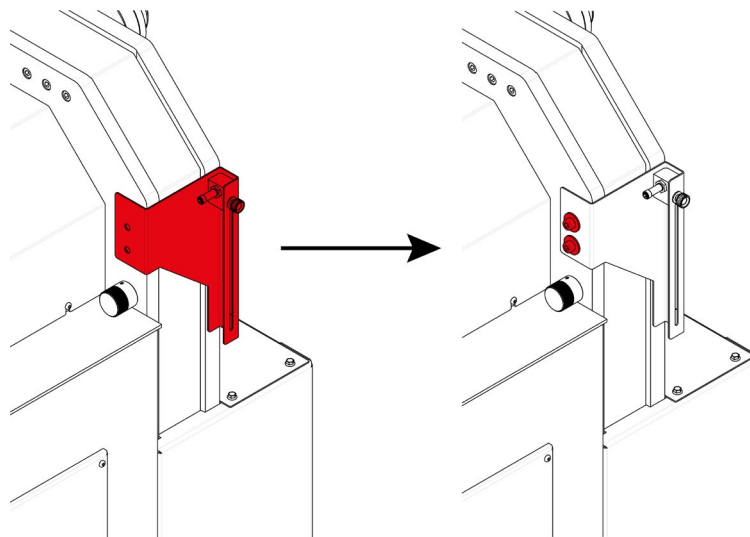

#### NOTE:

Repeat steps 2, 3 and 4 in this section of the manual on the right side of the machine.

By default, the photoelectric sensor is supplied assembled on the left side.

If the material enters on the left side of the MC550 bending machine, the photoelectric sensor must be assembled on the right side. See section 5. **Adjustments** in this manual to make this change.

### 5. Adjust the photoelectric sensor

Loosen the threaded knob on the left support mechanism.

Slide the sensor to the desired position.

Re-tighten the knob to secure the position.

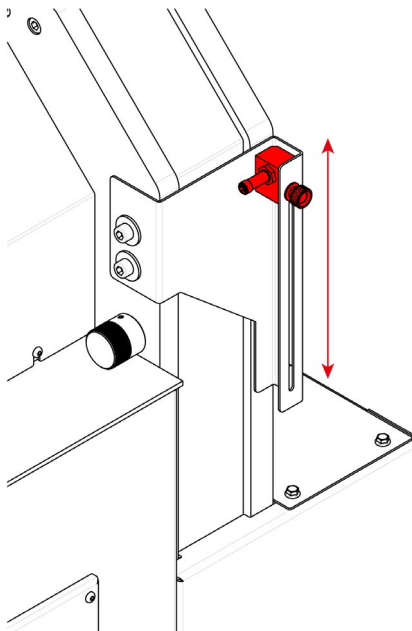

### 6. Remove the upper guard

Use a ratchet wrench and a No. 10 cup on the front of the machine.

Loosen the six DIN 6921 M6x12 screws

Remove the upper guard and store it so as not to hinder the installation work.

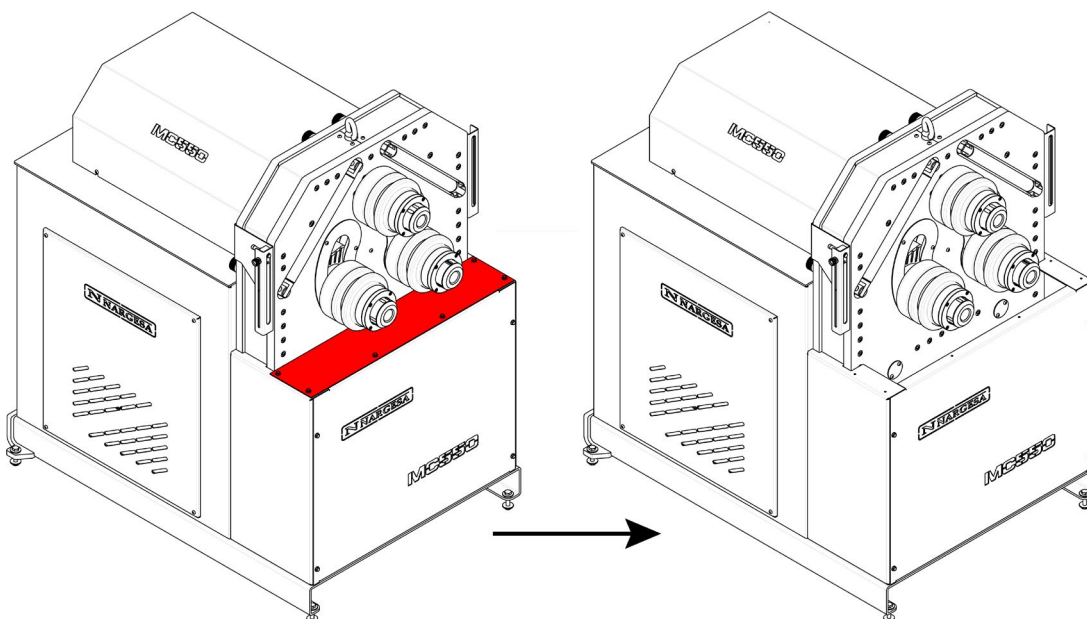

### 7. Remove the front guard

With the same ratchet wrench and a No. 10 cup, loosen the four DIN 6921 M6X12 screws securing the front guard. Remove the front guard and store it so as not to hinder the installation work.

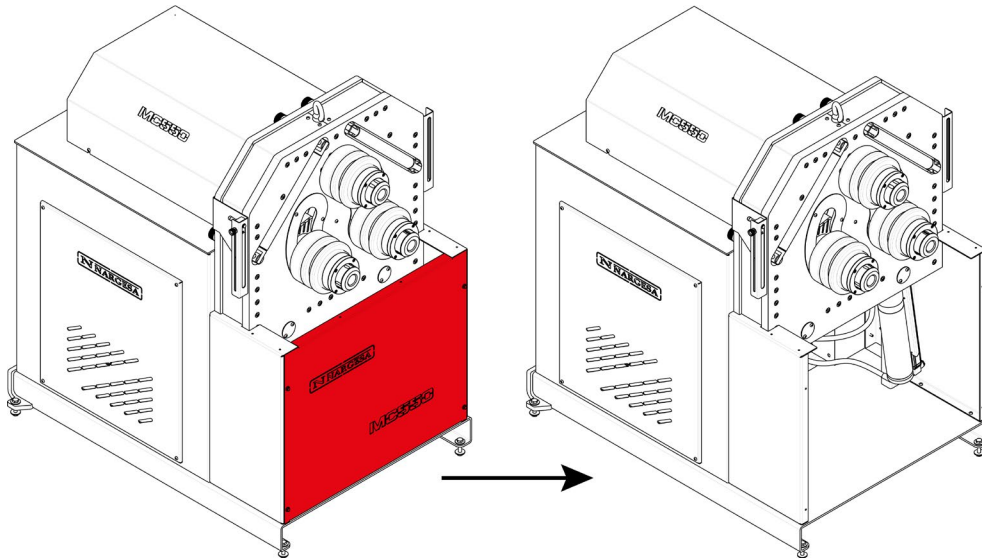

### 8. Remove the protective cover

Use a No. 4 Allen Wrench to loosen the four ISO 7380 M6x10 screws securing the protective cover in the frame area where the encoder lock set is to be secured.

Remove the cover if necessary using a screwdriver.

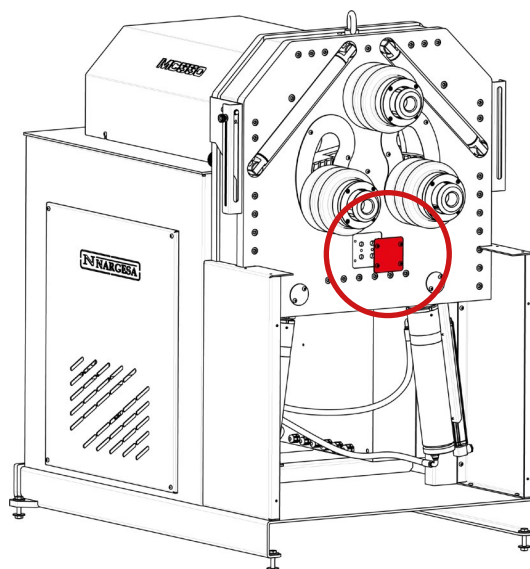

### 9. Release the signal cable

Use pliers to cut the cable ties securing the signal cable on the bottom of the machine under the two hydraulic cylinders. Place the end of the signal cable with the female connector on top of the left guard on the machine for later connection to the photoelectric sensor as described in step 12 of this same section.

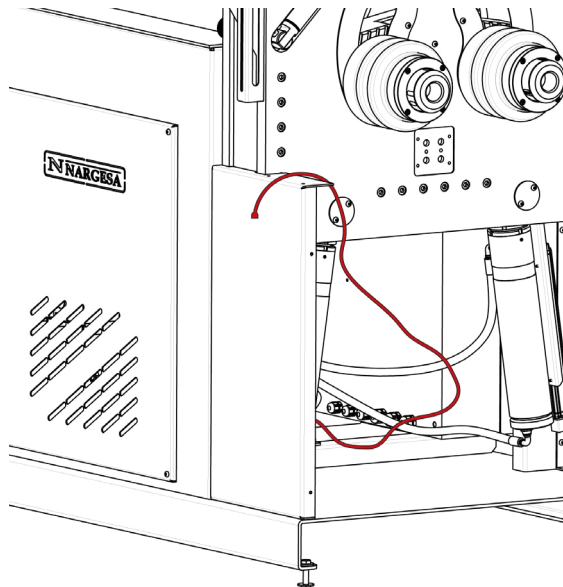

### 10. Assemble the encoder lock set

Remove the encoder lock set from the box with care.

**Attention:** There is a risk of flattening if it falls. Make sure to hold the set firmly while handling. If necessary, use the right equipment or ask for help.

Place the encoder lock set in the frame area on the MC550 machine where the protective cover was removed (see step 8). Check that the contact surfaces are clean and free of residue before positioning.

Align the holes on the encoder lock set with the frame. Use a No. 5 Allen Wrench and secure the set with the four DIN 912 M6x20 screws supplied. Make sure to tighten the screws cross-wise to guarantee they are even and secure.

Check that the set is firmly secured and there are no movements or vibrations. Visually check to ensure no parts are poorly adjusted or out of place.

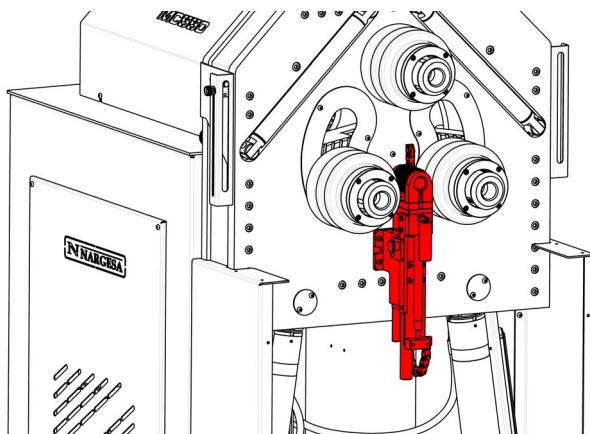

**11. Connect the incremental encoder cable**

Connect the end of the signal cable on the encoder lock set to the end of the signal cable at the bottom of the machine, also below the hydraulic cylinders.

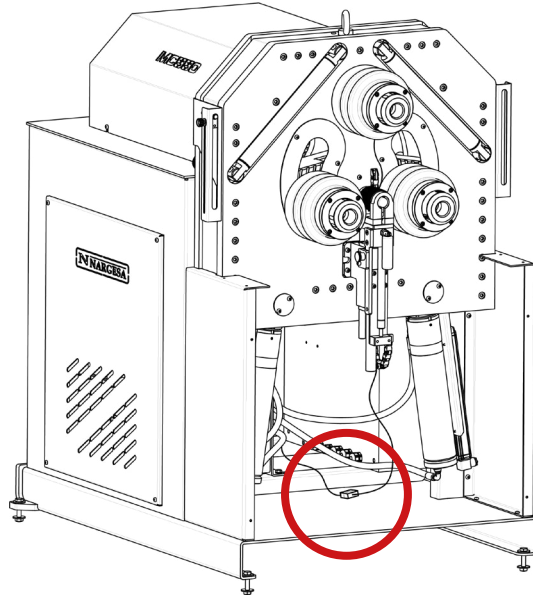
**12. Connect the photoelectric sensor**

Connect the end of the signal cable to the photoelectric sensor.

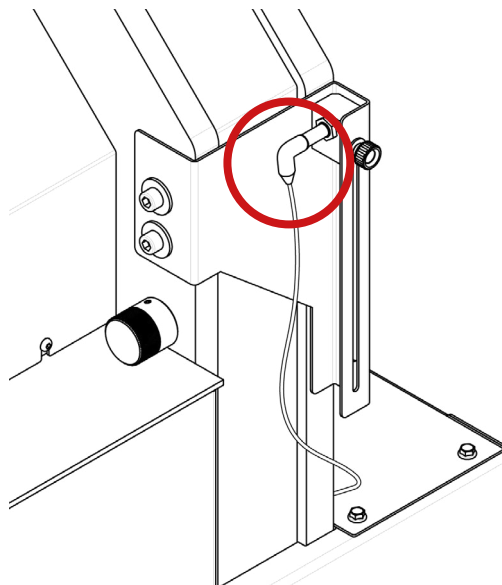

### 13. Assemble the front guard

Locate the handle on the encoder lock set and move it to the active position.

Place pressure on the handle and activate the retractable knob at the same time to release the mechanism from the locked state.

**Attention:** The gas spring will push the roller housing the incremental encoder up until it collides with the fixed upper roller.

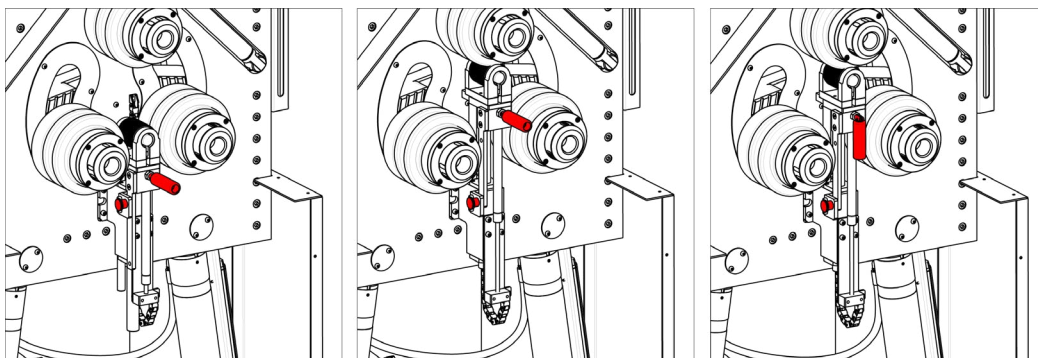

Remove the new front guard from the packaging. Inspect it visually to ensure there is no damage before installation. Place the front guard in the corresponding position as shown in the following image.

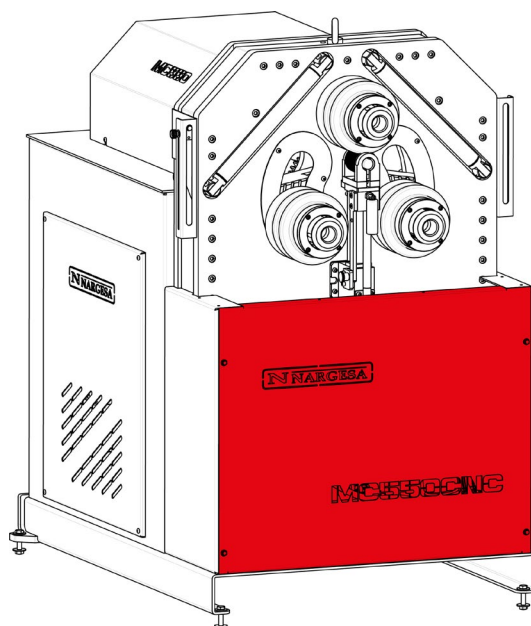

Use the four **DIN 6921 M6x12** screws supplied to secure it. Check that it does not interfere with the functioning of any other machine components.

#### 14. Assemble the upper guard

Remove the new upper guard from the box. Inspect it to ensure there is no damage before installation. Place the top guard in the corresponding position as shown in the following image.

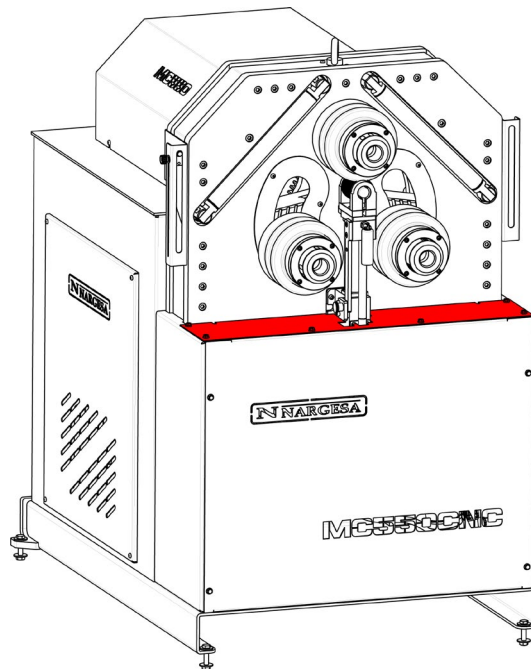

Use the six DIN 6921 M6x12 screws supplied in the bag to secure it.

**Attention:** Check that the signal cable on the photoelectric sensor passes through the left groove on the upper guard. If not, move it manually until it passes through this groove.

**ATTENTION:** In order for the upper guard to be assembled on the machine, the roller housing the incremental encoder must be in contact with the fixed upper roller, as shown in this image:

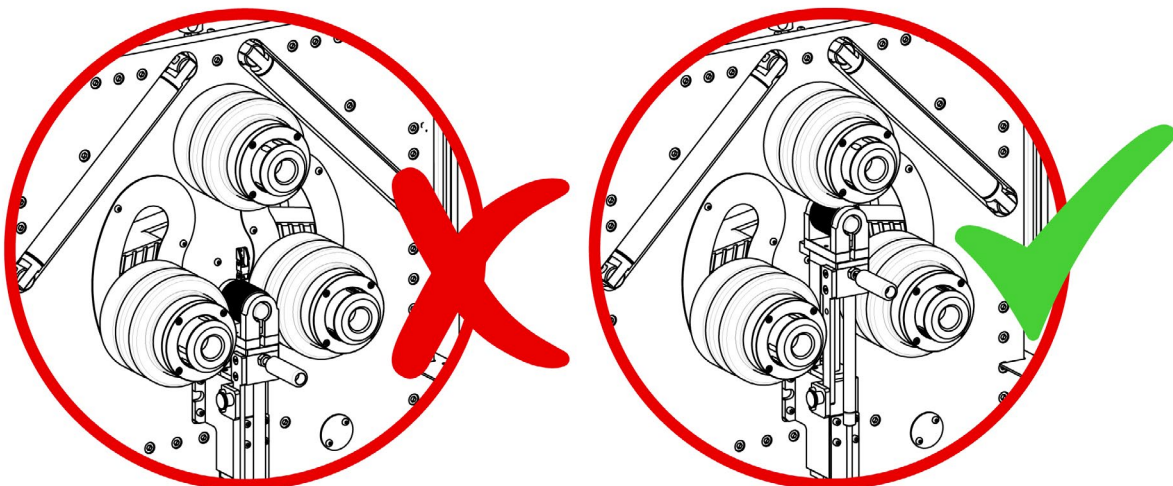

## 5. ADJUSTMENTS

To correctly configure the CNC MC550 Kit and adapt it to the profiles and sizes of the materials to be bent, three main adjustments and verifications must be done. The basic steps for each one are described below.

### 5.1. Vertically Adjusting the Photoelectric Sensor Position

To properly adjust the position of the photoelectric sensor on any of the two side support mechanisms installed on the bending machine, you need to follow these steps:

Identify the threaded knob securing the photoelectric sensor to the left support mechanism.

Turn the knob counter-clockwise to loosen it.

**Attention:** If you loosen the knob too much, it may fall along with the washer and the square lock where the photoelectric sensor is assembled, which may damage it. Loosening and unscrewing the knob just enough to allow the sensor square lock to slide along the side support mechanism is recommended.

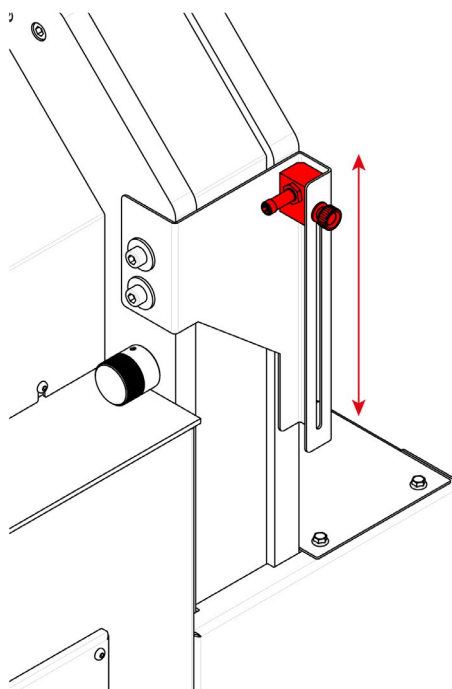

Slide the square lock along the side support mechanism until it's in the position where the photoelectric sensor can detect the profile to be used in the bending process.

Check that the sensor location complies with the work to be done, such as the detection distance and the coverage area. The sensor has an orange LED which stays on when both conditions (detecting the profile and remaining at the right distance) are met.

Check that the LED is on to confirm the sensor is correctly positioned.

Once the sensor is in the correct position, rotate the threaded knob clockwise to tighten it and prevent it from sliding during the bending process.



## 5.2. Horizontally Adjusting the Incremental Encoder Position

Profiles can be bent with MC550 bending machines in multiple shapes and sizes. To be able to monitor and measure the position of the profiles in real time, as well as the forward and backward movements, the CNC Kit roller housing the incremental encoder must always be in contact with the profile to be bent. Depending on the size and type of profile, the horizontal position of this roller may need to be adjusted as described below:

Use a No. 5 Allen Wrench to loosen and remove the two DIN 912 M6x25 screws shown in the following image.

Slide the upper subset until the roller that houses the incremental encoder is in a position that guarantees it will remain in constant contact with the profile to be bent.

Use a No. 5 Allen Wrench and re-tighten the two DIN 912 M6x25 screws and secure the subset.

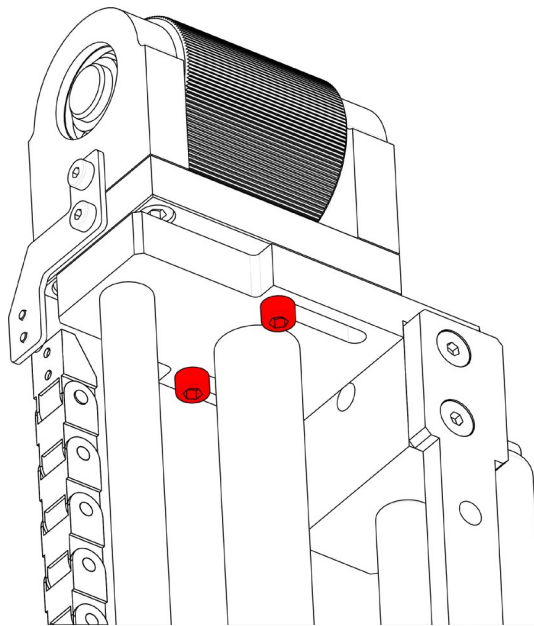

## 5.3. Changing the Position of the Photoelectric Sensor

The photoelectric sensor plays a crucial role on MC550 bending machines by detecting and controlling the material feed. Depending on whether the material enters on the left or right side of the machine, the sensor must be assembled and configured on the corresponding support mechanism to guarantee proper functioning.

The necessary steps to change the position of the photoelectric sensor from right to left or vice versa are detailed below:

1. Turn off the machine before doing anything in order to prevent risks or damage.
2. Identify on which side the material is fed. Determine on which side the material to be bent in the MC550 machine will be inserted:
  - If the material enters on the left side of the machine, the sensor must be assembled on the right side.
  - If the material enters on the right side of the machine, the sensor must be assembled on the left side.
3. Identify on which side support mechanism the photoelectric sensor is secured and disconnect the signal cable powering it.
4. Check that the roller housing the incremental encoder is in constant contact with the fixed upper roller, as shown in the following image. This is an essential condition for the upper guard to be dismantled. If the roller is not in this position, locate the handle on the encoder lock set and move it to the active position. Place pressure on it and activate

the retractable knob at the same time to release the mechanism from the locked state. Attention: The gas spring will push the roller up until it collides with the fixed upper roller.

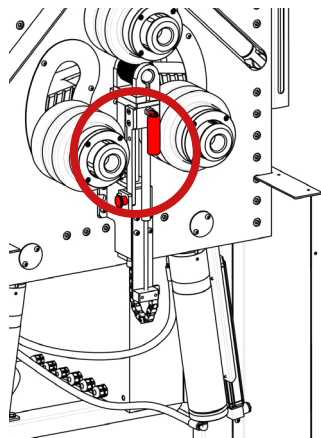

5. Remove the upper guard by loosening the six DIN 6921 M6X12 screws using a ratchet wrench and a No. 10 cup.

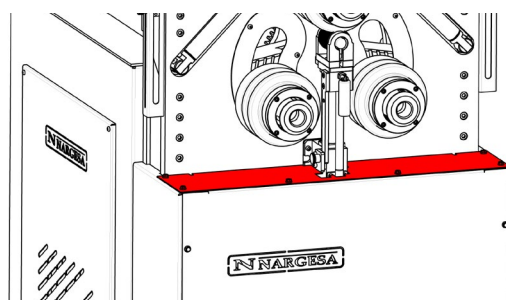

6. Turn the knob counter-clockwise to loosen it, and remove it along with the wide washer accompanying it. **Attention** because the square lock where the photoelectric sensor is threaded may fall and the photoelectric sensor may become damaged. Unscrewing the knob gradually securing the square lock at all times is recommended.

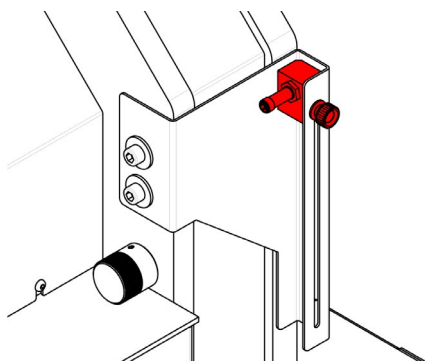

**7.** Place the square lock in the opposite support mechanism (left to right, or vice versa) and secure it to the new side support mechanism with the knob and washer.

**8.** Connect the signal cable again to the photoelectric sensor.

**9.** Place the upper guard in the correct position and secure it with the six DIN 6921 M6x12 screws.

**Attention:** Check that the signal cable on the photoelectric sensor passes through the closest upper guard groove. If not, move the cable manually with your hand until it passes through this groove.

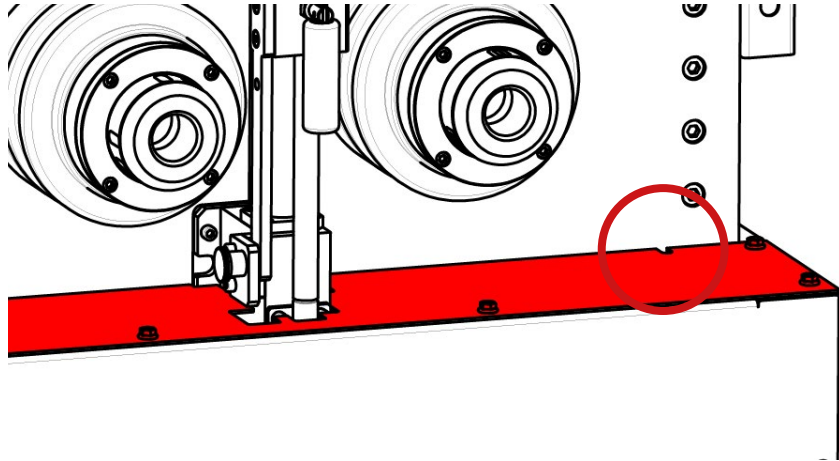

**10.** Adjust the vertical position of the photoelectric sensor if necessary by following the steps detailed in section 5.1 of this manual.

## 6. HOW TO ACTIVATE THE KIT

Once the CNC Bending Kit is assembled on the MC550 Bending Machine, you must activate it in the machine software so it detects the accessory.

1. Plug the network cable supplied with the machine into the Ethernet connector on the top of the control panel.

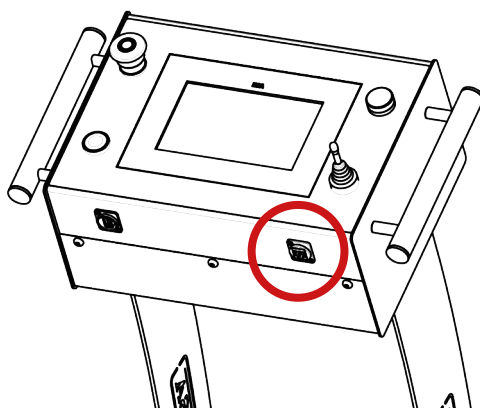

2. Connect the other end of the cable to a computer with an Internet connection.

3. Open the Nargesa website [nargesa.com](http://nargesa.com) and go to the SAT menu at the top.

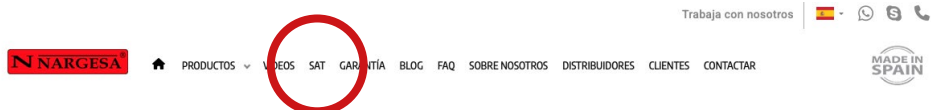

4. Contact the Nargesa technical service.

By phone at +34 972568085

By email at [sat2@nargesa.com](mailto:sat2@nargesa.com)

They will provide the instructions for remotely connecting to the machine and then do the proper adjustments. They will also provide the instructions for making any pertinent adjustments to the machine variators.

**7. TECHNICAL ANNEXES**

**A1. General Exploded View of the CNC MC550 Kit**

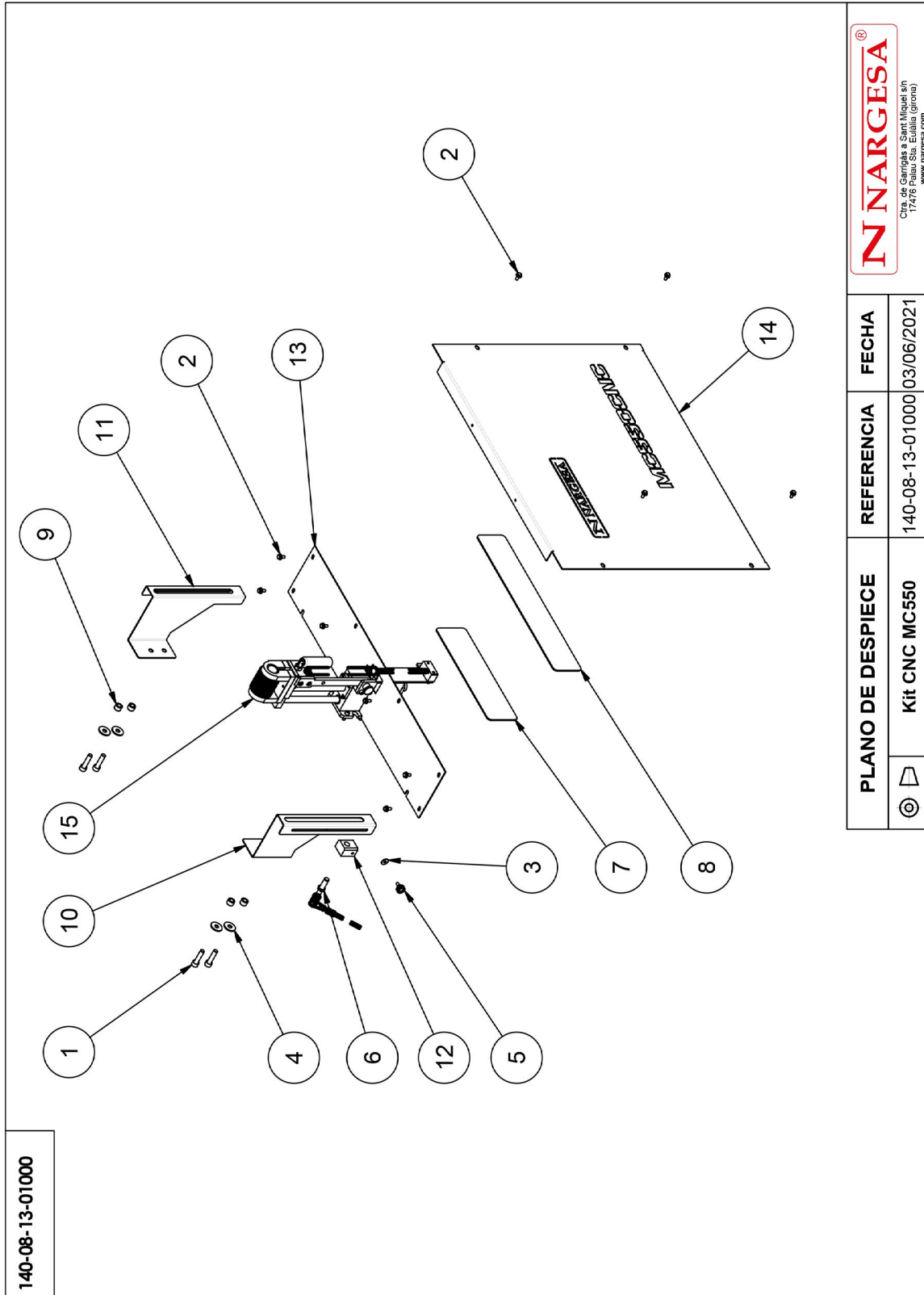

	<b>PLANO DE DESPIECE</b>	<b>REFERENCIA</b>	<b>FECHA</b>
	Kit CNC MC550	140-08-13-01000	03/06/2021

**N NARGESA®**  
 Ctra. de Garrigàs a Sant Miquel s/n  
 17476 Palaus Soler, Eulàlia (Girona)  
 www.nargesa.com

Este plano es propiedad de Frade Nargesa SL. No podrá ser reproducido, comunicado a terceros o utilizado para otro fin que no sea el acordado sin su permiso escrito.

Elemento	Miniatura	Nº de pieza	Descripción	CTDAD
1		020-D912-M10X40	TORNILLO ALLEN DIN 912 M10X40	4
2		020-D6921-M6X12	Tornillo Hexagonal Embridado M6X12	10
3		020-D9021-M6	Arandela Ancha DIN9021 Para M6	1
4		020-D9021-M10	Arandela DIN 9021 M10	4
5		031-POMM-00011	POMO REDONDO D20 M6X10	1
6		050-IND-00006	DETECTOR DIELL M12 PNP DM7/OP-1H	1
7		120-08-12-00081	Metacrilato Negro Tapa Frontal Logo Nargesa	1
8		120-08-12-00082	Metacrilato Negro Tapa Frontal Logo MC650	1
9		125-08-13-01020	Casquillo Distanciador	4
10		125-08-13-01021	Soporte Sensor Fotoeléctrico	1
11		125-08-13-01022	Soporte Sensor Fotoeléctrico	1
12		125-08-13-01023	Dado Guiador	1
13		125-08-13-01024	Tapa Superior Cubierta	1
14		125-08-13-01025	Tapa Frontal MC550 CNC	1
15		131-08-13-01000	Conjunto Encoder / Sensor Fotoeléctrico	1

**A2. Exploded View of the Encoder Lock Set**

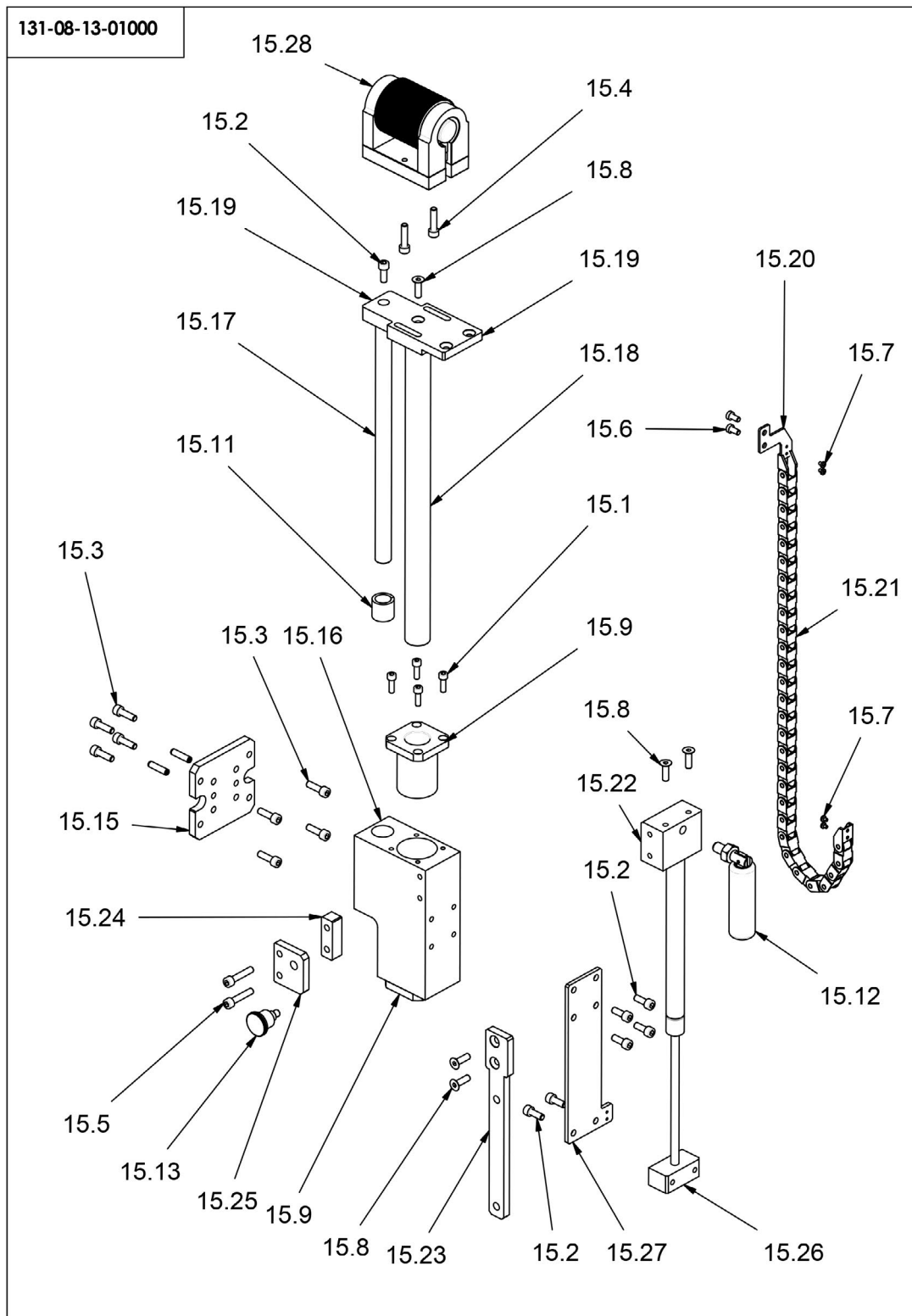



PLANO DE DESPIECE		REFERENCIA	FECHA
	Conjunto Encoder / Sensor Fotoeléctrico	131-08-13-01000	15/09/2023

**N NARGESA®**  
 Ctra. de Garrigás a Sant Miquel s/n  
 17476 Palau Sta. Eulàlia (Girona)  
 www.nargesa.com

Este plano es propiedad de Prada Nargesa SL. No podrá ser reproducido, comunicado a terceros o utilizado para otro fin que no sea el acordado sin su permiso escrito.

Elemento	Miniatura	Nº de pieza	Descripción	CTDAD
15.1		020-D912-M5X16	TORNILLO ALLEN DIN 912 M5X16	8
15.2		020-D912-M6X16	Tornillo Allen DIN912 M6X16	7
15.3		020-D912-M6X20	Tornillo Allen DIN912 M6X20	8
15.4		020-D912-M6X25	Tornillo Allen DIN912 M6X25	2
15.5		020-D912-M6X30	Tornillo Allen DIN912 M6X30	2
15.6		020-D7984-M5X10	Tornillo Allen Cabeza Reducida Din7984 M5X10	2
15.7		020-D7985-M3X4	Tornillo DIN7985 M3X4 Philips	4
15.8		020-D7991-M6X20	Tornillo Allen Avellanado DIN7991 M6X20	5
15.9		030-CJ-00047	Cojinete Deslizamiento Lineal con Brida Cuadrada Ref. KBK 25-PP	2
15.10		030-D7979D-00009	Pasador Cilindrico Con Rosca Int. DIN7979/D D6X24	2
15.11		030-DP-00010	Casquillo Bronce D16xD22x20	2
15.12		031-MAP-00001	Manilla Giratoria Plegable 136 M10x15	1
15.13		031-POS-00013	MINI POSICIONADOR DE MUELLE SIN BLOQUEO Ø7 - M10X1	1
15.14		031-RGC-00002	ESORTE DE GAS LIFT 8/18 FUERZA 200 N CARRERA 160 mm REF. 08 400 20	1

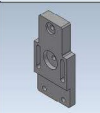

Elemento	Miniatura	Nº de pieza	Descripción	CTDAD
15.15		125-08-13-01007	Placa Fijación	1
15.16		125-08-13-01008	Soporte Principal	1
15.17		125-08-13-01009	Eje Guiado Posterior	1
15.18		125-08-13-01010	Eje Guiado Frontal	1
15.19		125-08-13-01011	Base Fijación Conjunto Encoder	1
15.20		125-08-13-01012	Fijación Trasera Cadena Portacables	1
15.21		125-08-13-01013	Cadena Portacables Serie 05	1
15.22		125-08-13-01014	Tope Fijación Resorte Gas	1
15.23		125-08-13-01015	Pletina Guiado Posicionador	1
15.24		125-08-13-01016	Grueso Soporte Posicionador	1
15.25		125-08-13-01017	Soporte Posicionador	1
15.26		125-08-13-01018	Tope Fijación Resorte Gas	1
15.27		125-08-13-01019	Placa Soporte	1
15.28		131-08-13-01001	Conjunto Encoder	1

A3. Exploded View of the Encoder Roller

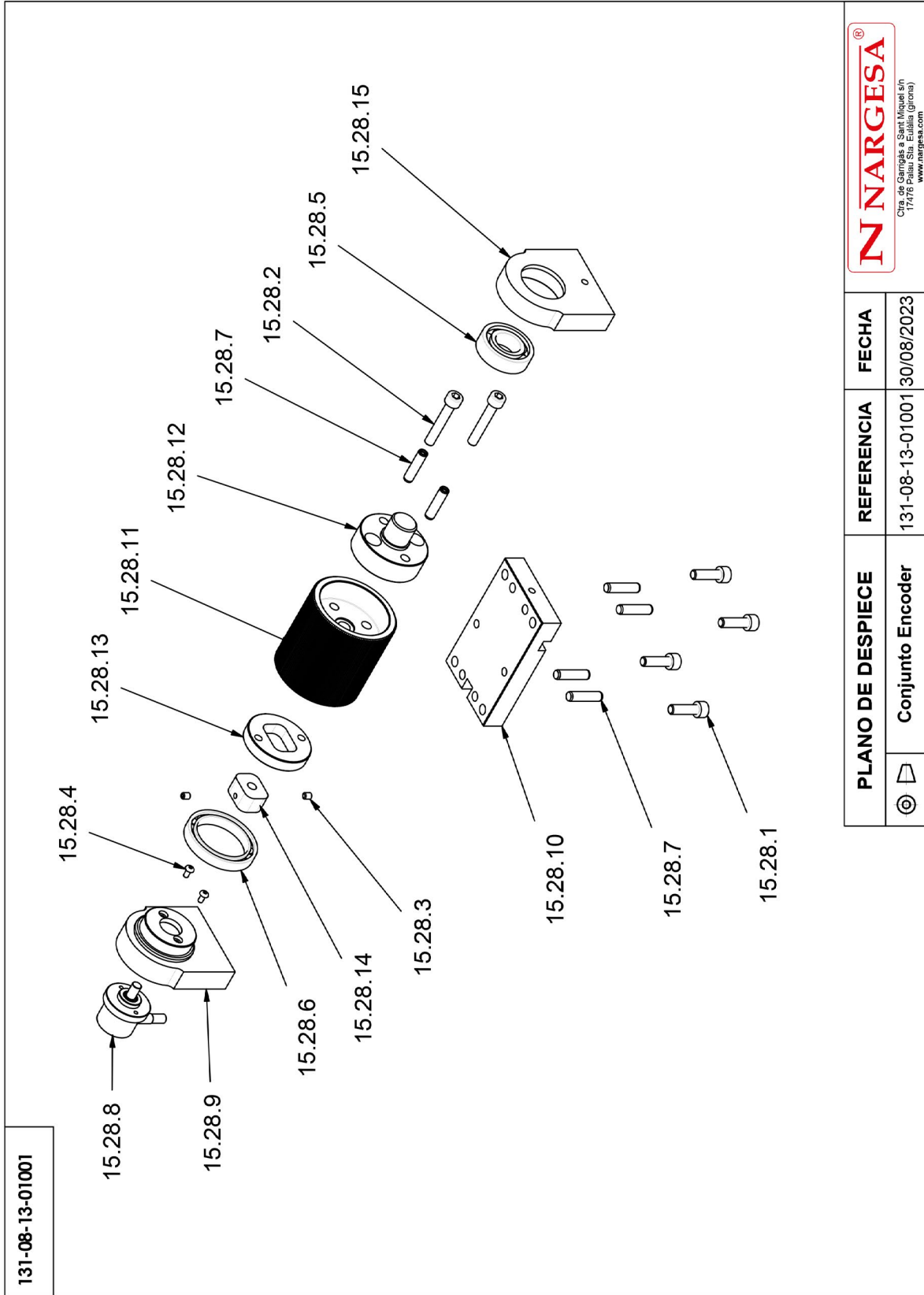

PLANO DE DESPIECE		REFERENCIA	FECHA
	Conjunto Encoder	131-08-13-01001	30/08/2023

**NARGESA**<sup>®</sup>

Ctra. de Garrigás e Sant Miquel s/n  
17476 Pallau Sta. Eulàlia (Girona)  
www.nargesa.com

Este plano es propiedad de Prada Nargesa S.L. No podrá ser reproducido, comunicado a terceros o utilizado para otro fin que no sea el acordado sin su permiso escrito.

Elemento	Miniatura	Nº de pieza	Descripción	CTDAD
15.28.1		020-D912-M6X20	Tornillo Allen DIN912 M6X20	4
15.28.2		020-D912-M6X35	Tornillo Allen DIN912 M6X35	2
15.28.3		020-D913-M4X5	ESPARRAGO ALLEN DIN 913 M4X5	2
15.28.4		020-I7380-M3X6	TORNILLO ISO 7380 M3X6	2
15.28.5		030-CJ-00037	Rodamiento DIN 625 SKF 6003-2RSH	1
15.28.6		030-CJ-00042	Rodamiento de Bolas 61807 D47XD35X7	1
15.28.7		030-D7979D-00009	Pasador Cilindrico Con Rosca Int. DIN7979/D D6X24	6
15.28.8		050-ENC-00012	Encoder Incremental Hohner 27-2222-4096	1
15.28.9		125-08-13-01000	Soporte Encoder	1
15.28.10		125-08-13-01001	Base Rodillo Cuentavueeltas	1
15.28.11		125-08-13-01002	Rodillo Grafilado	1
15.28.12		125-08-13-01003	Eje Rodillo Grafilado/ Encoder	1
15.28.13		125-08-13-01004	Eje Rodillo Grafilado	1
15.28.14		125-08-13-01005	Tuerca Arrastre Eje Encoder	1
15.28.15		125-08-13-01006	Soporte Encoder	1

# OUR RANGE OF MACHINERY



IRON WORKERS



NON-MANDREL PIPE BENDERS



SECTION BENDING MACHINES



CNC PIPE BENDERS



HORIZONTAL PRESS BRAKES



TWISTING/SCROLL BENDING MACHINES



HYDRAULIC PRESS BRAKES



HYDRAULIC SHEAR MACHINES



GAS FORGES



IRON EMBOSHING MACHINES



END WROUGHT IRON MACHINES



BROACHING MACHINES



POWER HAMMERS



BLACKSMITH FORGING PRESS