



# INSTRUCTIONS BOOK

---

## LASER WELDING EQUIPMENT

### MS20

NS: 2025-101



---

PRADA NARGESA, S.L.

Ctra. de Garrigàs a Sant Miquel s/n · 17476 Palau de Santa Eulàlia (Girona) SPAIN

Tel. +34 972568085 · nargesa@nargesa.com · www.nargesa.com

# NARGESA CLIENTS

Prada Nargesa has more than 12.200 customers around the world. Some of our clients, those who offer service to third parties with the Nargesa machinery in their workshops, have been pleased to be part of this network that aims to connect them with possible future clients. In this way, all those people or companies that have a need for any part or tool that can be manufactured by using the Nargesa range of machinery, will be able to find a solution in their area to be able to satisfy their production requirements by hiring their services.



**We have more than 12.200 customers in 150 different countries around the world**

Discover its location on the interactive map on our website!

## DO YOU WANT TO PARTICIPATE?

Send an email to [nargesa@nargesa.com](mailto:nargesa@nargesa.com), include the following information and we will add you to this list.

We want to encourage all those who haven't participated yet in this great commercial network!

1. Company name
2. CIF/Tax Code
3. City
4. Country
5. Machine or machines

# PRADA NARGESA

---

Prada Nargesa S.L. is a family business founded in 1970 located near Barcelona, Spain, with more than 50 years of experience in the sector of manufacturing of industrial machinery, and more than 10.000m<sup>2</sup> of facilities. Nargesa is a symbol of quality, reliability, warranty and innovation.

Our whole range of machines and accessories is manufactured entirely in Nargesa. We have a constant stock of 400 machines, and we have more than 21.300 machines sold all over the world.



## OUR RANGE OF MACHINERY

Ironworker Machines  
Ring Roller Bender and Pipe Bender  
Non-mandrel Tube and Pipe Bender  
Twisting / Scroll Bending Machines  
Horizontal Press Brakes  
End Wrought Iron Machines  
Gas Forges

Iron Embossing Machines  
Hydraulic Shear Machines  
Hydraulic Press Brakes  
Presses for Locks  
Broaching Machines  
Power Hammers

# CERTIFICATES

---

Prada Nargesa has several certifications that backup both, the design and manufacturing processes, as well as the journey through exporting our products around the world and the quality of the manufacturing components we use for our machines. These facts turn into real advantages for our customers:



## AUTHORIZED EXPORTER

- Faster customs procedures
- Reduction of tariff documentation
- Tariff preferences according to geographical location



## INNOVATIVE SME

- Development in innovation, design and manufacturing technologies
- Certification and audit of efficiency in product and service
- Ability to foresee customer needs



## R+D+I MANAGEMENT

- Manufacturing based on the R+D+I process
- Technological surveillance system

# SUCCESS STORIES

---

At Prada Nargesa we believe that the testimony of our clients is our best guarantee, and that is why we like to expose some of the success stories that we have witnessed around the world:



Discover its location on the interactive map on our website!

## DO YOU WANT TO PARTICIPATE?

Send an email to [nargesa@nargesa.com](mailto:nargesa@nargesa.com) including the following information and we will add you to our website:

- Company name
- Testimonial name
- Post in the Company
- Country
- Descriptive text
- Photography with the machine

## CONTENTS

<b>1. EQUIPMENT FEATURES.....</b>	<b>10</b>
1.1. General dimensions .....	10
1.2. Description of the equipment.....	10
1.3. Identification of components.....	12
1.4. Technical description .....	16
1.5. Control panel.....	19
1.6. Locking and removing the feeder.....	19
1.7. Transportation.....	20
<b>2. INFORMATION ABOUT THE WORK ENVIRONMENT .....</b>	<b>21</b>
2.1. Installation area .....	21
2.2. Environmental conditions.....	23
<b>3. FIRST STEPS .....</b>	<b>24</b>
3.1. Unloading equipment from the pallet and using the ramp.....	24
3.2. Installation and gas connection .....	26
3.3. Connection and start-up .....	28
3.4. Choosing the operating mode.....	29
3.5. Installing the safety clamp.....	30
<b>4. NOZZLE SELECTION AND ADJUSTMENT .....</b>	<b>31</b>
4.1. Type of joint or weld geometry.....	31
<b>5. FORESEEABLE MISUSES.....</b>	<b>34</b>
5.1. Technically incorrect uses .....	34
5.2. Recreational or inappropriate uses.....	34
5.3. Unauthorized tampering .....	34
5.4. Legal warning .....	34
5.5. Ban on operating with deteriorated safety mechanisms .....	35
5.6. Checking the emergency shutdown and safety components .....	35
<b>6. RISKS WITH THE EQUIPMENT .....</b>	<b>37</b>
6.1. List of residual risks with the equipment .....	37
6.2. List of general risks with the equipment .....	37
<b>7. REPLACING PROTECTIVE AND FOCUSING LENSES.....</b>	<b>38</b>
7.1. Tools and materials needed .....	38
7.2. Procedure for replacing the protective lens.....	38
7.3. Procedure for replacing the focusing lens .....	43
<b>8. REPLACING THE WIRE .....</b>	<b>48</b>
<b>9. INSTRUCTIONS FOR USE .....</b>	<b>58</b>
9.1. Start-up.....	58
9.2. Cut mode .....	59
9.2.1. Troubleshooting.....	63
9.3. Weld mode .....	64
9.3.1. Load welding wire.....	72
9.4. Clean mode .....	74
9.5. Saving programs .....	79

<b>10. SETTINGS</b> .....	81
10.1. Visual check of laser centering.....	81
10.2. Laser centering.....	81
10.3. Focal point adjustment.....	86
<b>11. ERROR MANAGEMENT</b> .....	<b>90</b>
<b>12. PROBLEMS WITH THE WELDING PROCESS</b> .....	<b>91</b>
12.1. Material projections.....	91
12.2. Side bite.....	91
12.3. Bead collapse (subsidence).....	91
12.4. Porosity.....	91
12.5. Cracks (hot / cold).....	92
12.6. Lack of fusion / lack of penetration.....	92
12.7. Part deformation.....	92
12.8. Material considerations.....	92
12.8.1. Carbon steel.....	92
12.8.2. Stainless steel.....	93
12.8.3. Aluminum alloys.....	93
<b>13. MAINTENANCE</b> .....	<b>94</b>
13.1. Preventive maintenance.....	94
13.2. Predictive maintenance.....	95
13.3. Corrective maintenance.....	96
<b>14. ACCESSORIES AND CONSUMABLES</b> .....	<b>97</b>
14.1. Included accessories.....	97
14.2. Optional accessories and consumables.....	102

## 1. EQUIPMENT FEATURES

### 1.1. General dimensions

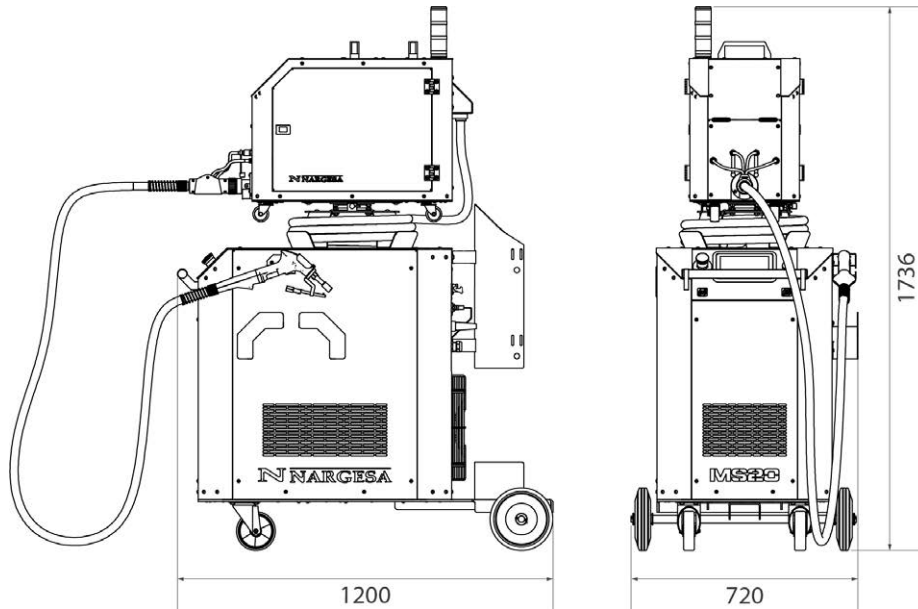

### 1.2. Description of the equipment

**The MS20 is a 2000 W fiber optic laser welding equipment, specifically developed for welding sheets of different materials, thicknesses and positions.** It is designed to offer an efficient, accurate and versatile solution in manufacturing, maintenance and metallic structure processes, both in industrial environments and specialized workshops.

With a modular design, the MS20 can also perform weld bead cleaning with a simple adjustment using the touchscreen and without needing to change any accessories. Plus, it includes a feature to cut carbon steel up to 2 mm, which considerably expands its use.

One of the outstanding features of the equipment is that the feeder (wire feeder) is removable, which can increase the reach of the head hose by up to 3.5 additional meters, facilitating access to hard-to-reach areas or large parts.

This system has been designed to optimize workflows, minimize setup times and provide high quality welds with a professional finish.

Below is the MS20 equipment nameplate, which shows the main identification details of the equipment (model, serial number, power supply voltages, year of manufacture, etc.). Also included is the FDA information label, which indicates that the equipment complies with FDA performance standards for laser products, in accordance with IEC 60825-1 Ed.3 and as described in Laser Notice No. 56, dated May 8, 2019.

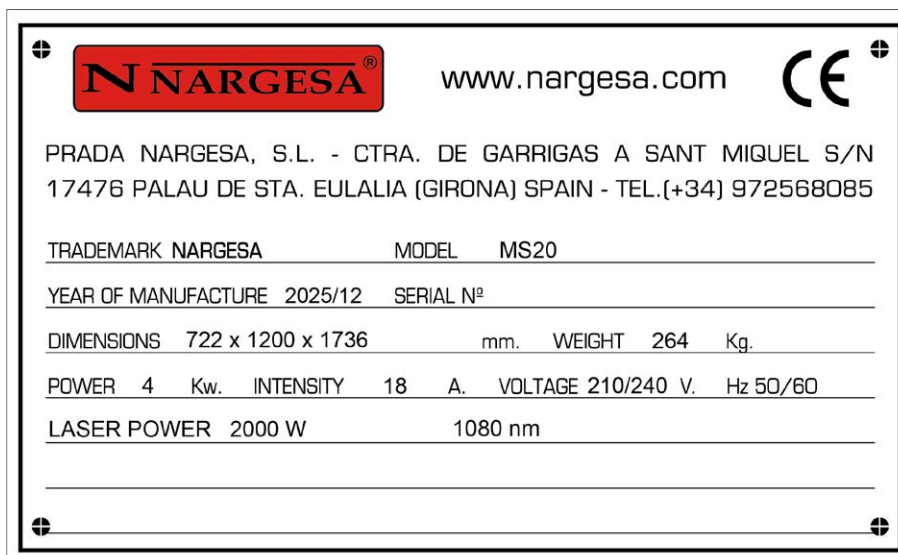

**Complies with FDA performance standards except for conformance with IEC 60825-1 Ed.3., as described in Laser Notice No. 56, dated May 8, 2019.**

**1.3. Identification of components**

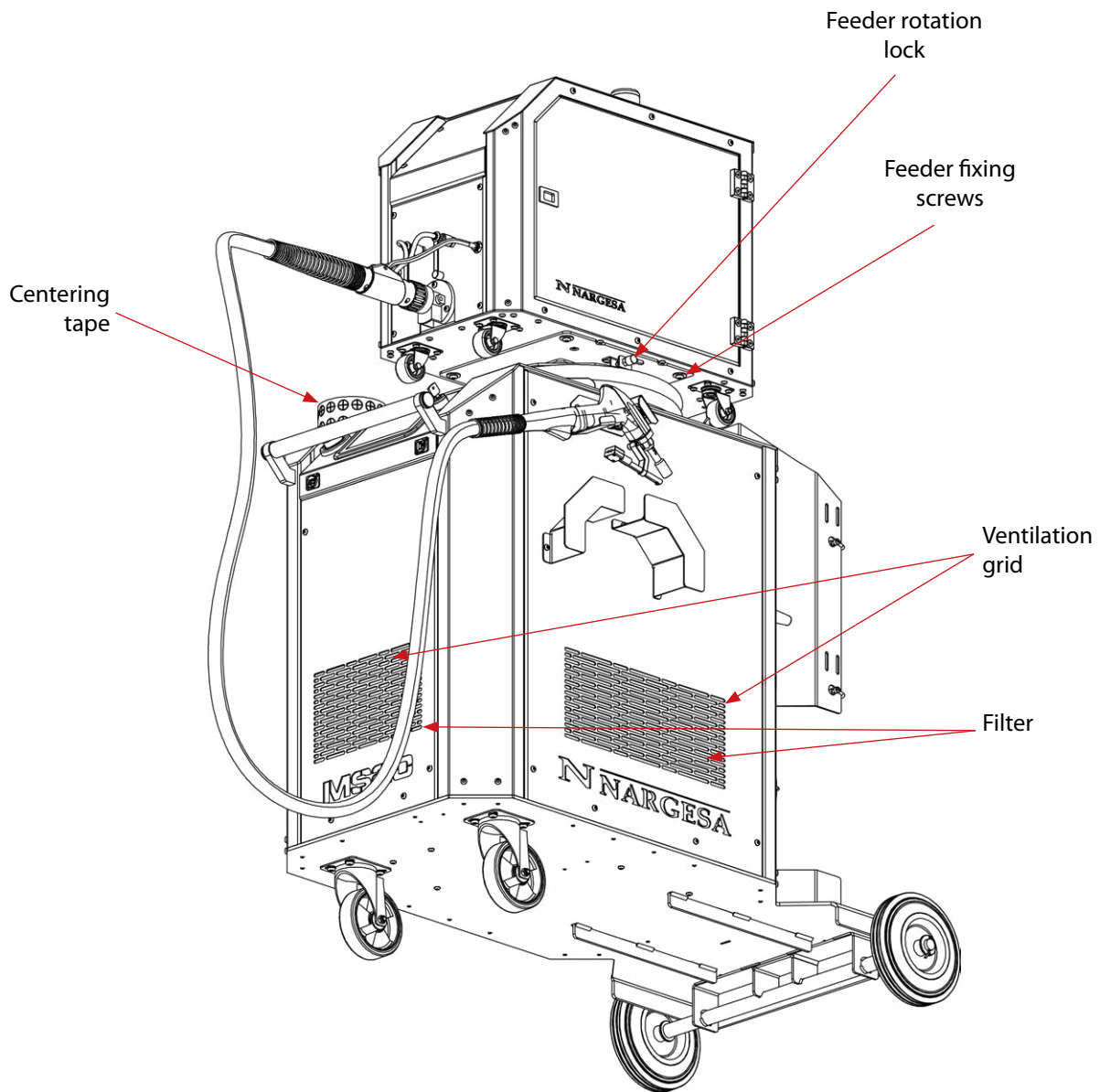

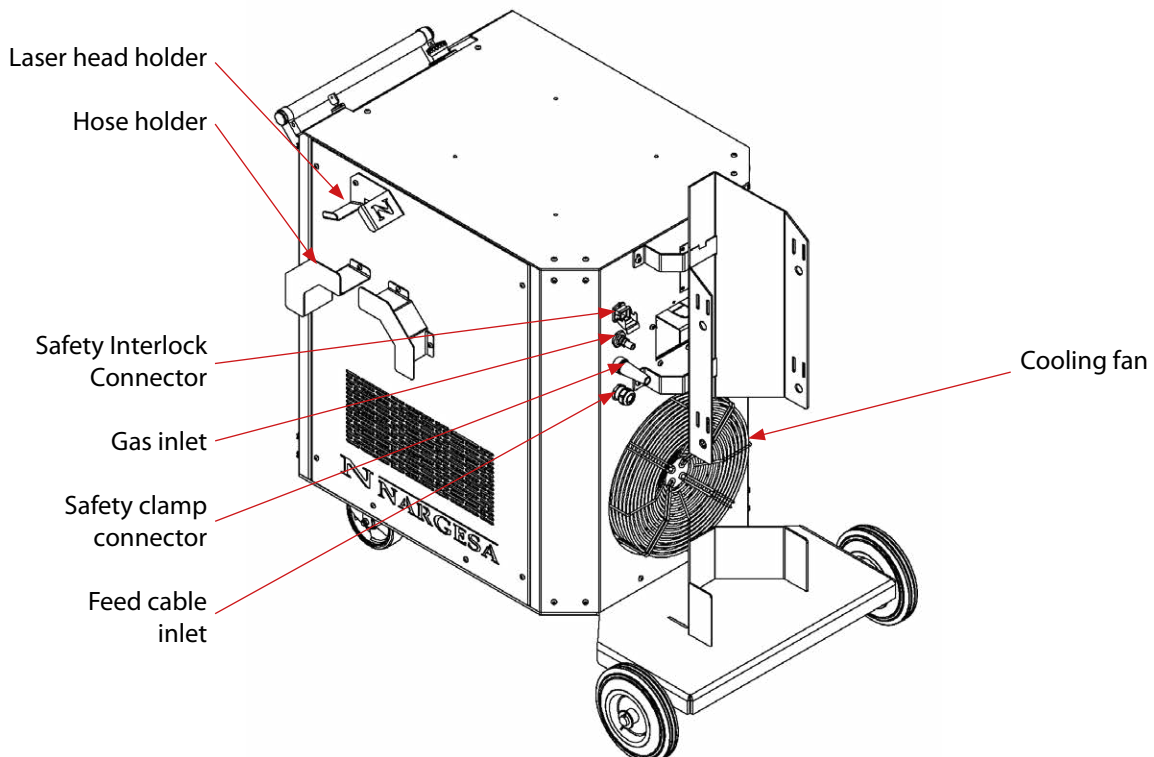
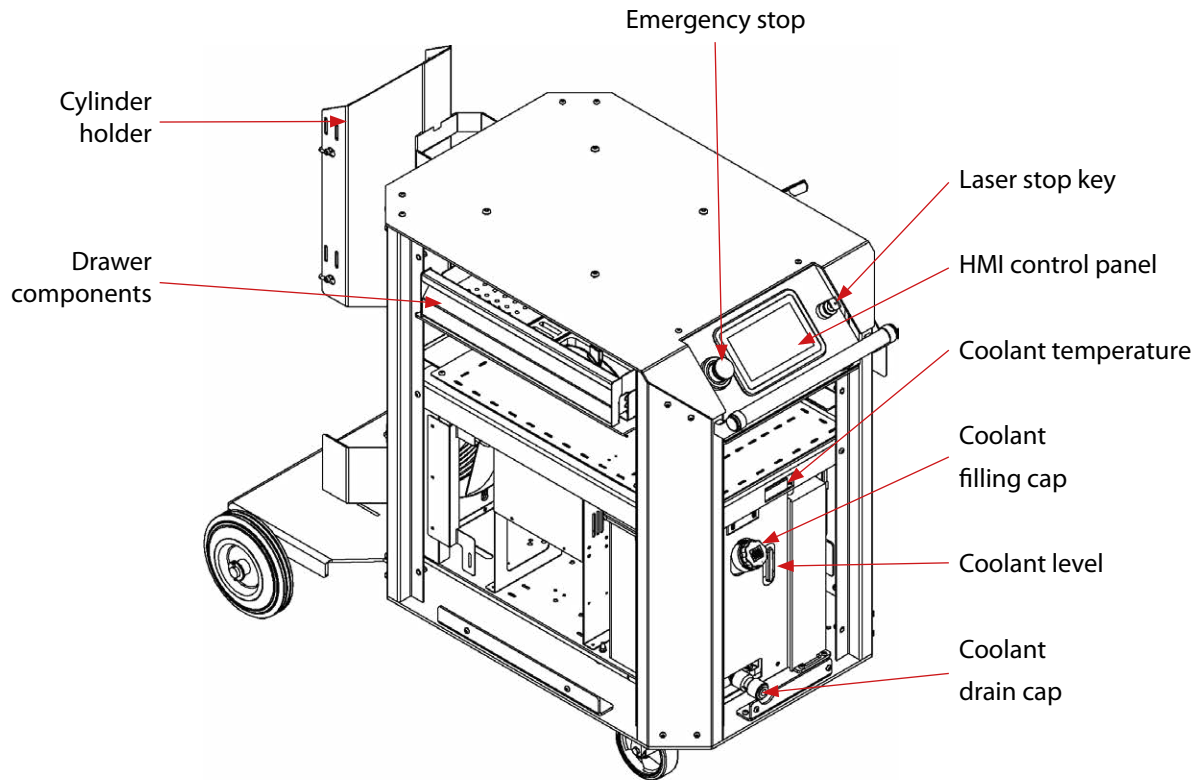

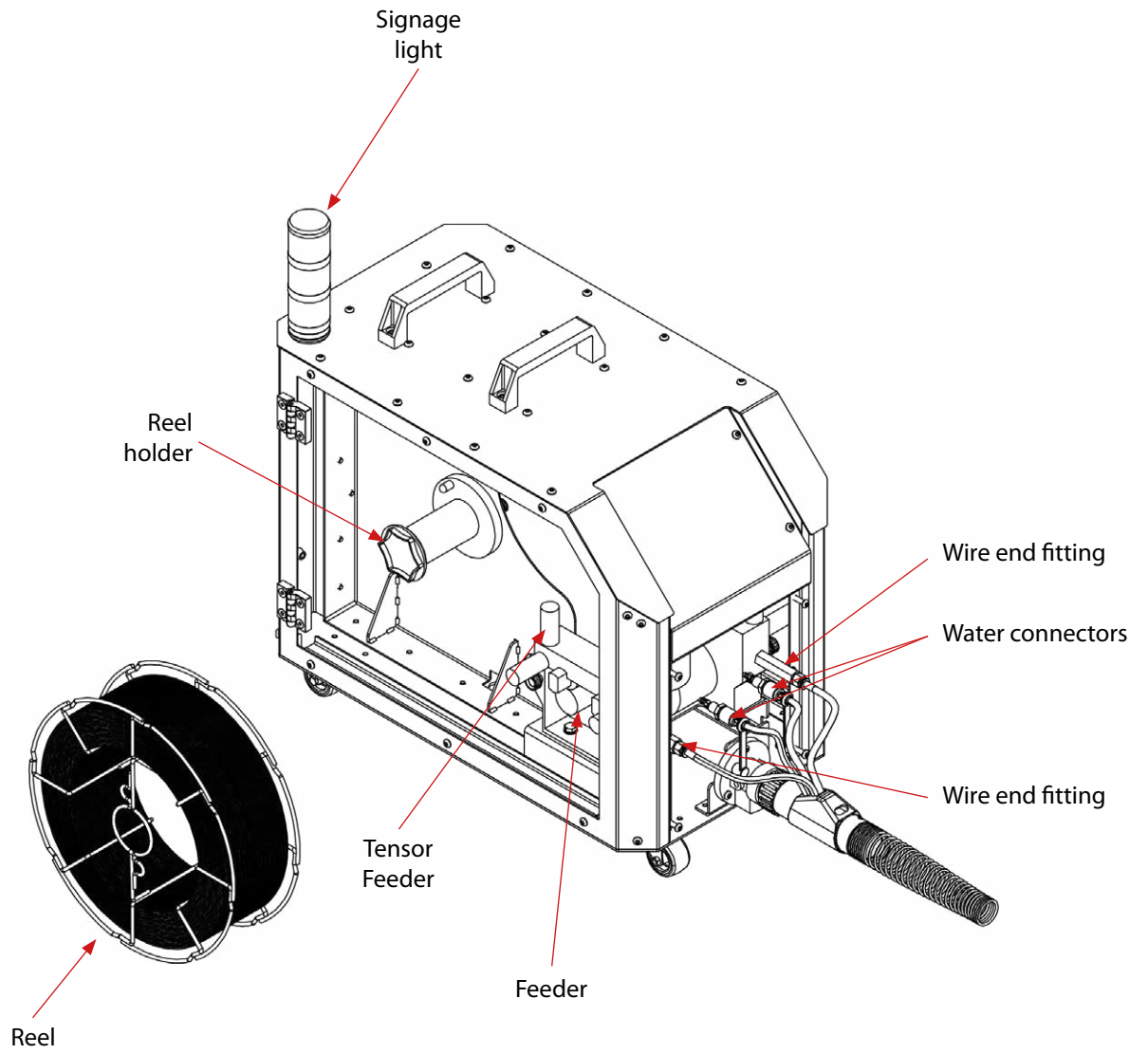

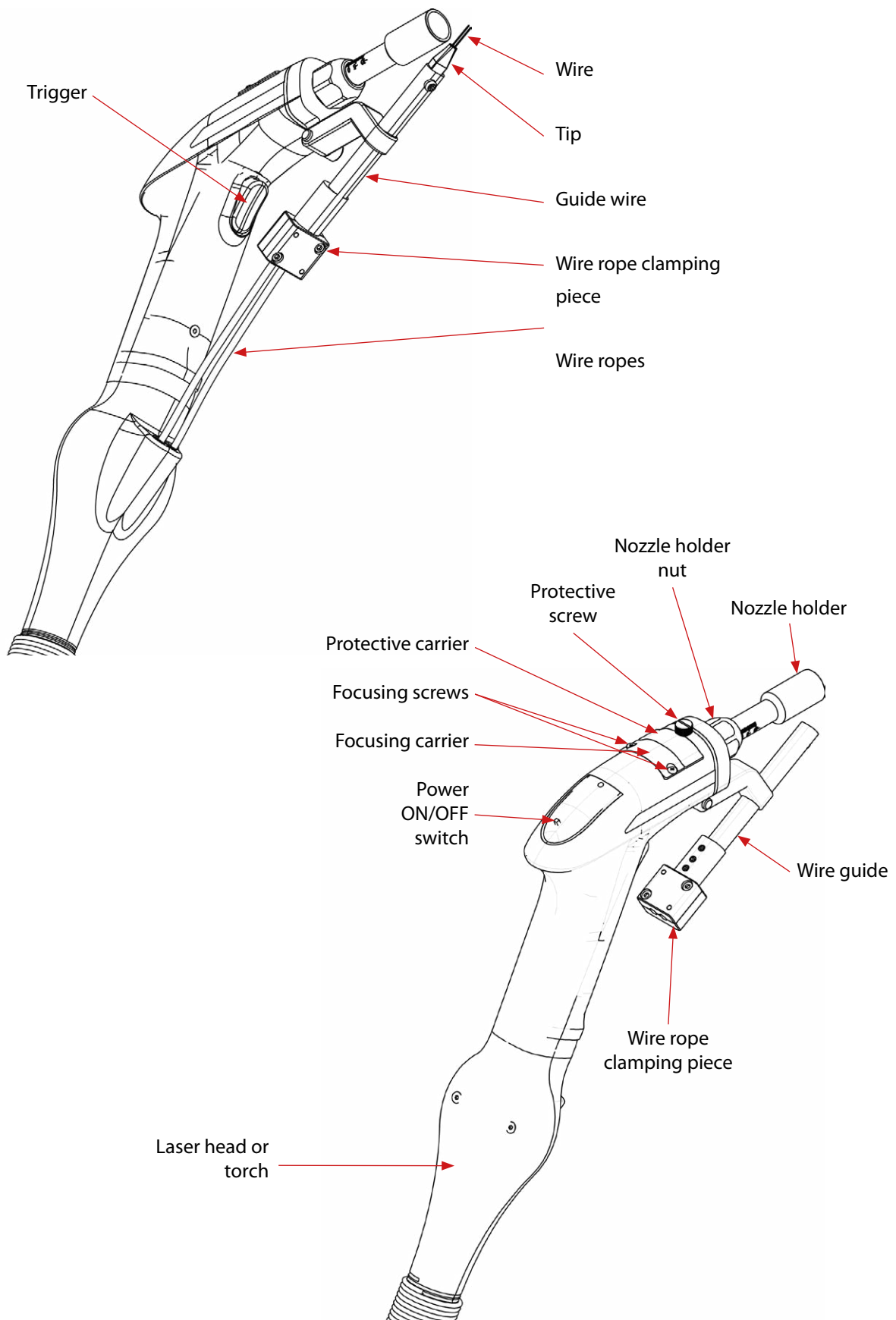

## 1.4. Technical description

**Power:** 2000 W / 2 kW

**Voltage:** 220 / 240 V Single-phase.

**Frequency:** 50 / 60 Hz

**Fusion penetration depth:** 6 mm

**Cutting capacity:** 4 mm

**Wavelength:** 1080 nm

**Fiber hose length:** 10 meters

**Fiber diameter:** 25 µm

**Laser guide:** 630-650 nm / 0.5-1 mW

**Maximum laser beam aperture:** 5 mm / 0.2" Single input - 8 mm / 0.31" double input

**Power consumption:** 4 kW

**Maximum amperage:** 16 A

**Weight:** 264 kg

**Dimensions:** 722 x 1200 x 1736 mm

**Cooling method:** distilled water

**Cooling reservoir capacity:** 10 liters

Very intuitive and easy to use CNC control panel ESA S820 7" touchscreen.

Alarm Diagnostics.

4.0 Technology

Control in mm and inches

Temperature control in degrees Celsius and Fahrenheit

Resonator status control via Bluetooth.

**Maximum wire capacity:** two 2 mm / 0.079" reels

**Reel capacity:** 2 units of 15 kg Ø300

Built-in interior LED light.

Possibility of working with two reels of the same or different wires.

**Number of drag rakes:** 2 units.

Number of motorized drag rollers: 8 units.

**Cleaning range:** 0 to 14mm / 0" to 0,55"

**Maximum operating slope:** Flat surface

**Center of gravity:** 648 mm from the ground, centered on the other axes

The MS20 is a multi-function industrial laser welding equipment for high precision welding, weld seam cleaning and fine cutting of various materials. Designed to maximize efficiency, it offers a clean, safe and quality finish in demanding manufacturing processes.

### Features included:

- High precision laser welding for multiple materials and thicknesses.
- Weld bead cleaning can be activated from the display without changing accessories.
- Cutting for black ASTM36 up to 2 mm thick.

The MS20 laser welding unit is comprised of two main modules, each with specific features:

**Lower unit:**

- **Chiller (built-in refrigerator):** Water cooling system responsible for maintaining the optimum temperature of all critical equipment components, ensuring safe and continuous operation.
- **Laser source (resonator):** Fiber optic laser beam generator with a power of 2000 W, providing deep, stable and high precision welding.
- **Storage drawer:** Physical space to store tools, nozzles, glasses, spare parts and other accessories necessary for the operation.

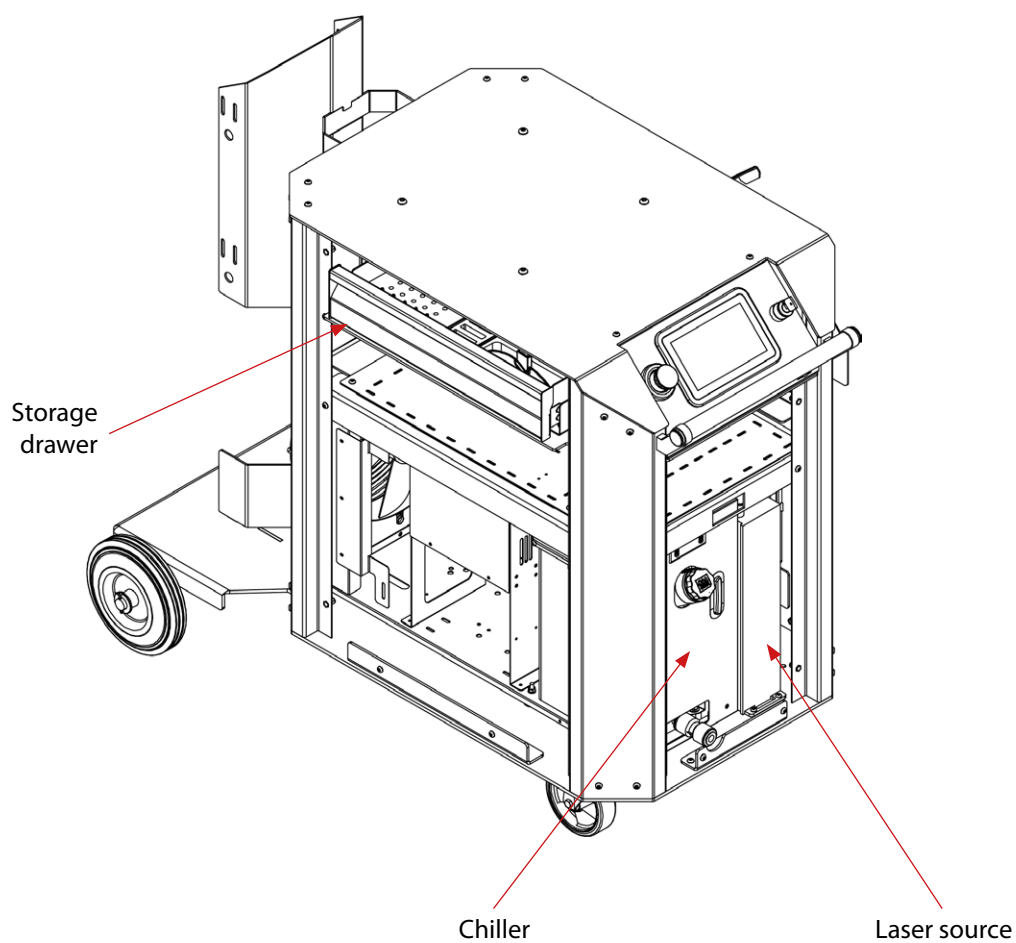

**Upper unit (wire feeder):**

- **Wire feed system** with two double drive motors, which ensure a stable and continuous feeding of the filler wire.
- **Two reel holders** to use different types of wire, to have a spare ready for replacements or to make cords with different filler thicknesses.
- **Built-in LED light** to illuminate the inner area and make it easier to switch the filler wire.
- **Header hose outlet** with the fiber cable, the filler wires, the shielding gas and the cooling water.
- **Removable feeder**, which can extend the operating range by up to 3.5 additional meters.

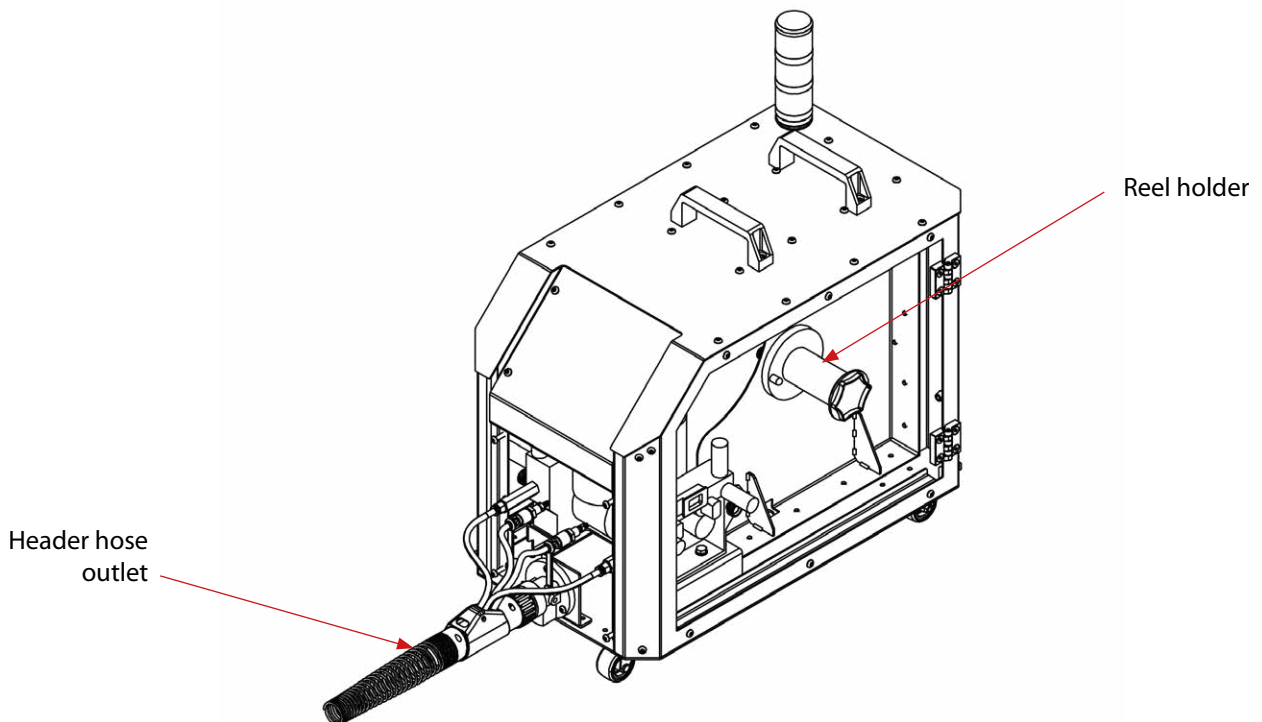
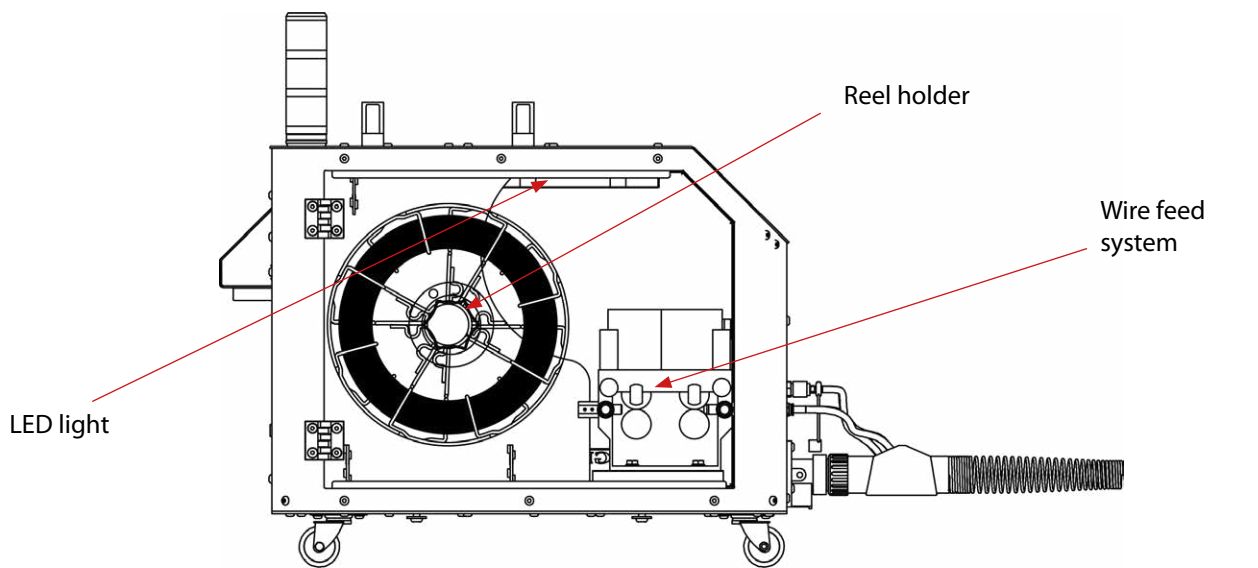

### 1.5. Control panel



### 1.6. Locking and removing the feeder

The feeder can be locked to facilitate reel positioning and feeder component handling.

The feeder can be locked and unlocked by aligning the locking pin and the plate indicated in the following image and turning the locking pin 180°.

The feeder can be removed by loosening the four lower screws indicated in the picture and securing the nuts located inside the feeder.

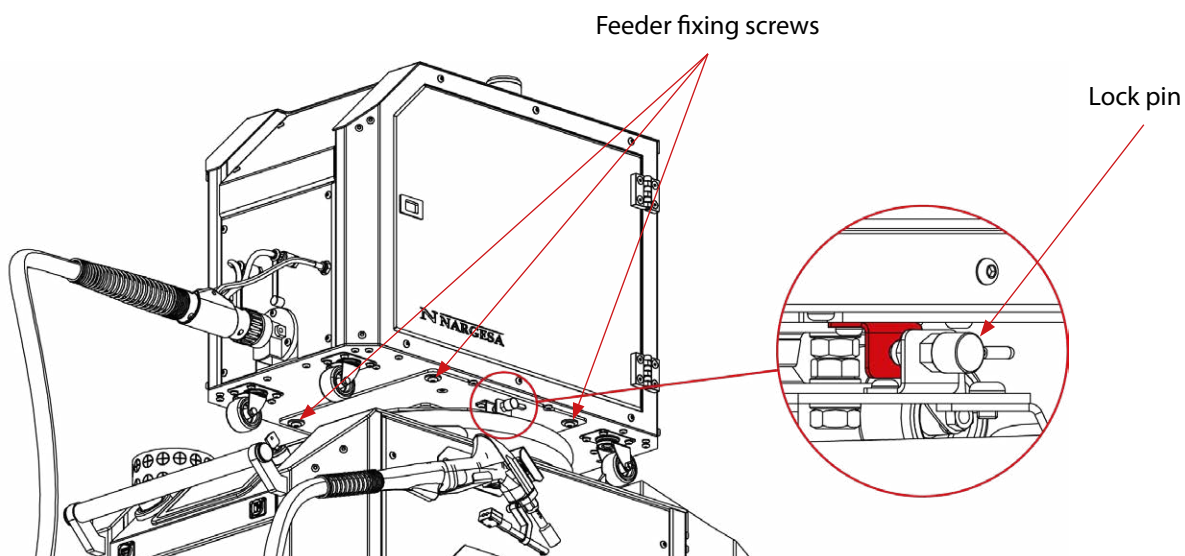

### 1.7. Transportation

The MS20 can be moved along the bottom at the base of the welder with a pallet truck or forklift as shown in the illustration.

Never raise the equipment more than 300 mm above the surface, nor exceed the width of the wheels with the blades. They must always remain inside the wheels without resting on them.

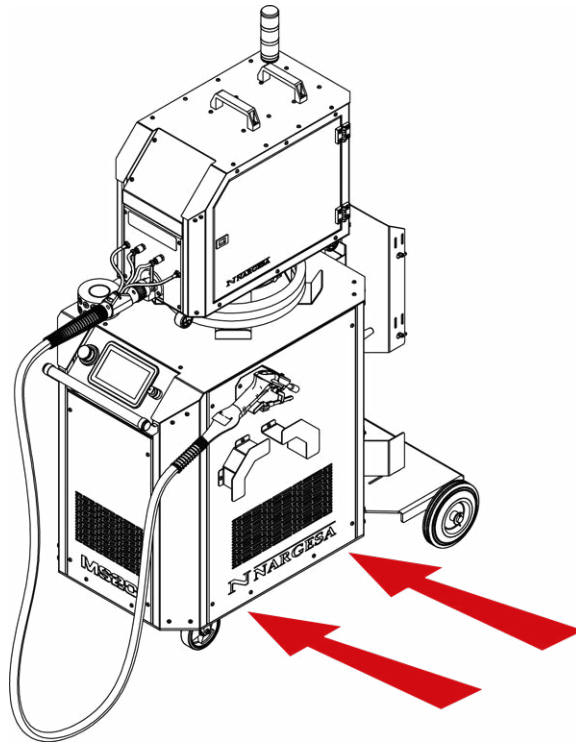

## 2. INFORMATION ABOUT THE WORK ENVIRONMENT

### 2.1. Installation area

Cabinet pursuant to ISO/IEC 60825-1 and ISO/IEC 60825-4 (2000 W, class 4 laser)

For 2000 W, class 4 laser welding equipment, installing and operating the equipment inside a cabinet/enclosure that meets the requirements of ISO/IEC 60825-1 and ISO/IEC 60825-4 is mandatory.

#### Important considerations

Maximum Permissible Exposure (MPE) is the maximum level of laser radiation to which a person may be exposed, under normal operating conditions, without risk of adverse biological effects. The MPE associated with the laser integrated into the MS20 model is 50 W/m<sup>2</sup>.

Nominal Ocular Hazard Distance (NOHD) is the distance, measured from the laser exit aperture, beyond which the beam irradiance or radiant exposure remains below the corneal Maximum Permissible Exposure (MPE). The NOHD associated with the laser integrated into the MS20 model is greater than 280 m.

#### Interpretation

The nominal distance of 280 m represents the maximum distance at which an ocular hazard may exist. This value is determined assuming direct exposure; in other words, if an operator intentionally points the device directly at a person, there is a potential risk of eye injury up to this distance.)

#### **Hazards Associated with Laser Radiation (Direct or Reflected):**

In industrial laser applications, particularly when using manual laser welding equipment, it shall be taken into account that high-intensity and hazardous laser radiation may be present behind the workpiece due to direct beam propagation. Additionally, laser radiation may be reflected in any direction away from the operator's working area when interacting with flat surfaces, or even reflected back toward the operator when interacting with curved surfaces, edges, corners, or inclined parts

#### **The cabinet must:**

- Confine the beam and its reflections (direct and diffuse) during operation, avoiding personnel exposure.
- Include safety interlocks on all doors/covers so that they inhibit emission upon opening (fail-safe design).
- Use materials and protective screens certified for the 1080 nm wavelength and the equipment's power output. If there are observation windows, they must have the appropriate protection rating/OD and clear, visible marking.
- Have emission indicators (before and in operation), a key switch and, when applicable, a shutter/attenuator to block the beam.
- Have external signage ("LASER IN OPERATION", class,  $\lambda$ , PPE required) and access control for authorized personnel.
- Maintain non-reflective interiors (matte finishes) and smoke management through localized extraction.
- Include accessible and verified emergency stops.
- Be subject to initial verification and periodic reviews (functioning interlocks, conditions of screens/windows, signage), with documented records.

The presence of flammable materials in the entire cabinet is strictly forbidden (please remember that any deflected beam or specular reflections can ignite materials such as plastic, paper, wood, etc.).



**Installation requirement: The MS20 must not be operated outside the cabinet** pursuant to ISO/IEC 60825-1 and ISO/IEC 60825-4. Any work with the open enclosure shall be carried out using specific procedures with additional controls and authorization.

Operation of the MS20 (2000 W, class 4) **outside an enclosure/cabinet compliant with ISO/IEC 60825-1 and ISO/IEC 60825-4 is expressly forbidden.** Prada Nargesa, S.L. is not liable under any circumstance for any personal injury, property damage or loss, direct or indirect, arising from the misuse, modification or maintenance of the equipment without the cabinet, interlocks and shielding properly installed, verified and in service.

**In the event of a fire, use a CO2 extinguisher.**

### **Safety Interlock Connector**

The MS20 is equipped with a Safety Interlock Connector for integration with external safety devices, such as a welding enclosure.

The interlock connector (or safety interlock connector) is a safety device designed to enable or inhibit the operation of the MS20 depending on the status of an external safety element.

### **Purpose**

- Prevent laser emission when required safety conditions are not met.
- Integrate the laser into an external safety system, such as:
  - o safety doors,
  - o light curtains,
  - o enclosure interlocks,
  - o emergency stop devices,
  - o access control systems.

### **Operation on the MS20**

- The interlock connector is part of a safety circuit (dry contacts). The electrical diagram can be found in the Technical Annex.
- When the circuit is closed, the equipment is permitted to operate.
- When the circuit is opened (for example, when a safety door is opened), the machine's laser is disabled and transitions to a safe state.

### **Preliminary Considerations and Connections**

First, it must be noted that these are safety-related connections; therefore, only properly trained and authorized personnel are permitted to perform these operations.

As shown in the MS20 electrical diagram included in the Technical Annex of this instructions book, only two safety contacts are required to connect to a safety enclosure or external safety device. These contacts are potential-free (dry contacts).

The connection is made by wiring the four conductors to the corresponding connector so that, if the machine is operating and the external safety chain is opened, the machine stops automatically and cannot be restarted until the contacts are closed again by the external safety chain.

In addition, once the safety chain has been restored, the MS20 requires a manual reset before it can be placed back into service.

### **2.2. Environmental conditions**

- **Operating temperature and humidity:** Keep the equipment between 0° and 30°C and between 30 and 80% RH, avoiding sudden changes to protect the lenses and the source.

If the system temperature is below 25°C, wait until the equipment has reached the required minimum temperature before resetting. Once the system has warmed up sufficiently, the blue button will enable the reset option. The temperature can be monitored at all times on the control screen indicated to determine when the equipment is ready for operation.

- **Ambient cleanliness:** Keep the area free of dust, oils and aerosols, and implement a general air-cleaning and filtration plan.

- **Vibrations:** Keep the MS20 away from presses, hammers or other machines that create vibrations.

- **Noise and comfort:** Ensure acceptable noise levels and adequate general ventilation for personnel.

- Do not use on the same table as other high frequency equipment such as Mig/Tig welders.

### 3. FIRST STEPS

#### 3.1. Unloading equipment from the pallet and using the ramp

For correct initial handling of the MS20 laser welding equipment and to avoid personal injury or material damage, the pallet must be unloaded strictly following the instructions as described below.

##### Safety warnings

- This operation must always be performed by a minimum of two people.
- Wearing safety footwear and protective gloves is mandatory.
- Make sure the work area is clean, dry, well illuminated and free of obstacles.
- Check that the pallet is on a flat and stable surface.
- Standing in front of the MS20 in the downward direction of the ramp, passing under the equipment or inserting hands/feet under the base during the movement is absolutely prohibited.
- Do not push the MS20 roughly or attempt to move it by pulling on the head hose, cables or service hoses.

##### 1. Preparing and removing the ramp

Carefully open the transport box.

Locate the supplied ramp inside the enclosure, usually on the front of the unit.

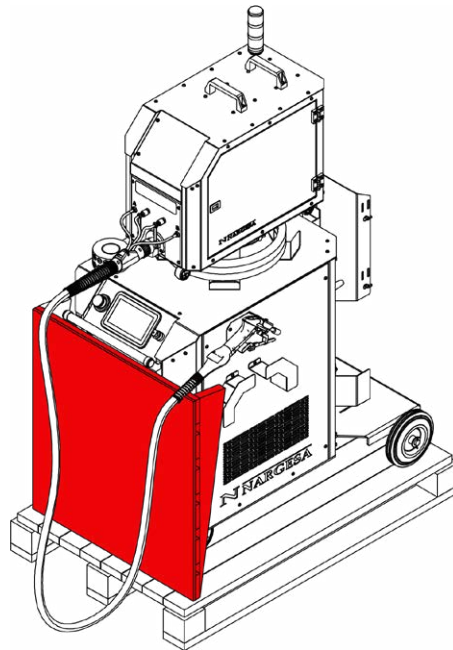

Place the ramp in a horizontal position on the ground, away from the passage area, while the equipment is being prepared.

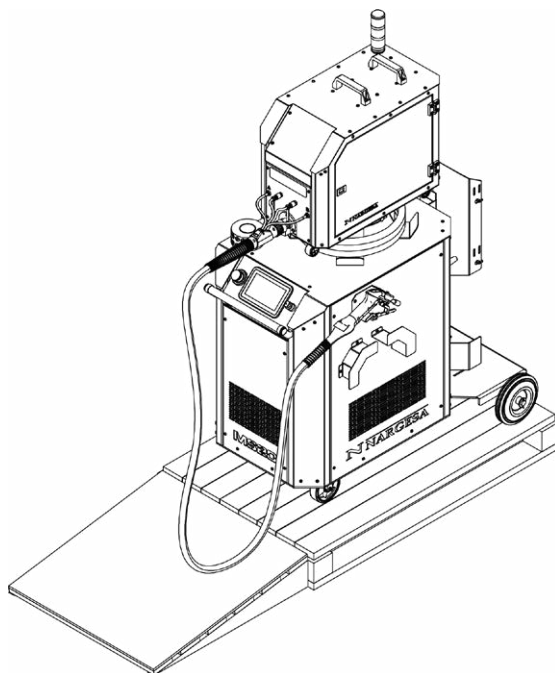

## **2. Preparing the equipment on the pallet**

Visually check the condition of the equipment and the pallet, verifying that there is no visible damage or deformation.

Identify the straps, bands, screws or plugs that secure the equipment to the pallet.

Do not remove all the fasteners yet: leave at least one fastening point until the ramp is in place to avoid unintentional displacement.

## **3. Unloading the MS20 along the ramp**

Place the ramp at the front of the equipment as close as possible to the pallet on the side where the unloading is to be performed.

Check that the wheels of the equipment are free and that there are no packaging elements (wood, wedges, chocks) that could block the movement.

Operator positions:

- One operator shall stand at the back, behind the MS20, controlling the feed and applying the main effort.
- A second operator shall stand on the side, helping to guide and stabilize the equipment during the descent.

Start the descent by gently pushing the equipment down the ramp, avoiding jerks or sudden changes in direction.

You must keep the MS20 centered on the ramp during the entire descent.

If at any time instability, abnormal noise or risk of rollover is perceived:

- Immediately stop the maneuver.
- Return the laser welder to a safe position and recheck the ramp and environment before continuing.

Once the MS20 has been unloaded from the pallet and is correctly positioned on the floor, you can continue with the assembly and gas connection.

### 3.2. Installation and gas connection

For correct use of the MS20 laser welding equipment, the following steps must be followed:

**\* Materials required for installation, supplied with the equipment:**

- 1.5 meters of pneumatic tubing with a minimum pressure rating of 10 bar.
- 2 clamps suitable for the pneumatic tubing.
- 1 argon and nitrogen pressure regulator with a range of 0-10 bar.

#### 1. Shielding gas assembly.

First of all, assemble the gas cylinder in the correct position on the equipment and secure it with the chains supplied.

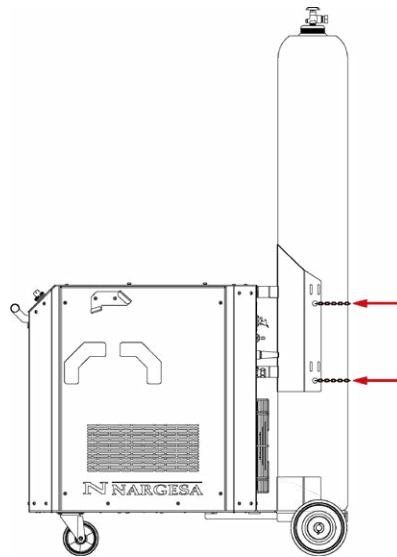

#### 2. Installing the pressure regulator

The equipment is supplied with a regulator suitable for technical gases (argon, nitrogen, or gas mix), with a working range of 0-25 l/min. Install the regulator on the cylinder following the instructions for the component itself and ensuring correct assembly.

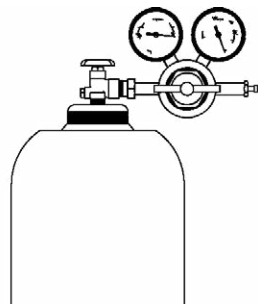

**3. Gas pipe connection.**

Connect the  $\text{Ø}12 \times 6$  mm pneumatic pipe from the regulator outlet to the gas inlet of the equipment. Before installation, check that the pipe is approved to operate at a maximum pressure of 10 bar, ensuring that it can correctly withstand the operating conditions of the system. It is essential to check that both ends are correctly inserted and secured with suitable clamps to prevent leaks.

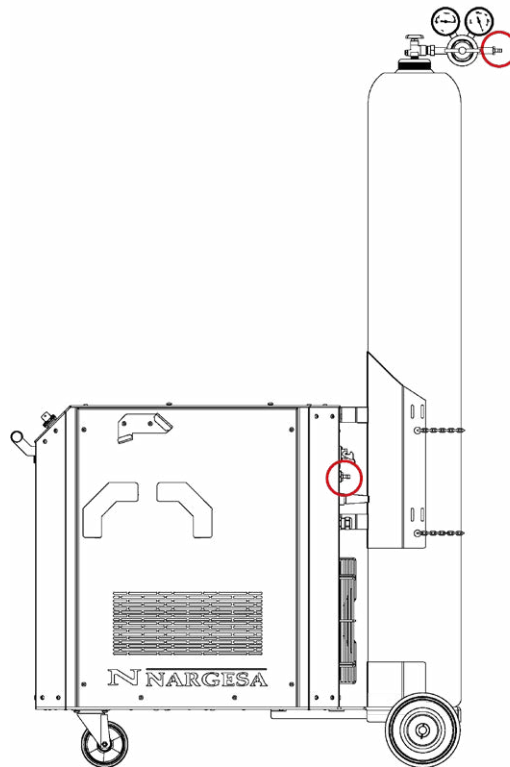
**4. Checking for leaks.**

Once the connection has been made, slowly open the cylinder valve and check that there are no leaks at the joints. If a loss of pressure is detected, check that the connections are tight and check the condition of the tube and joints.

### 3.3. Connection and start-up

Connect the main power socket and then turn on the main switch of the equipment.

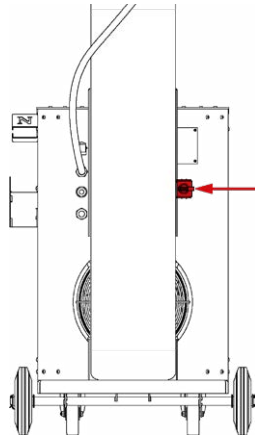

Once powered on, the touchscreen will automatically initialize and display the main mode selection menu.

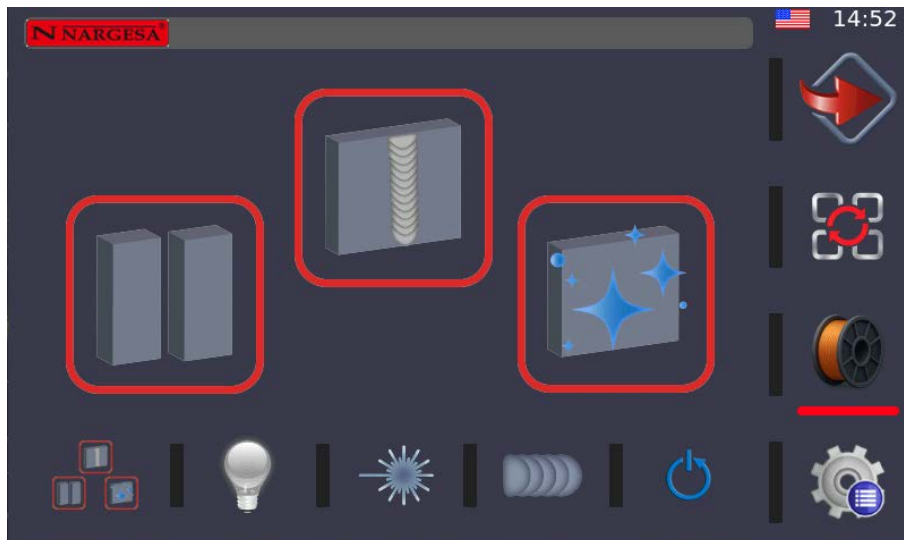

You must verify that the coolant level is correct.

Remove the front cover of the lower unit and check that the water level is in the green zone on the indicator. Otherwise, you must fill the tank until the level reaches this area.

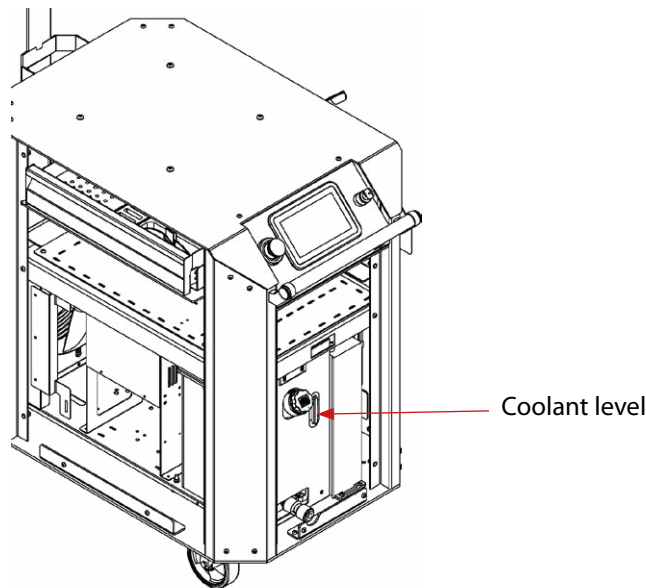

### 3.4. Choosing the operating mode

From the interface, you can select one of the three available operating modes:



#### **Weld mode**

When selecting the weld mode, you have two configuration options:

- **Using default parameters:** The equipment comes programmed with a number of preset configurations for different materials and thicknesses, allowing immediate operation without the need for manual adjustments.
- **Customized configuration:** Alternatively, it is possible to manually adjust key parameters (power, frequency, speed, etc.) depending on the job. These customized parameters can be saved in the system database for easier reuse in future processes.

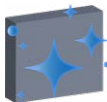

#### **Clean mode**

To activate the clean mode, simply select the thickness of the sheet metal to be treated. The system will automatically adjust the optimal settings to clean the weld bead.

If a more precise finish is required or adapted to a specific material or cleaning, you can manually adjust the power and beam opening, optimizing the cleaning process according to your needs.



#### **Cut mode**

The cut mode works much like the others. Select the material to be cut from the screen and the system will load the recommended power and speed parameters for that material.

For more demanding or specific cuts, you can manually modify parameters such as laser power or feed rate, allowing fine-tuning of the process.

### 3.5. Installing the safety clamp

The safety clamp is a critical component for the protection of the operator and the environment. Correct positioning thereof is mandatory before starting any work process.

This clamp must be firmly connected to the workpiece or work table, never to the torch. The system is designed so that the laser is only activated if it detects proper electrical contact between the torch and the workpiece through this clamp, ensuring that the main laser beam only occurs when this safe working condition exists.

This mechanism prevents accidental activation of the laser, protecting both the operator and anyone else who may be near the equipment.

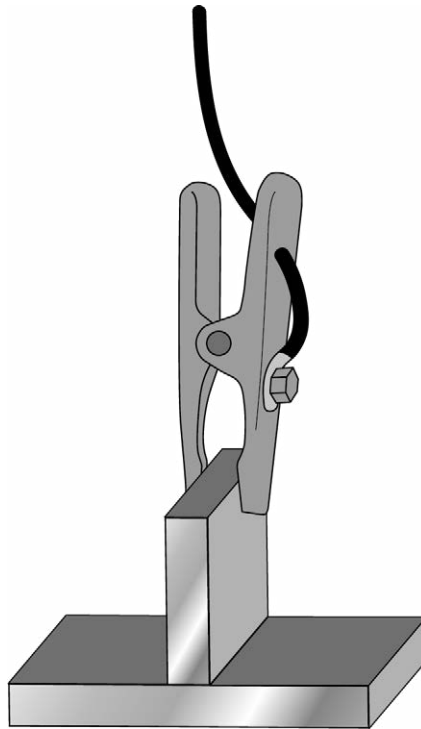

#### **Important**

**Using the equipment without the clamp correctly connected may cause operating errors and represents a serious risk of accident. Always make sure to check its position before each use.**

Prada Nargesa, S.L. is not liable under any circumstance for personal or material damages or derived losses, direct or indirect, caused by the misuse of the equipment.

## 4. NOZZLE SELECTION AND ADJUSTMENT

The choice of the right nozzle depends on several factors that directly affect the quality and stability of the welding process. Nozzles should be selected considering the following aspects:

### 4.1. Type of joint or weld geometry

Depending on the configuration of the parts to be joined:

#### o Butt joint (plate to plate)

It generally requires a single nozzle, since the volume of the filler is usually small and the access to the bead is direct.

#### o T-joint

It may require a greater amount of filler depending on the thickness; the use of double nozzles to ensure correct fusion of both pieces and good gas coverage is recommended.

#### o Overlapping joint

As there is a greater volume of material in the joint, it is usually best to use double nozzles, especially in medium and high thicknesses, to facilitate filling and ensure adequate penetration.

- Material thickness:

The greater the thickness, the larger the nozzle diameter required to allow sufficient wire flow and adequate protection of the molten bath.

- Desired filler amount:

When the process requires a high volume of wire (for example, in thick thicknesses or wide beads), using double nozzles that allow a higher gas flow and better wire distribution is recommended.













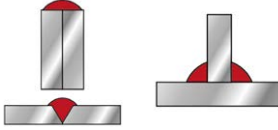

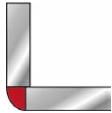



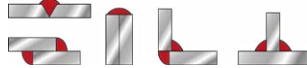

The choice of filler wire thickness is decisive for the final welding result. This should always be selected according to the type of joint, the thickness of the base material and the desired finish.



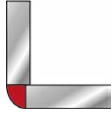

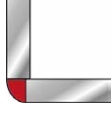

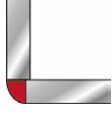

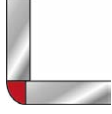

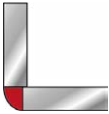

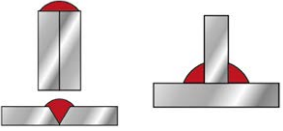
In general:

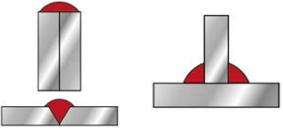
- **For precision welding or thin sheets**, we recommend the use of smaller diameter wires, which allow greater control of the bead and reduce the heat input.

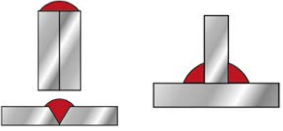
- **For welds in thick materials, joints with volume or filler beads**, using larger diameter wires, capable of providing the volume of material necessary to achieve correct penetration and structural resistance is necessary.

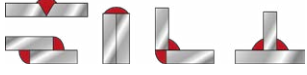
A correct combination of wire thickness, nozzle and process parameters will ensure a high quality, safe and durable weld.

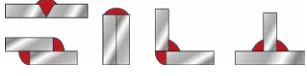
	Description	Wires	Type of welding	Wire Ø	Model
	Ref: 080-MSL-00411 Nozzle for autogenous welding, for flat welds, inside corners and outside corners.	-		-	A
	Ref: 080-MSL-00412 Nozzle for autogenous welding, for flat welds or inside corners.	-		-	B
	Ref: 080-MSL-00413 Nozzle for autogenous welding, for outside corner welding.	-		-	C
	Ref: 080-MSL-00414 Nozzle for welding with filler wire up to 1.0 mm, for flat welding, inside corners and outside corners.	1		1.0 mm	AS-10
	Ref: 080-MSL-00415 Nozzle for welding with filler wire up to 1.2 mm, for flat welding, inside corners and outside corners.	1		1.2 mm	AS-12
	Ref: 080-MSL-00416 Nozzle for welding with filler wire up to 1.6 mm, for flat welding, inside corners and outside corners.	1		1.6 mm	BS-16
	Ref: 080-MSL-00417 Nozzle for welding with filler wire up to 2.0 mm, for flat welding, inside corners and outside corners.	1		2.0 mm	BS-20
	Ref: 080-MSL-00418 Nozzle for welding with filler wire up to 1.0 mm, for outside corner welding.	1		1.0 mm	CS-10
	Ref: 080-MSL-00419 Nozzle for welding with filler wire up to 1.2 mm, for outside corner welding.	1		1.2 mm	CS-12
	Ref: 080-MSL-00420 Nozzle for welding with filler wire up to 1.6 mm, for outside corner welding.	1		1.6 mm	CS-16
	Ref: 080-MSL-00421 Nozzle for welding with filler wire up to 1.2 mm, for outside corner welding.	1		1.2 mm	ES-12

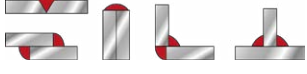
	Description	Wires	Type of welding	Wire Ø	Model
	Ref: 080-MSL-00431 Nozzle for welding with filler wire up to 1.6 mm, for outside corner welding.	1		1.6 mm	ES-16 FS-16
	Ref: 080-MSL-00422 Nozzle for welding with filler wire up to 1.0 mm, for flat welding and inside corners.	1		1.0 mm	DS-10
	Ref: 080-MSL-00423 Nozzle for welding with filler wire up to 1.2 mm, for flat welding and inside corners.	1		1.2 mm	DS-12
	Ref: 080-MSL-00424 Nozzle for welding with filler wire up to 1.6 mm, for flat welding and inside corners.	1		1.6 mm	DS-16
	Ref: 080-MSL-00425 Nozzle for welding with dual filler wire feed up to 1.2 mm, for flat welding, inside corners and outside corners.	2		1.2 mm	AS-12D
	Ref: 080-MSL-00426 Nozzle for welding with dual filler wire feed up to 1.6 mm, for flat welding, inside corners and outside corners.	2		1.6 mm	AS-16D
	Ref: 080-MSL-00427 Nozzle for welding with dual filler wire feed up to 2.0 mm, for flat welding, inside corners and outside corners.	2		2.0 mm	AS-20D

## 5. FORESEEABLE MISUSES

Although the MS20 has been designed to provide a high level of safety and reliability, there are foreseeable misuses that must be strictly avoided to ensure the safety of the operator, the proper functioning of the system and the integrity of the working environment.

The most common or foreseeable misuses are listed below:

### 5.1. Technically incorrect uses

- **Failure to connect the safety clamp correctly** or connect it to the torch.
- The minimum permissible bending radius for both the hose and the yellow fiber optic cable inside it is 20 cm (7.9"). **Under no circumstances should this bending radius be forced or reduced.** A bending radius smaller than the specified value may cause internal damage to the fiber optic cable, affecting system performance and potentially leading to serious equipment failure.
- **Forcing the MS20 to cut out-of-specification materials**, such as carbon steel over 4 mm thick.
- **Ignoring maintenance cycles of the chiller**, which may cause overheating.
- **Soldering incompatible or hazardous materials**, such as lead, PVC, which may release toxic gases or damage optics.
- **Operating without personal protective equipment (PPE)**, especially without approved laser goggles.

### 5.2. Recreational or inappropriate uses

- **Firing the laser on balloons, fruits, wood or flammable materials** for playful or demonstration purposes.
- **Aiming the laser at people, animals or reflective surfaces** out of curiosity or error.
- **Using the equipment for "games" or experiments in social media**, such as videos of explosions or unauthorized recording.
- **Igniting objects with the laser as if it were a source of heat or flame**, e.g. cigarettes or paper.
- **Welding on containers with flammable or unknown substances.** Never weld on containers that have contained combustible or toxic materials or have been subjected to pressure. There is a risk of explosion or release of hazardous gases.

### 5.3. Unauthorized tampering

- **Modifying the safety parameters of the system**, such as sensors, locks or alarms.
- **Opening the case or handling internal components while the equipment is on.**
- **Using non-original parts or spare parts**, which may compromise safety and void the warranty.
- **Allowing use by untrained or unauthorized personnel**, including minors.
- **Removing or altering security labels.** Warnings and danger signs must remain visible and legible at all times. Their elimination may lead to risky situations.

### 5.4. Legal warning

Any use other than as indicated by the manufacturer voids the warranty, compromises safety and exempts the manufacturer from any liability for material or personal damage resulting from misuse of the equipment.

## 5.5. Ban on operating with deteriorated safety mechanisms

Carrying out any work operation on the MS20 NARGESA laser welder is strictly forbidden if any of the safety mechanisms are damaged, manipulated, misadjusted or out of service.

The following are considered safety mechanisms, among others:

- Fixed and movable fairings and guards on the MS20 or in the welding zone.
- Laser protective lens.
- Laser focusing lens.
- Laser collimation lens.
- Laser fiber protective hose and end fittings
- Laser head housing
- Emergency stops (emergency push buttons).
- Any other device intended to prevent exposure to the laser beam or hazardous movements.

When a deteriorated or malfunctioning safety mechanism is detected, the following instructions must be followed:

1. **Immediately stop the MS20** by using the normal stop or, if necessary, the emergency stop.
2. **Do not resume work** until the safety mechanism has been inspected, repaired or replaced by authorized personnel (maintenance service or approved TAS).
3. **Mark the MS20 as "OUT OF SERVICE"**, e.g. by visible sign or label, to avoid accidental use.
4. **Inform the production/maintenance manager** and record the incident in accordance with the internal company procedure.
5. **The following is expressly forbidden:**
  - Bridging microswitches or safety limit switches.
  - Locking guards in an open position.
  - Overriding emergency stops or illuminated signals.
  - Any modification to the safety systems that is not authorized by the manufacturer.

Failure to comply with this rule may result in:

- Hazardous exposure to laser radiation.
- Projections of sparks, smoke or metallic particles.
- Burns, serious eye injuries and other accidents.

## 5.6. Checking the emergency shutdown and safety components

As part of the preventive maintenance of the MS20 NARGESA, the correct operation of the emergency stop and the rest of the safety components must be checked periodically.

The verifications will be carried out with the equipment in operation, following the safety instructions in this manual.

### Items to be checked:

- Emergency stops (push buttons) and their resetting.
- Laser locking key.
- Safety unit.
- Indicator lights and/or MS20 status and laser emission.
- Any other safety devices installed on the MS20.

**General verification procedure:**

1. Activate the emergency stop and check that:
  - The MS20 stops immediately.
  - It is not possible to restart the cycle while the emergency stop is engaged.
2. Reset the emergency shutdown and verify that:
  - It is only possible to restart the unit using the corresponding start command.
3. Check the correct operation of the light signals (laser emission, equipment in operation, failure, etc.).

**Registration and performance:**

- All checks shall be recorded in the company's preventive maintenance sheet or system (date, operator, result).
- If any anomaly detected (device that does not work, works irregularly or has been tampered with), the MS20 shall be put OUT OF SERVICE until the safety system is repaired by authorized personnel.
- It is prohibited to override, bypass or modify any safety components to continue production.

## 6. RISKS WITH THE EQUIPMENT

### 6.1. List of residual risks with the equipment



Burn



Tripping



Electrocutation



Crushing



Falling objects at different levels



Hazards generated by laser beams (direct or reflected): in industrial laser applications, especially with manual laser welding equipment, bear in mind that very intense and dangerous radiation may be found behind the workpiece (direct propagation), reflected in any direction opposite to the operator's area (flat workpieces), or even reflected towards the operator themselves (curved surfaces, corners, inclined workpieces, etc.).

### 6.2. List of general risks with the equipment



Laser risk category

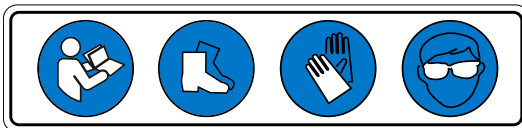

General warnings



Electrical hazard



Laser risk

## 7. LENS REPLACEMENT (PROTECTIVE AND FOCUSING)

### Safety warning:

The optical lens is an extremely sensitive component and must be handled with extreme care to avoid damage or contamination. The entire procedure must be carried out on a clean, dust-free surface, properly illuminated and with the torch in the corresponding holder.

### 7.1. Tools and materials needed

Prepare the following material for proper lens replacement:

- The new replacement lens.
- Rubber gloves or finger protective covers.
- Clean adhesive tape (preferably with low adhesiveness for optics).
- A suitable screwdriver.
- Lint-free cleaning cloths (optional).

### 7.2. Procedure for replacing the protective lens

Following the steps below for proper lens replacement:

#### 1. Preparing the work area

- Be sure to work on a clean, flat and dust-free surface.
- Press the emergency stop button to stop the equipment.
- Use appropriate protection to avoid lens contamination (rubber gloves or finger covers).
- Position the head in the magnetic holder.

#### 2. Disassembly of the protective lens assembly.

- Locate the lens carrier on the head.

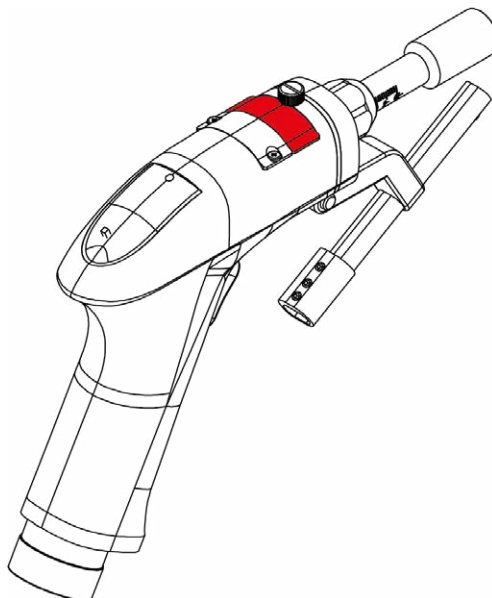

- Unscrew the fixing screw that holds the lens in its housing and remove the lens holder.

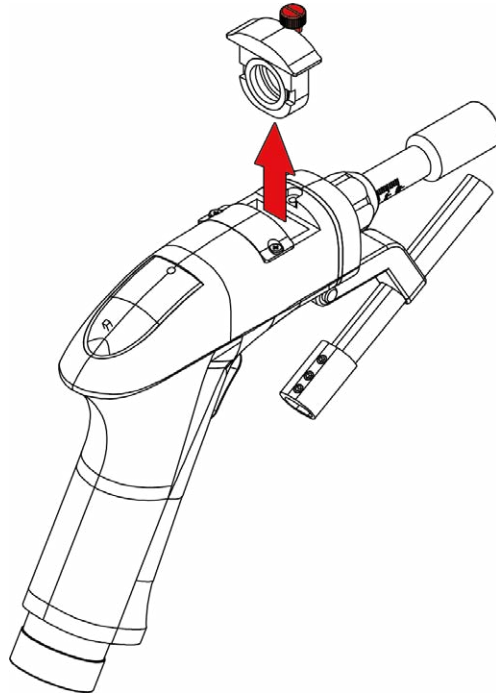

### 3. Housing sealing

- Cover the access hole with clean adhesive tape once the screw has been removed.  
*This step is essential to prevent dust or particles from entering while handling the lens.*

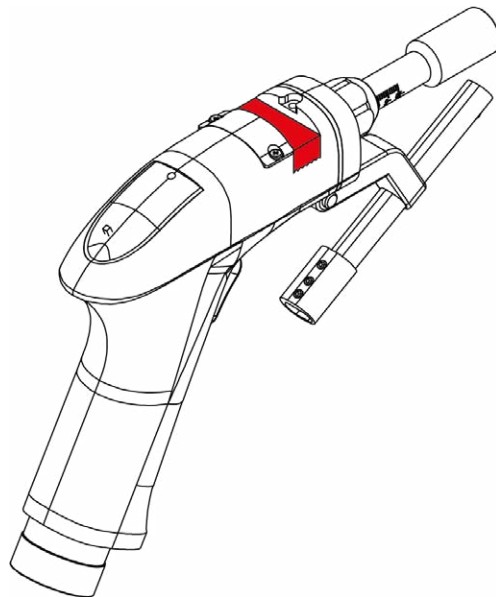

4. Removing the O-ring

- Remove the O-ring that secures the lens in position.

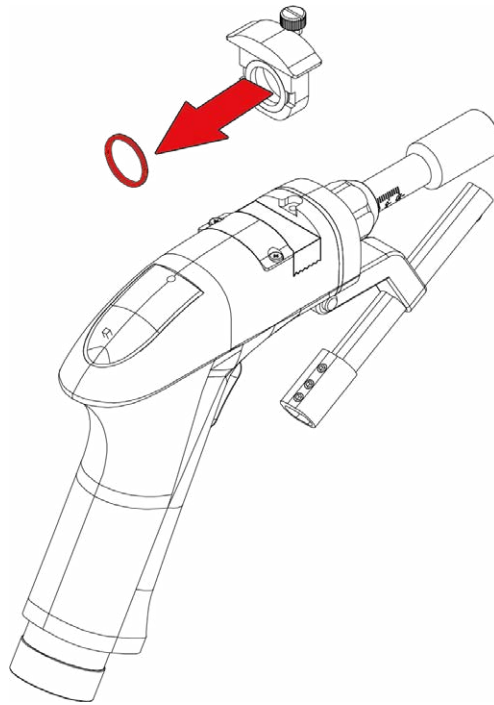

5. Removing the used lens

- Remove the lens.

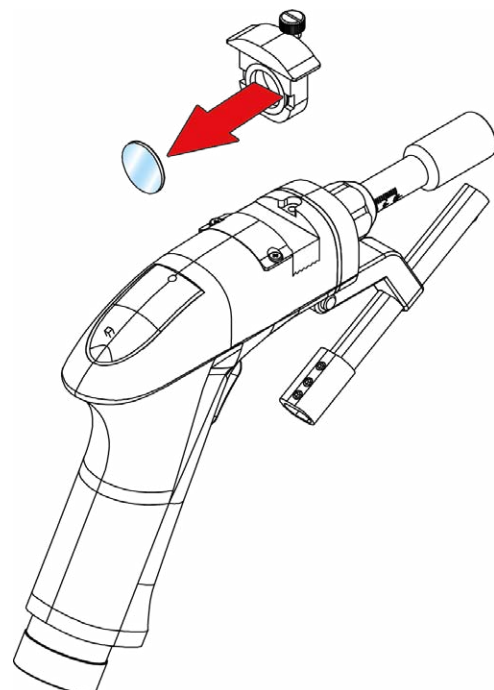

6. Installing the new lens

- Before fitting the new lens, check that it is clean and free of particles.
- Always handle the lens by the edge only, using rubber gloves or finger covers.
- Insert the lens into the housing, making sure that it is correctly seated.

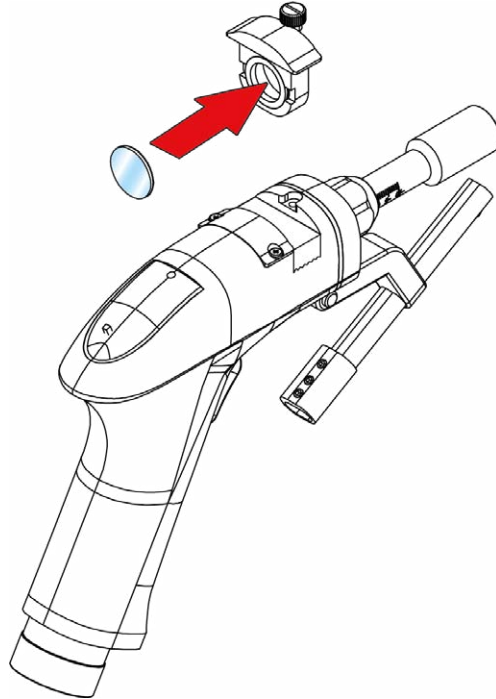

- Put the O-ring back in position to secure the lens.

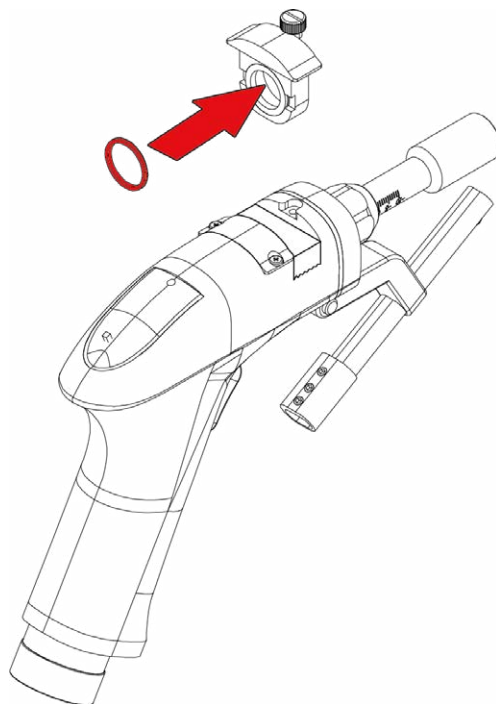

7. Remove the adhesive tape

- Once the lens is mounted and secured, remove the adhesive tape that sealed the hole.

8. Final assembly

- Fit the lens holder in the correct position and secure the fixing screw.

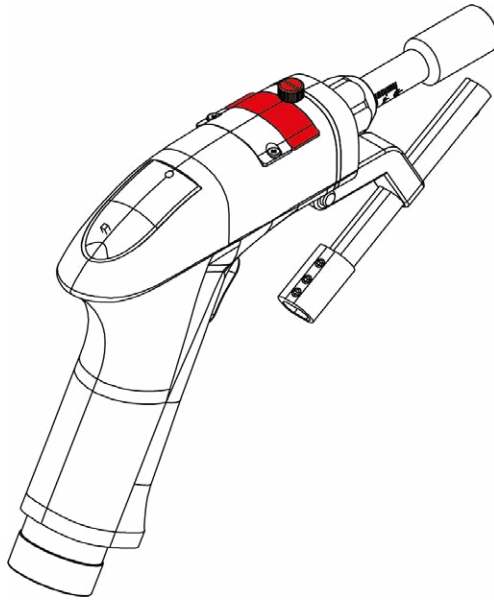

- Check that the lens is correctly positioned and fixed.

**Warning:**

- Review corrective maintenance to determine why the lens has burned out.
- If the new lens becomes accidentally contaminated during the procedure, it must be replaced with a new one.
- Do not use industrial compressed air, tissues or non-approved liquids.

### 7.3. Procedure for replacing the focusing lens

#### 1. Preparing the work area

- Make sure to work on a clean, flat and dust-free surface.
- Press emergency stop to stop the equipment.
- Use adequate protection to avoid contamination of the lens (rubber gloves or finger covers).
- Position the head in the magnetic holder.

#### 2. Disassembling the focusing lens assembly.

- Locate the lens carrier on the head.

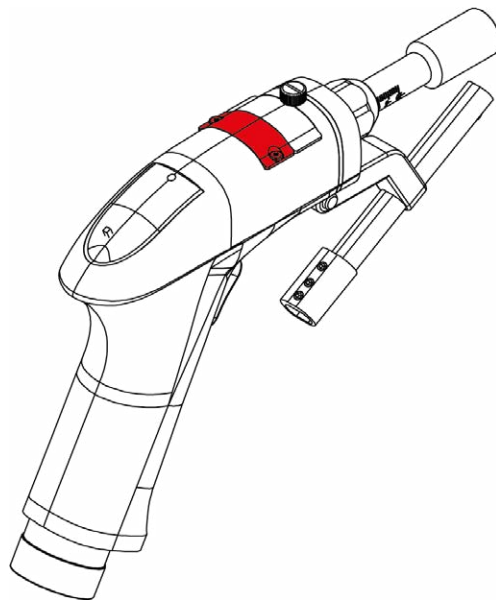

- Unscrew the two fixing screws that hold the lens in its housing and remove the lens holder.

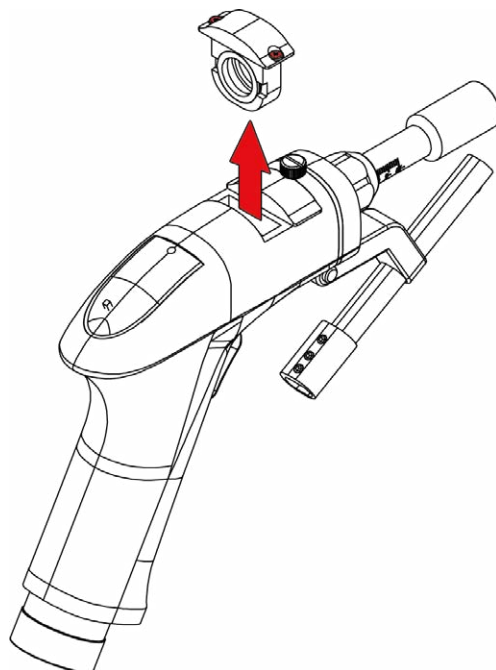

### 3. Housing sealing

- Cover the access hole with clean adhesive tape.

*This step is essential to prevent dust or particles from entering while handling the lens.*

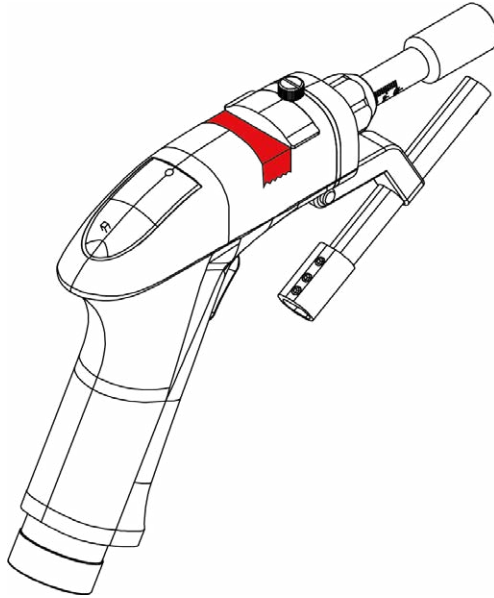

### 4. Removing the O-ring

- Carefully remove the O-ring that secures the lens in position.

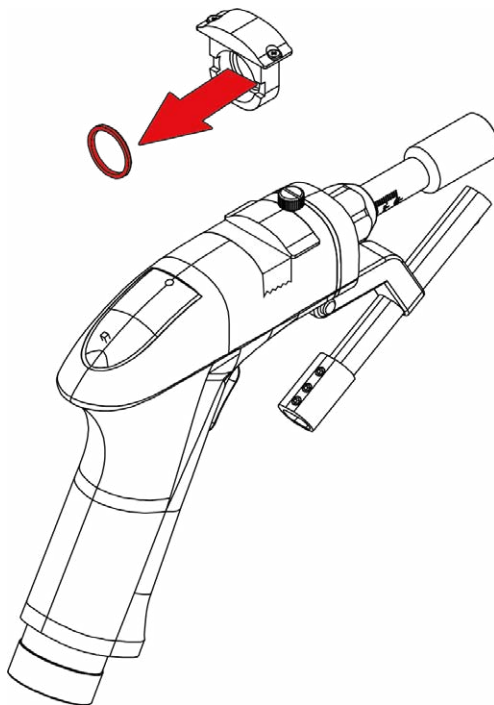

5. Removing the used lens

- Remove the lens.

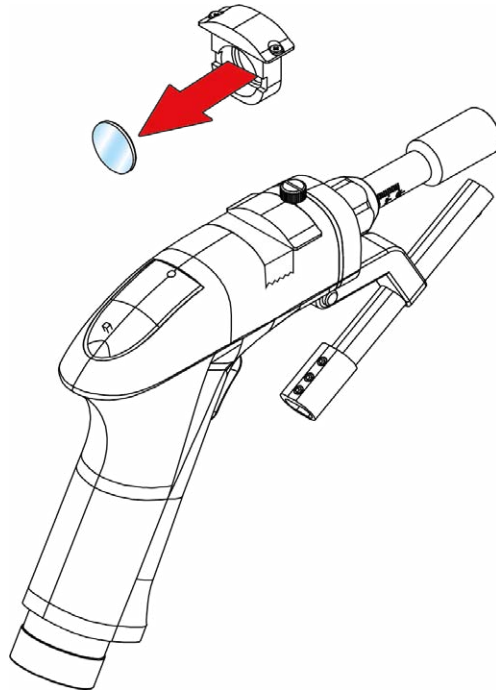

6. Installing the new lens

- Before inserting the new lens, you must verify that it is clean and free of particles.
- Always handle the lens by the edge only, using rubber gloves or finger covers.
- Insert the lens into the housing, making sure that it is correctly seated.

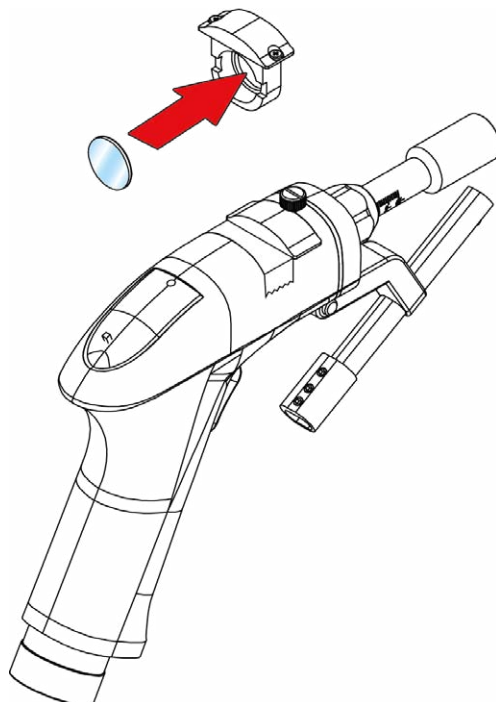

- Put the O-ring back in position to secure the lens.

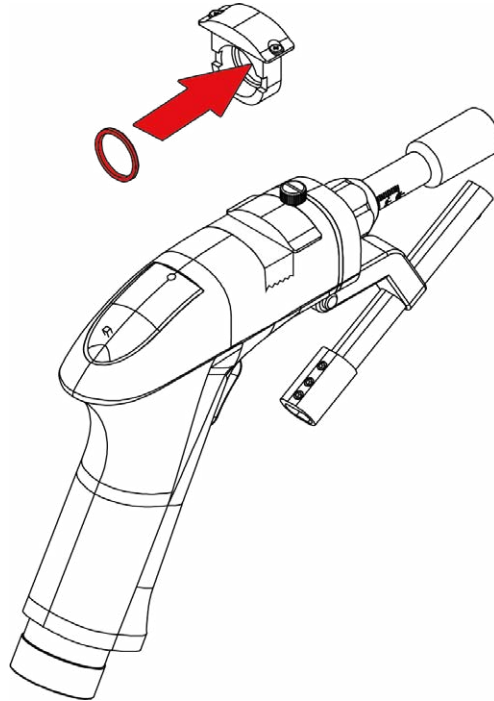

7. Remove the adhesive tape

- Once the lens is mounted and secured, remove the adhesive tape that sealed the hole.

8. Final assembly

- Fit the lens holder in the correct position and secure the fixing screw.

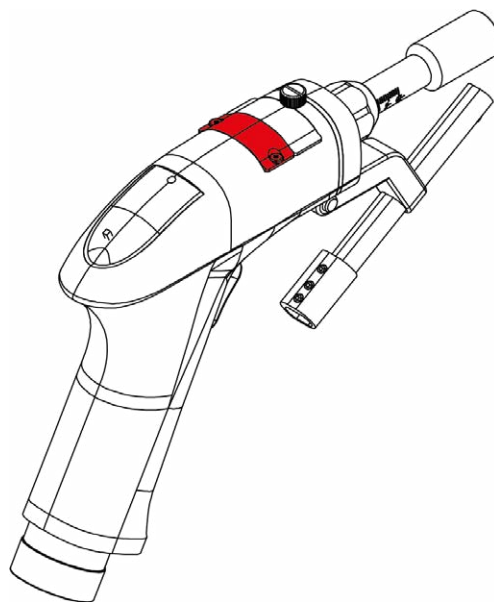

- Check that the lens is correctly positioned and fixed.

**Warning:**

- Review corrective maintenance to determine why the lens has burned out.
- If the new lens becomes accidentally contaminated during the procedure, it must be replaced with a new one.
- Do not use industrial compressed air, tissues or non-approved liquids.

## 8. REPLACING THE WIRE

### Initial preparation and removal of old wire

1. Cut the tip of the wire before removing.

This prevents possible imperfections or deformations in the tip from scratching the inside of the wire rope during removal.

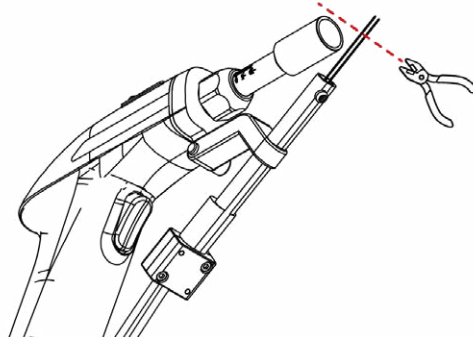

2. Release the tensioners from the drags by placing them in horizontal position.

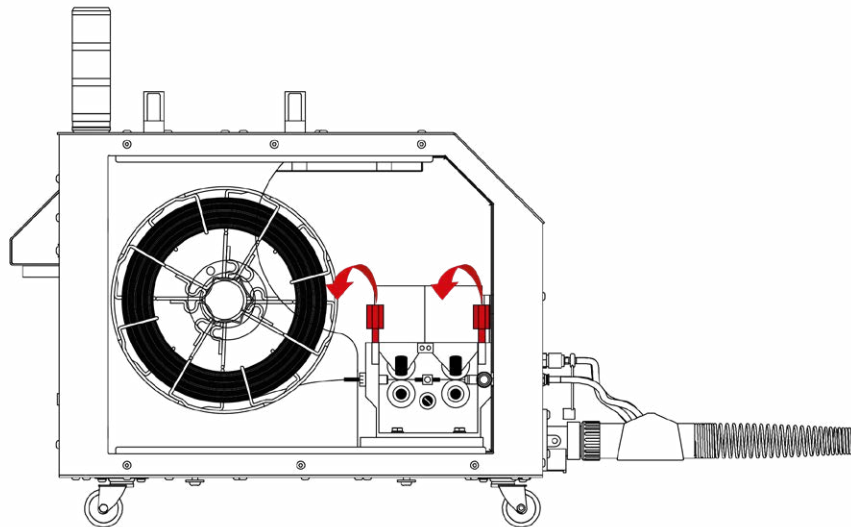

3. Rewind the wire by manually turning the reel of origin.

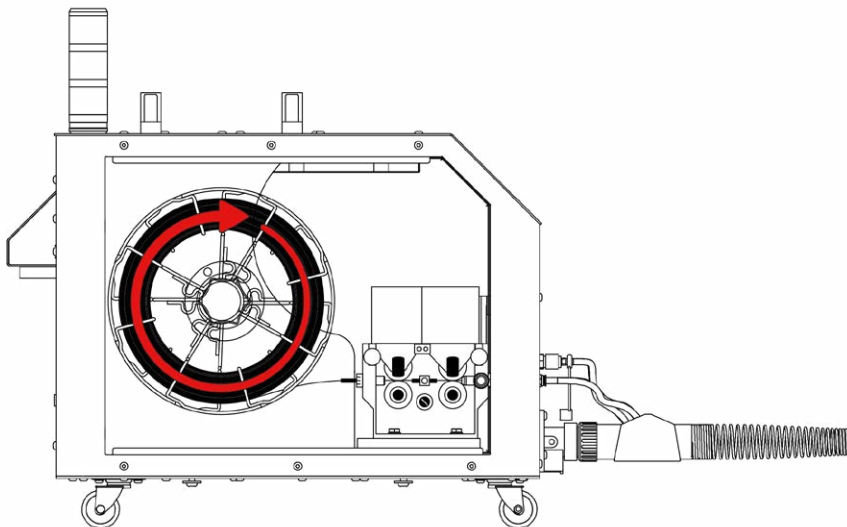

**Replace the wire rope (wire guide)**

4. Loosen the four Allen screws (1) and the two screws (2) located at the end of the torch, which secure the wire rope clamping piece inside the wire guide.

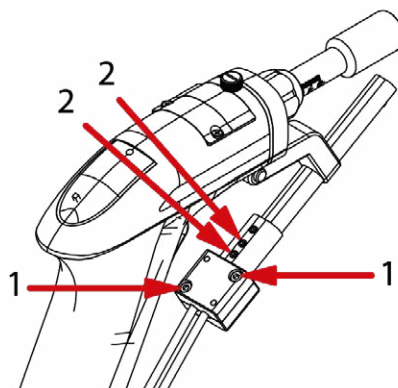
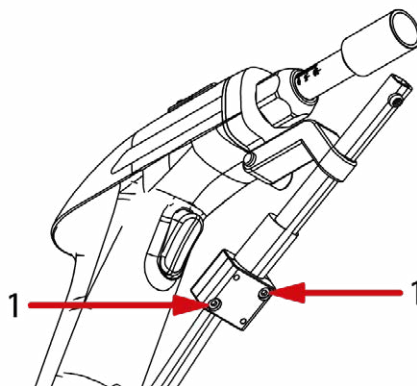

5. Loosen the set screw of the wire input terminal (located on the feeder).

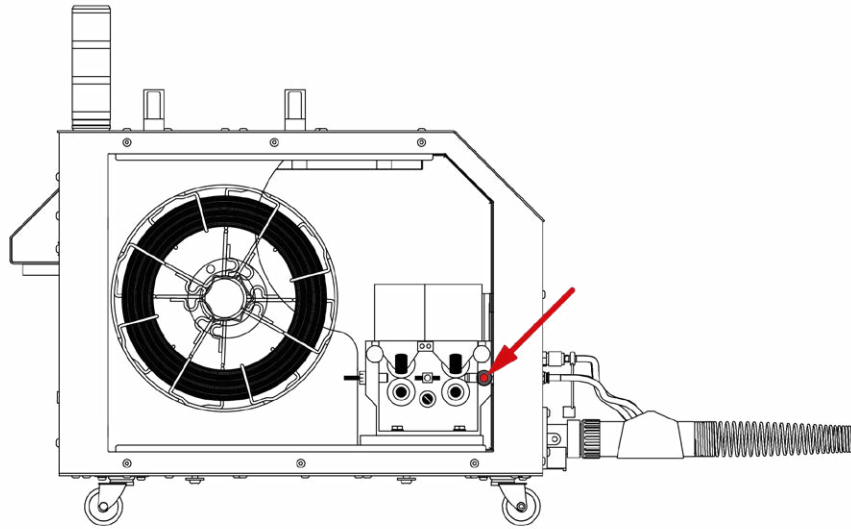

6. Completely remove the terminal from the front of the feeder.

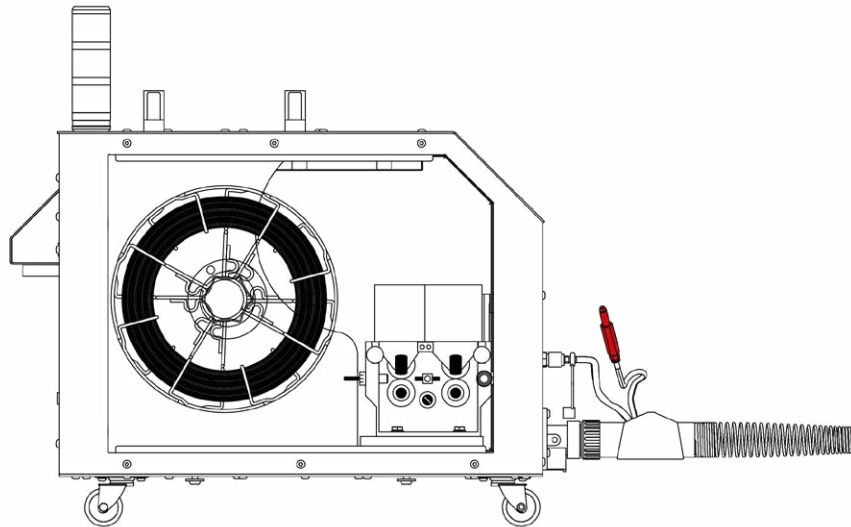

7. Untwist the wire entry point to be able to remove the wire rope.

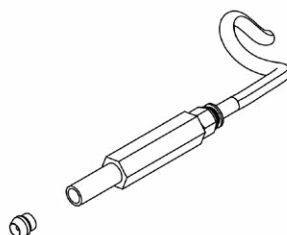

8. With one hand holding the wire rope guide tube and the other hand holding the end fitting, press them against each other. At the same time, press on the blue or red washer to release the tube from the fitting.

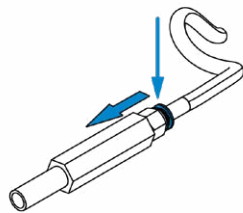

9. Keeping pressure on the blue washer, separate the guide tube from the terminal by 5 centimeters and reattach them.

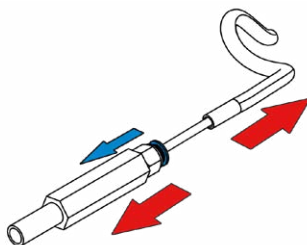

10. Remove the wire rope completely.

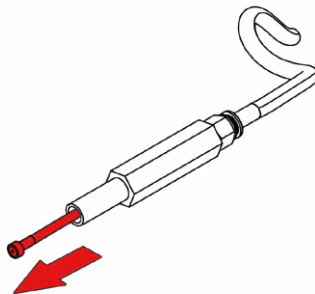

11. Cut the new wire rope with pliers to adjust the correct distance of the new wire rope. Use the old wire rope to cut the new one to the same length.

In the case of steel (iron) wire rope: if the cut must be made at the end that already has a plastic sleeve. Once the wire rope has been cut, remove the last 5 cm of this sleeve to leave the end free. In the case of aluminum wire rope: unscrew the metal part at the end of the wire rope.

Once the wire rope has been cut, screw the metal part back on, and it should be the same length as the wire rope that has been removed.

12. Insert the new wire rope corresponding to the diameter of the wire to be used.

*\* Make sure that the wire rope enters the torch housing correctly.*

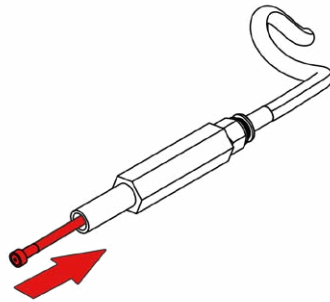

13. Twist the wire entry point.

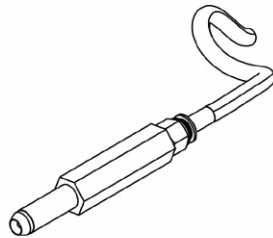

14. Cut 132 mm of Ø4.5 heat-shrink tubing and insert it into the end of the wire rope.

15. To fit the wire rope to the torch, the end of the new wire rope must be inserted into the clamping piece.

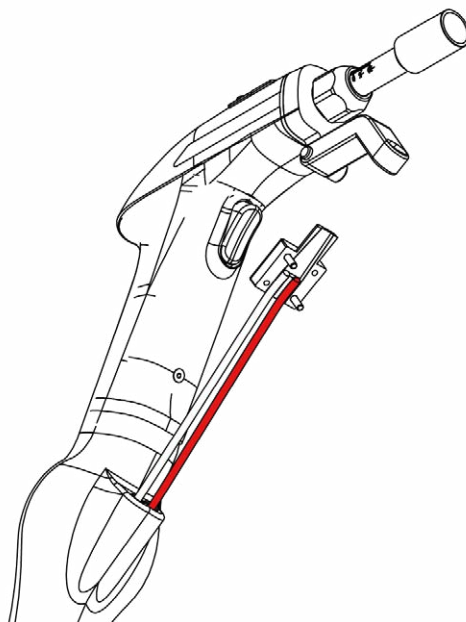

16. Retighten the four Allen screws (1) to fix the wire ropes to the clamping piece and the two screws (2) to fix the wire guide.

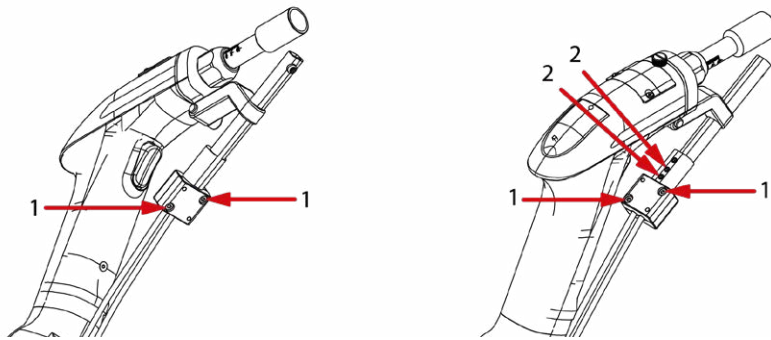

17. Return the terminal to its initial position from the front of the feeder, making sure that it is fully positioned against the feeder.

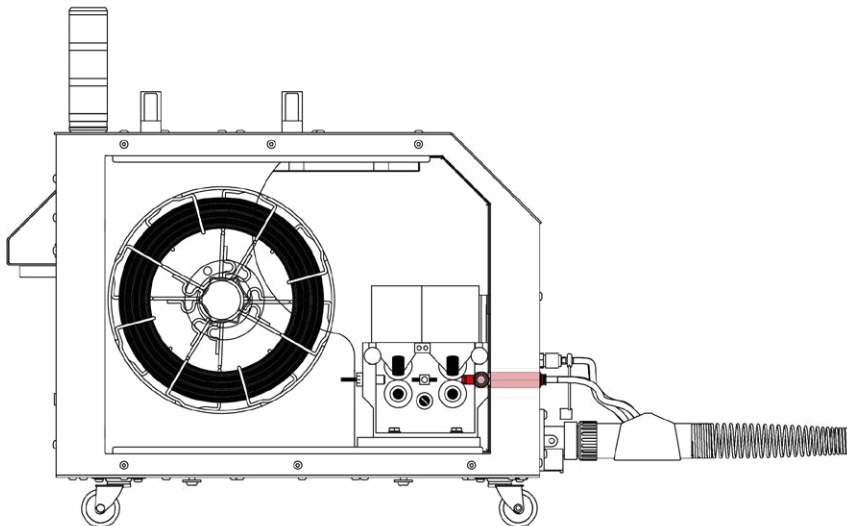

18. Secure the screw again.

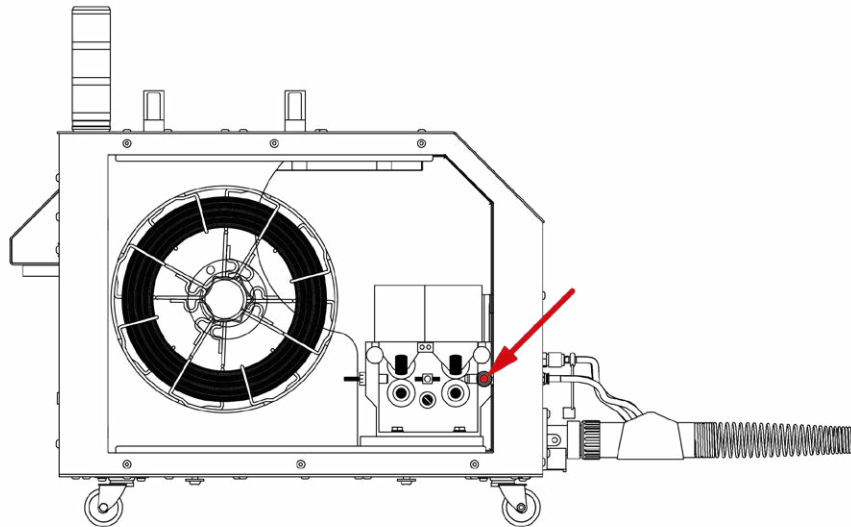

**Adjust the drives and rollers**

19. Unscrew the retaining screws of the rollers and remove them. Remove the two washers.

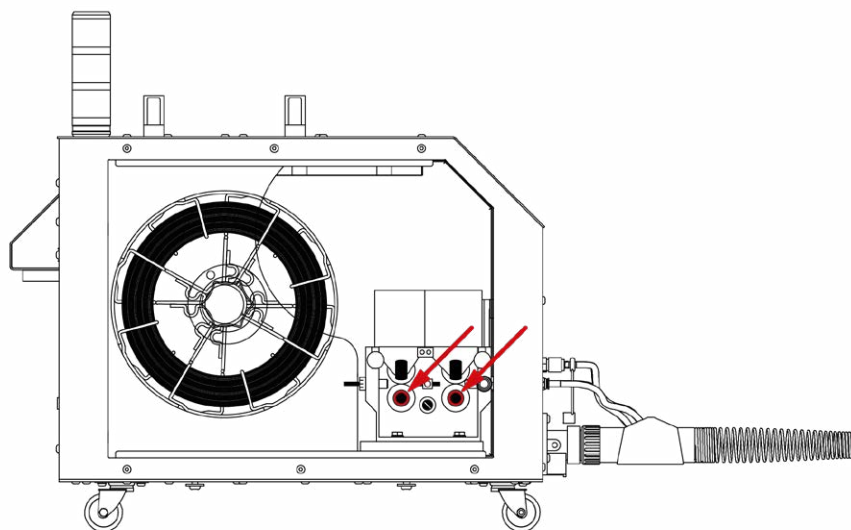

20. Replace the drive rollers with ones that are compatible with the new wire diameter. Position the washers and screw the screws.

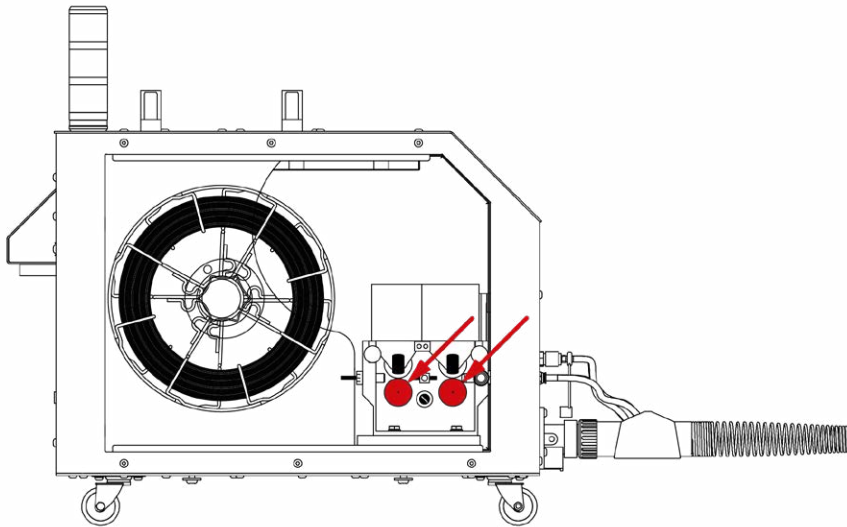

*\* It is important to note that the rollers are marked indicating the wire size. Once in place, the numbering seen on the front of the roller corresponds to the measurement of the rear trench; in other words, where the wire will pass through.*

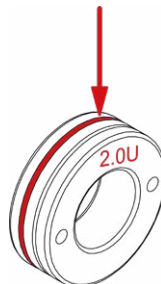

### Loading the new wire

21. Replace the current reel with the new reel (or reels) in the corresponding holder.

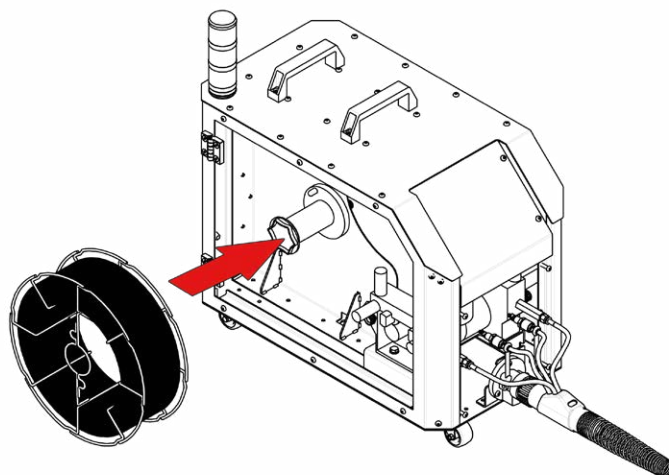

22. Insert the new wire into the drag system manually until the wire enters one centimeter into the end fitting previously assembled.

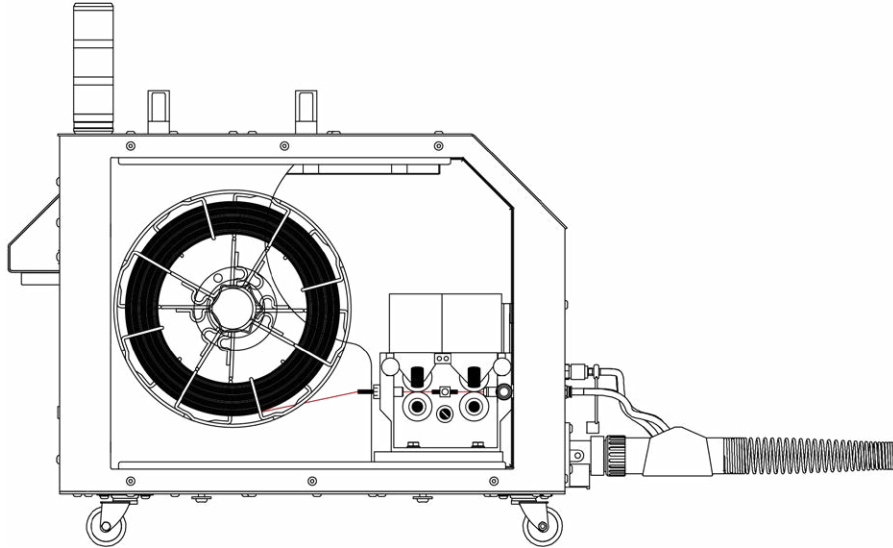

23. Secure the tensioners of the drags by placing them in a vertical position.

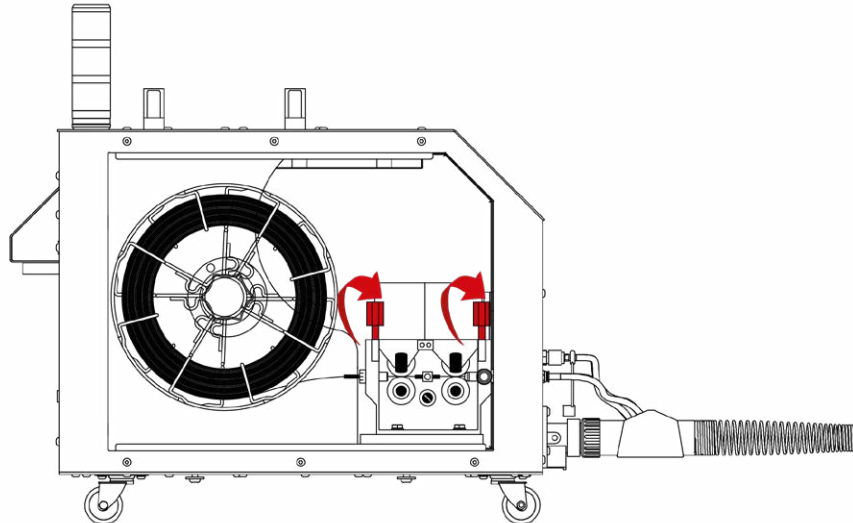

24. Feed the desired wire, following the steps described in section 13.3.1. **Load the welding wire** until it comes out of the end of the welding head.

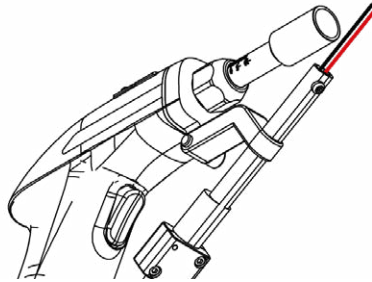

**Final assembly**

25. Install the appropriate exit tip for the new wire diameter.

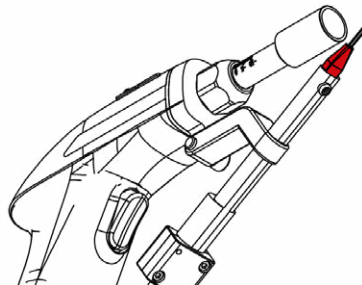

26. Adjust and tighten the toe cap correctly in the housing.

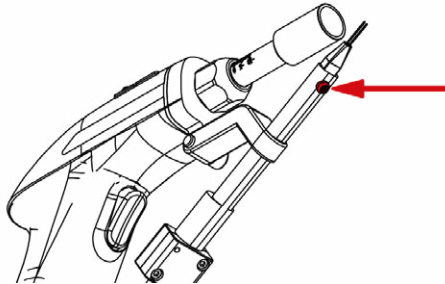

27. Cut the excess wire to leave the correct operating length.

*\* The equipment is now ready to weld with the new wire installed.*

## 9. INSTRUCTIONS FOR USE

### 9.1. Start-up

1. Position the on/off switch in the Connected position.
2. The screen will display the initial interface (Start menu).

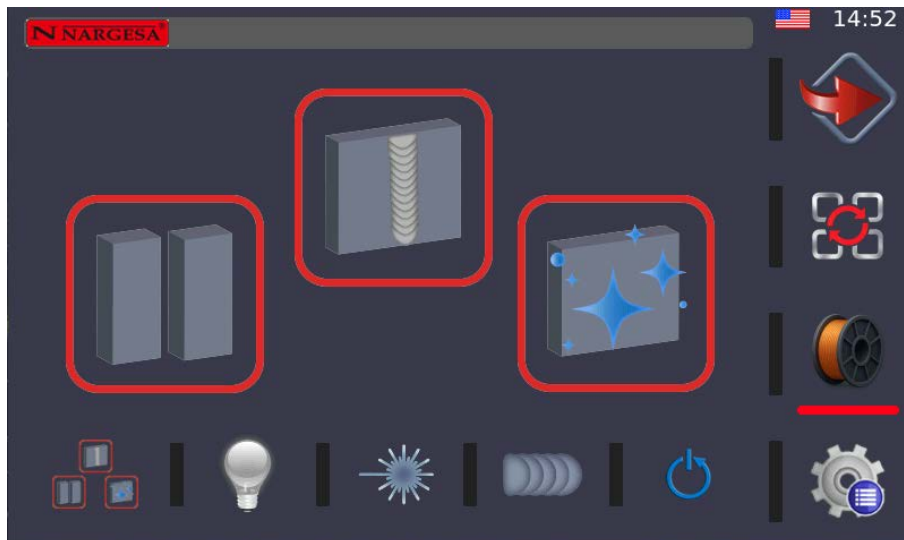

The MS20 will not be in standby, i.e. it is activated, but remains idle waiting to perform any function:



Cut mode



Weld mode



Clean mode

### Eco mode (energy saving)

The welder is delivered with the eco mode activated by default. This mode reduces consumption when periods of inactivity are detected, automatically stopping the most energy-demanding elements and automatically reactivating them when work resumes.

Benefits:

- **Energy efficiency:** reduces consumption during operational breaks.
- **Sustainability:** helps reduce the environmental impact.
- **Competitiveness:** lower energy cost per part.

Note: Eco mode requires no operator intervention to reactivate subsystems; the MS20 starts them automatically upon detected any new operation

### 9.2. Cut mode

To access the cut mode, proceed as follows:

From the start menu, select cut mode .

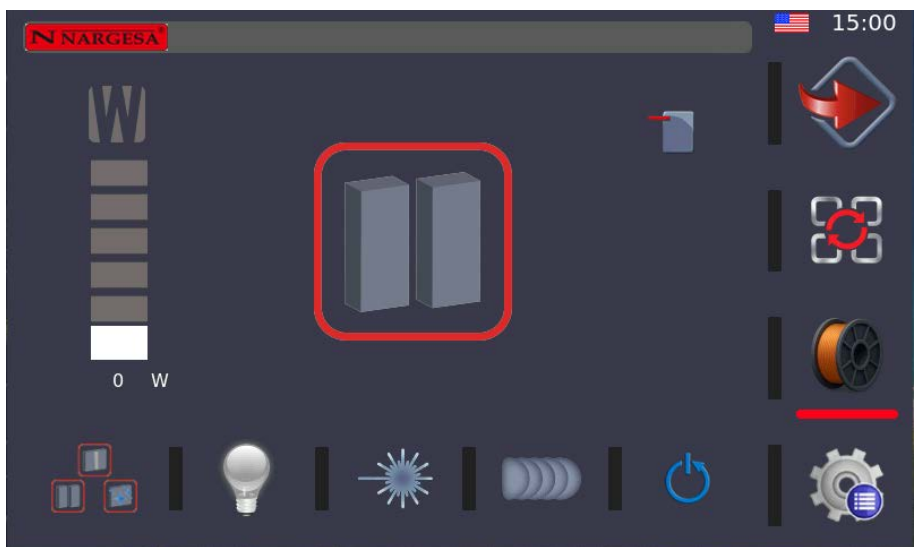

To enter the parameters, press  and the control will open this page:



**Parameter settings**

In the parameters page, you will configure the following options:

The control allows you to select the type of material to be cut, the thickness to be cut, the type of gas to be used for cutting and the type of nozzle of the laser head.

**1. Material**

o Press Material  to select the type of material to cut.

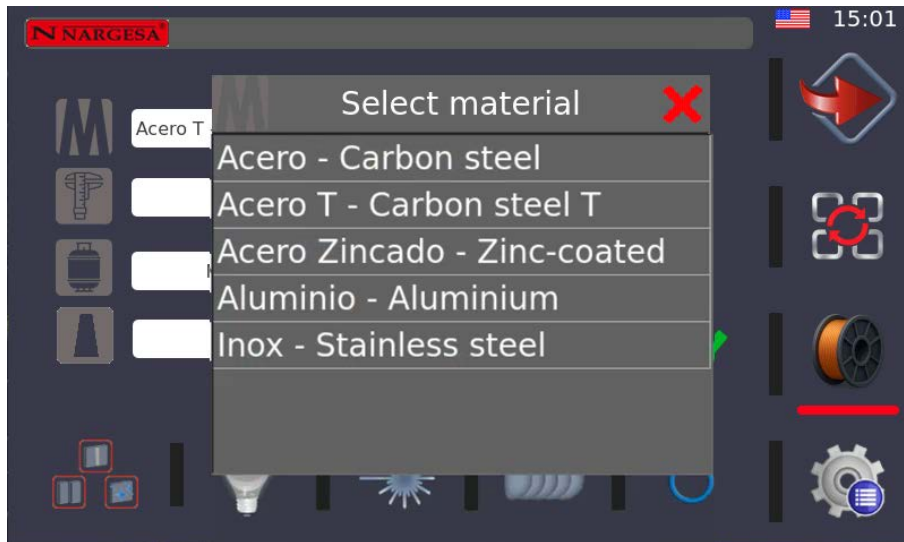

**2. Thickness**

o Press Thickness  and choose the value corresponding to the material.

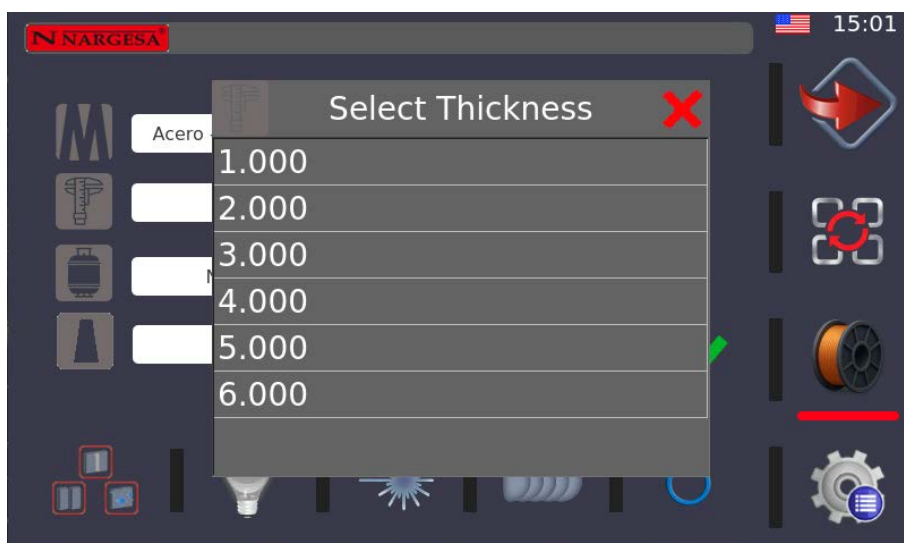

### 3. Cutting gas

Press Gas  and select the gas to be used: Nitrogen, Gas Mix or Argon.

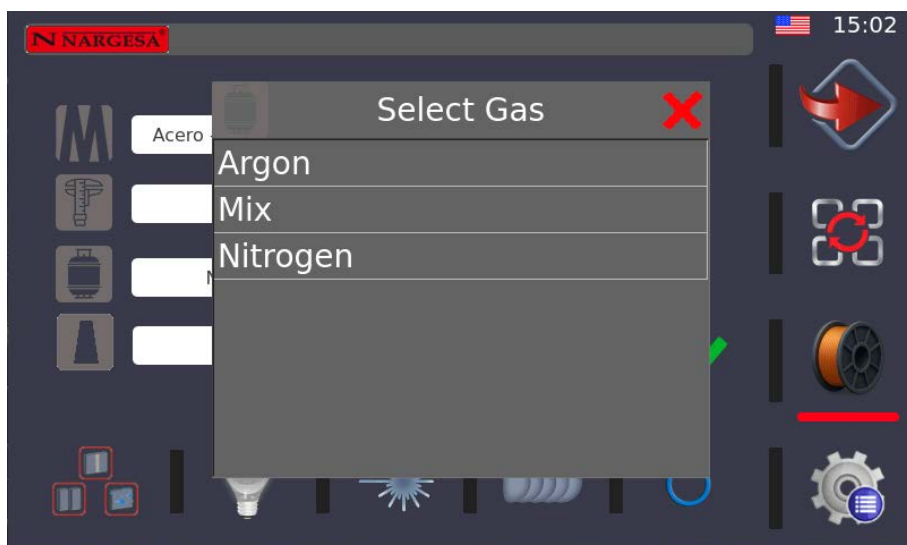

Gas recommendations:

- Nitrogen (N<sub>2</sub>)

Nitrogen is the most commonly used option for cutting non-ferrous metals (such as stainless steel or aluminum) and in applications where a clean, rust-free edge is required.

Its inert nature prevents the formation of oxides on the cut surface, maintaining the original metallic color of the material. In addition, it favors thermal evacuation and allows high cutting speeds.

The recommended operating pressure is between 8 and 18 bar, depending on the thickness and type of material.

- Argon (Ar)

Argon is mainly used for cutting aluminum and light alloys, where its high density and inert character guarantee effective protection against oxidation.

It provides stable and precise cuts, although with higher operating costs and a lower cutting speed than Nitrogen.

It is ideal for high surface quality work or parts requiring minimal thermal alteration.

Typical operating pressure: 6 to 10 bar.

- Gas Mix (82% Argon + 18% CO<sub>2</sub>)

The recommended Gas Mix (82% Argon + 18% CO<sub>2</sub>) offers an optimum balance between performance and cost in cutting applications on carbon steels and structural steels.

CO<sub>2</sub> acts as an active gas, favoring greater penetration and expulsion of the molten slag, while Argon stabilizes the process and improves edge quality.

The result is an efficient, economical cut with moderate oxidation, suitable for parts that will later be painted or machined.

The usual operating pressure is between 6 and 10 bar.

Other commercially available mixtures can be used, but the 82% Ar + 18% CO<sub>2</sub> ratio is recommended as the standard configuration.

#### 4. Nozzle

- Press  to select the nozzle type compatible with the laser head.

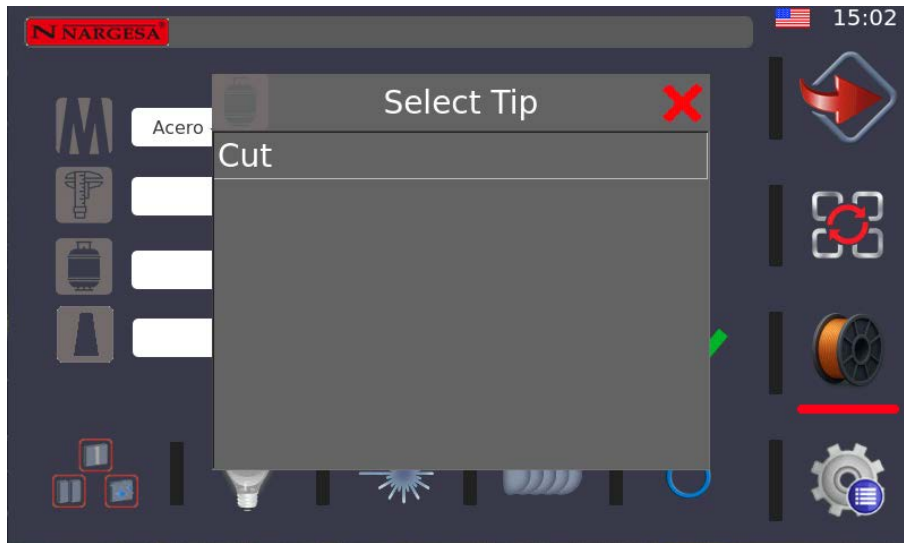

Select Cut which is the cutting nozzle.

After this you will press  and the CNC will load the recipe to be able to make the cut.

Then simply press  and the CNC will display an image like this:

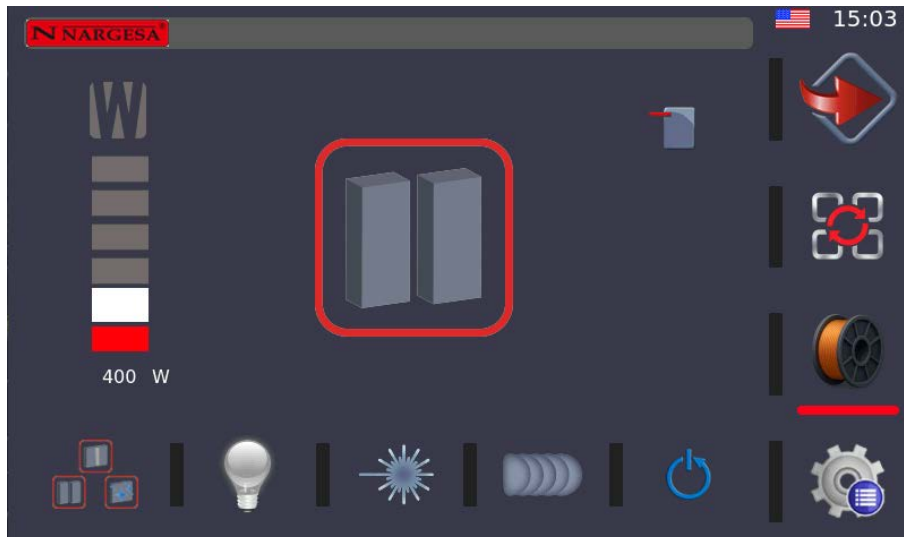

It should be noted that the MS20 is prepared for cutting: the safety unit has to be connected and all external security measures must be in place.

## **5. Cutting**

Once the parameters corresponding to the cut mode have been selected and confirmed, you verify that the nozzle installed is suitable for the process and that it matches the one selected in the interface. Also confirm that the cutting gas, pressure and material chosen match the values defined on the panel. With these checks completed, the equipment is ready to start cutting.

To make the cut, the nozzle is placed directly on the surface of the material, keeping the head in a vertical position with respect to the sheet. This position ensures proper ejection of the molten material and allows the beam to maintain proper focus throughout the process.

Once the head is positioned, press the trigger to start cutting.

During the operation, the operator must manually move the head along the desired path. It is important to maintain a constant feed rate in accordance with the loaded parameters, avoiding abrupt variations that may generate burrs, interruptions in cutting or loss of penetration.

The nozzle must remain in contact with the workpiece at all times, as this ensures the correct focal distance and allows cutting in complete safety for the operator, guaranteeing process stability and beam containment within the working area.

It is essential to verify that the surface below the material to be cut does not contain elements susceptible to damage or flammable materials. Once through the sheet metal, the laser beam will continue its path and can pierce, burn or damage anything underneath.

At the end of the scribing process, the trigger is released and the head is gently withdrawn.

### **9.2.1. Troubleshooting**

#### **Laser centering**

It is crucial that the nozzle is perfectly centered with respect to the laser beam. Misalignment causes the beam to impinge on the inner walls of the nozzle, which can damage the nozzle and affect the quality of the process.

See section ***Laser centering*** for the detailed procedure.

#### **Focal point adjustment**

The focal point is the area where the laser concentrates its maximum energy. If the focus is offset, the MS20 will not cut correctly, will generate burrs and will produce inaccurate cuts. Since the beam travels through the fiber and through the entire optical chain of the head, the settings may vary depending on the optics installed.

See section ***Setting the focal point*** for the recommended procedure.

#### • Cutting does not start

Probable cause: incomplete parameters or equipment in standby.

Action: apply parameters and confirm Ready status.

#### • Irregular cut or burrs

Probable cause: worn/clogged nozzle, inadequate gas pressure or incorrect feed/power.

Action: replace/clean the nozzle, adjust the gas pressure and check the recipe.

- Excess temperature

Probable cause: insufficient thermal management.

Action: use N<sub>2</sub> (if applicable), replace optics, check calibration and parameters.

To return to the start menu, press the key 

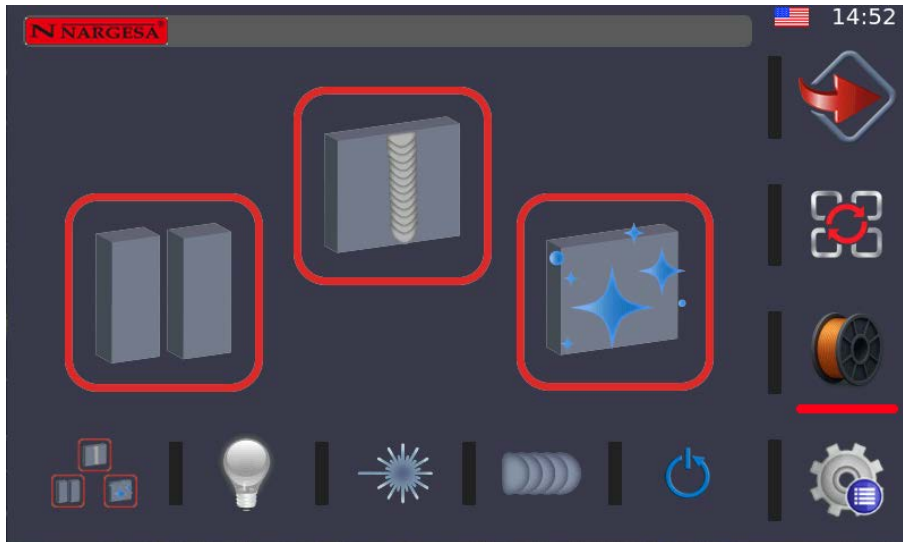

### 9.3. Weld mode

Select this icon  and enter the weld mode.

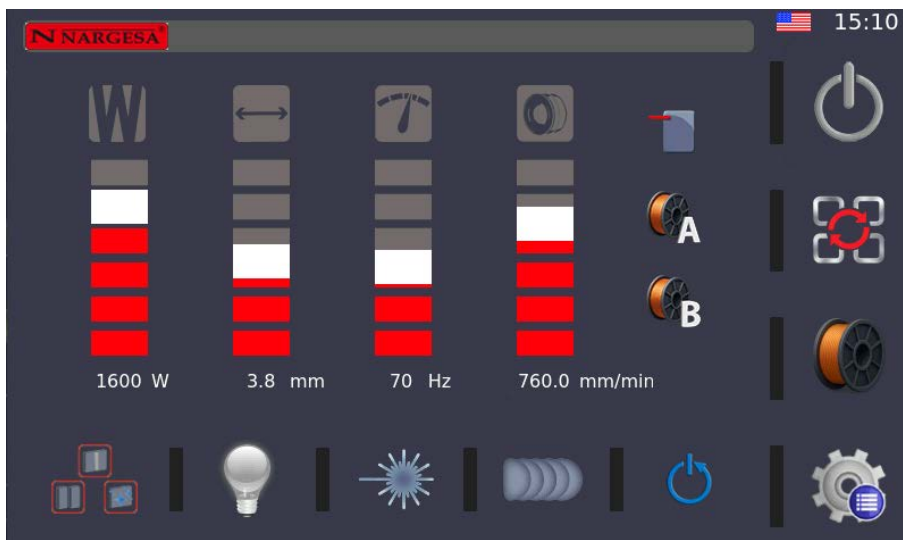

In the same way as in the cut mode, you have to configure the desired parameters. Press  and this menu appears.

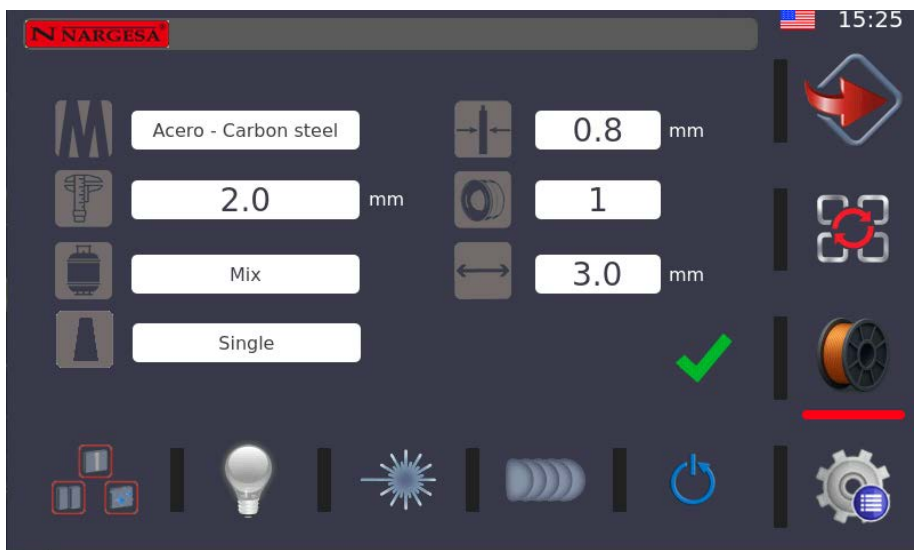

The control makes it possible to select the material to be welded, the thickness, the type of gas, the type of nozzle, the diameter of the filler wire, the number of filler wires and the width of the weld.

### 1. Material

o Press Material  to select the type of material to cut.

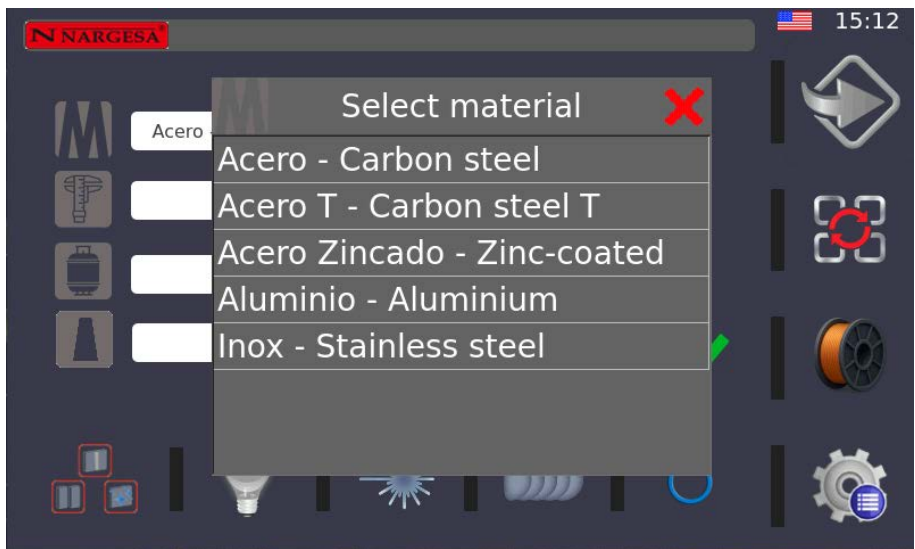

## 2. Thickness

- o Press Thickness  and choose the value corresponding to the material.



## 3. Gas

- Press Gas  and select the gas to be used: Nitrogen, Gas Mix or Argon.

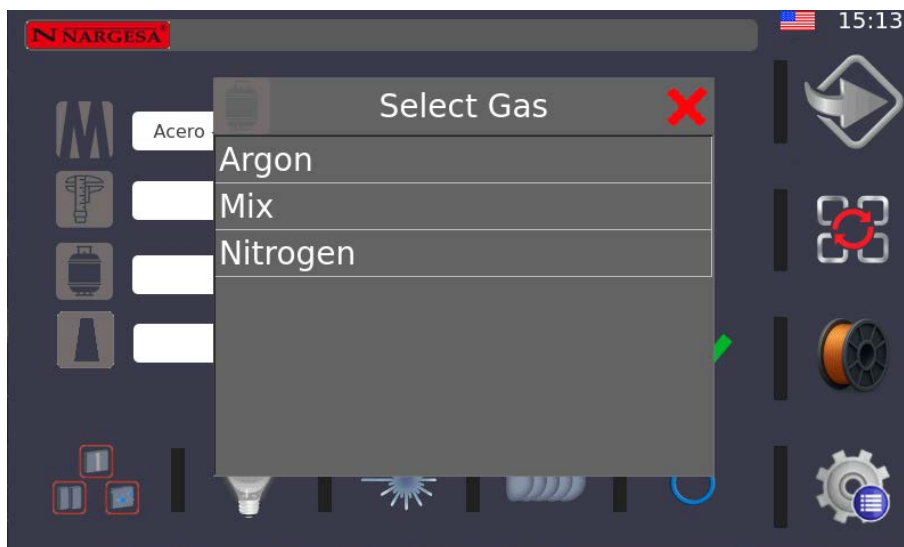

Gas recommendations:

- Nitrogen (N<sub>2</sub>)

Nitrogen is the most common option because of its low cost and because it favors good thermal management during the process.

It provides effective protection against oxidation on most metals and helps to maintain a stable molten bath temperature.

It is particularly suitable for stainless steels and carbon steels, offering a balance between quality and performance.

Typical operating pressure is between 2 and 7 bar, depending on the application and configuration.

- Argon (Ar)

Argon is especially recommended for welding aluminum and its alloys, due to its high purity and its completely inert character.

It provides superior rust protection, a more stable arc and top quality bead finishes.

The cost is higher, but it is ideal for jobs that require a perfect surface appearance or minimal thermal stress.

Usual operating pressure: 3 to 6 bar.

- Gas Mix (82% Argon + 18% CO<sub>2</sub>)

Gas Mix combines the advantages of Argon and Carbon Dioxide, offering a more economical alternative to pure Argon without overly compromising the quality of the finish.

This mixture (82% Ar + 18% CO<sub>2</sub>) provides good penetration, excellent arc stability and a uniform bead; it is particularly suitable for carbon steels and structural steels.

CO<sub>2</sub> promotes heat transfer and bead moisture, while Argon maintains molten bath protection.

The recommended operating pressure is between 3 and 7 bar.

Other commercially available mixtures can be used, but the 82% Ar + 18% CO<sub>2</sub> ratio is recommended as the standard configuration.

#### 4. Nozzle

- Press  to select the nozzle type compatible with the laser head.

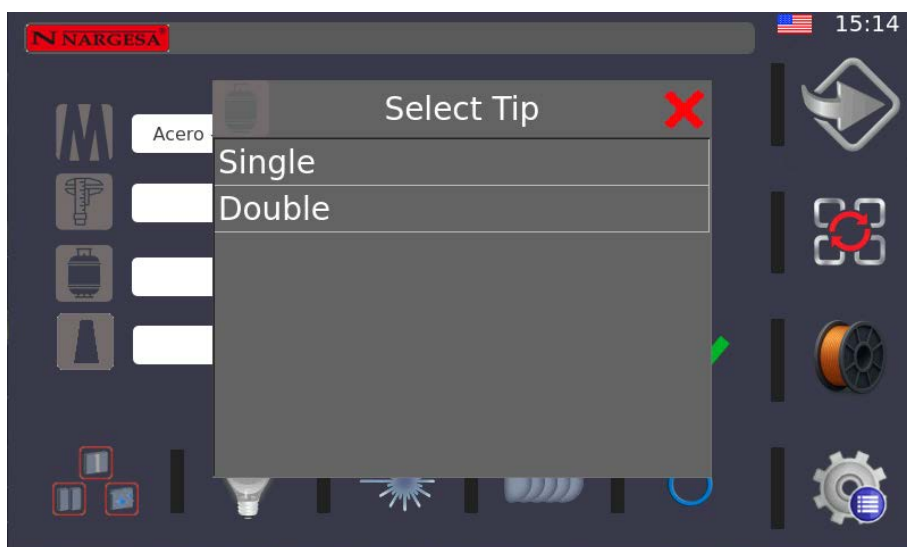

In this section you must select whether the welding nozzle is single or double.

This will allow the CNC to decide what the maximum and minimum bead width is; the laser may destroy the nozzle if you do not select the correct nozzle.

**5. Diameter of the filler wire**

- Press  to choose the filler wire diameter

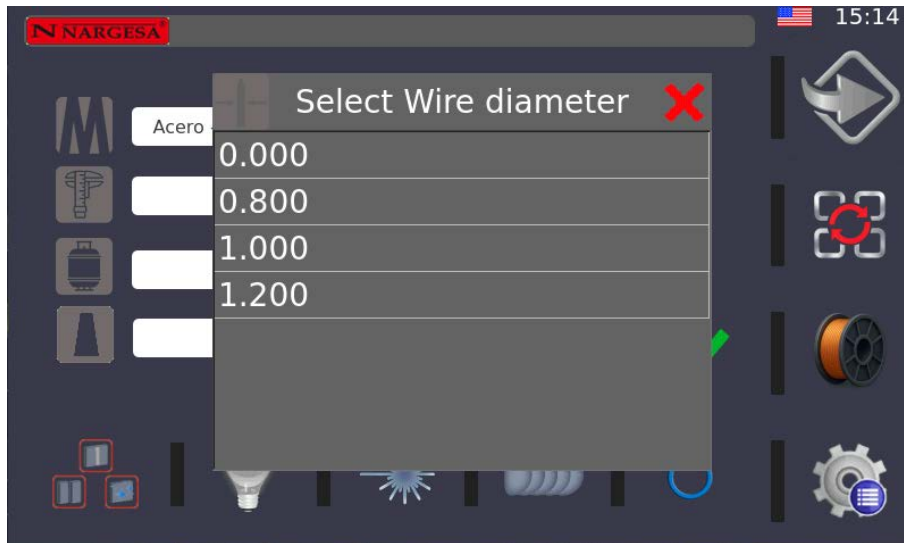

You can now choose the wire diameter or welding without filler wire; if you choose 0.0, the CNC will understand that there is no filler wire.

**6. Number of filler wires**

- Press  to choose the number of filler wires

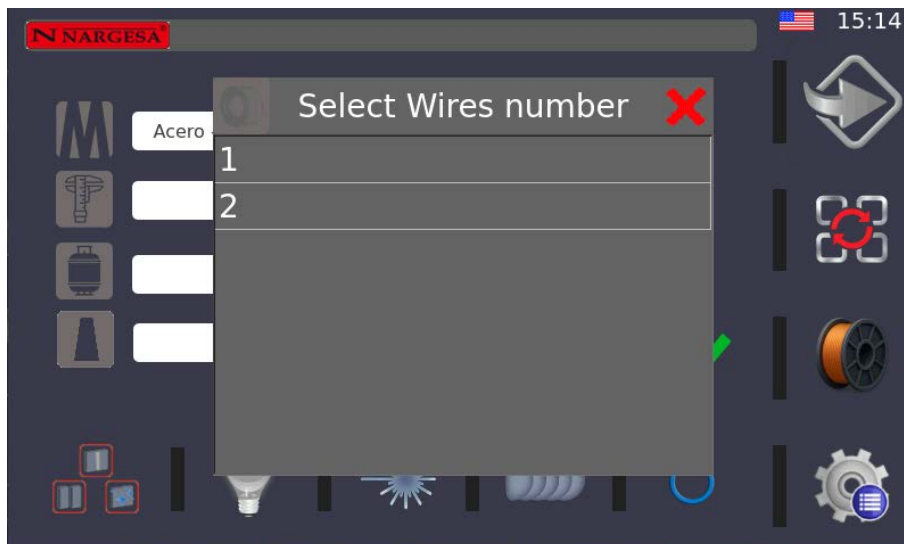

### 7. Weld width

• Press  to select the weld width

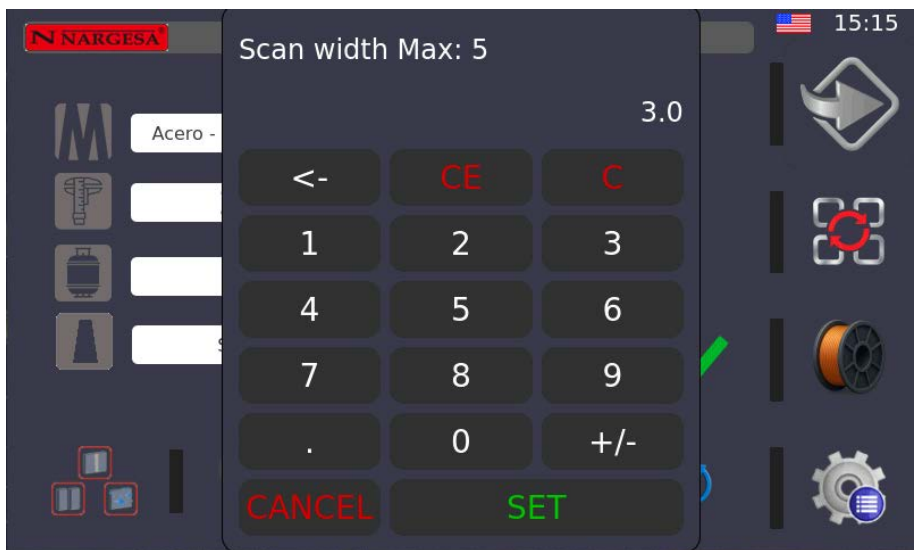

Any time a parameter conflicts with another parameter, the CNC highlights these fields in red.

After this, press  and the CNC will load the parameters to be able to perform the welding.

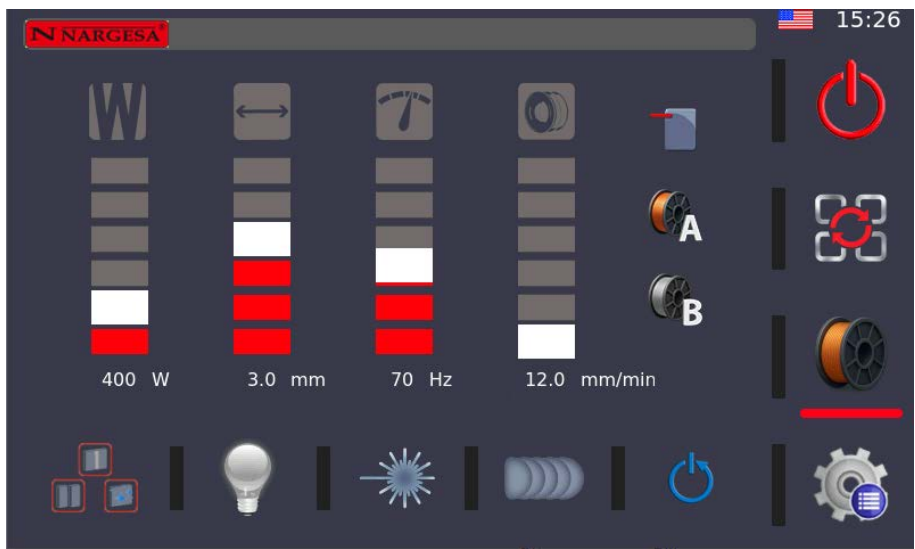





Then simply press  and the CNC will display an image like this:

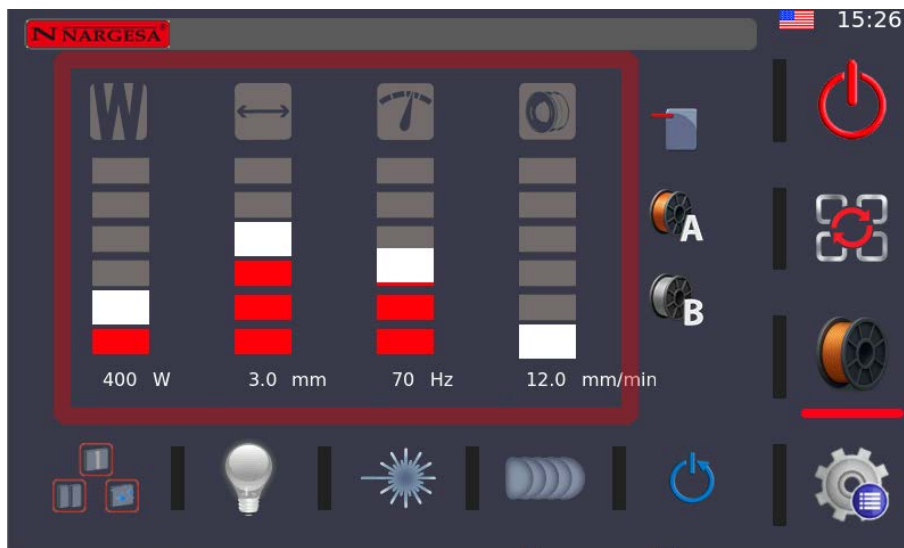

It should be noted that the MS20 is prepared for soldering: the safety unit has to be connected and all external security measures must be in place.





Each column has a level bar and the numerical value below it:

-  400 W      Laser power
-  3.0 mm      Width or swing in mm or inches
-  70 Hz      Weaving frequency of the beam/head
-  12.0 mm/min      Speed: welding feed or filler speed in mm or inches

The weld mode also has other menus.

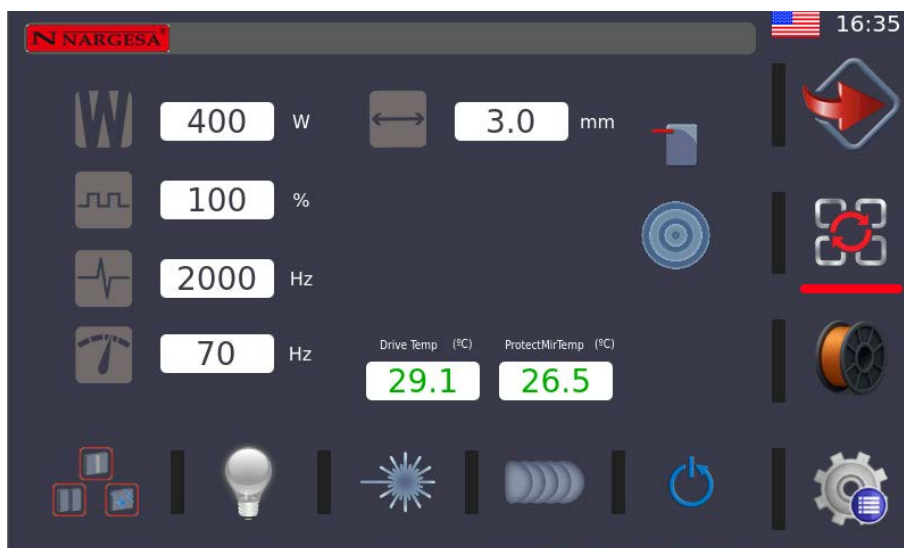
If you press this icon  the fine-tuning menu will appear.



Select the  icon. In this other menu you can also adjust the settings and verify the temperatures of the laser head. You can also verify what value you have loaded in the pulsed welding since these two parameters can only be verified from this page.

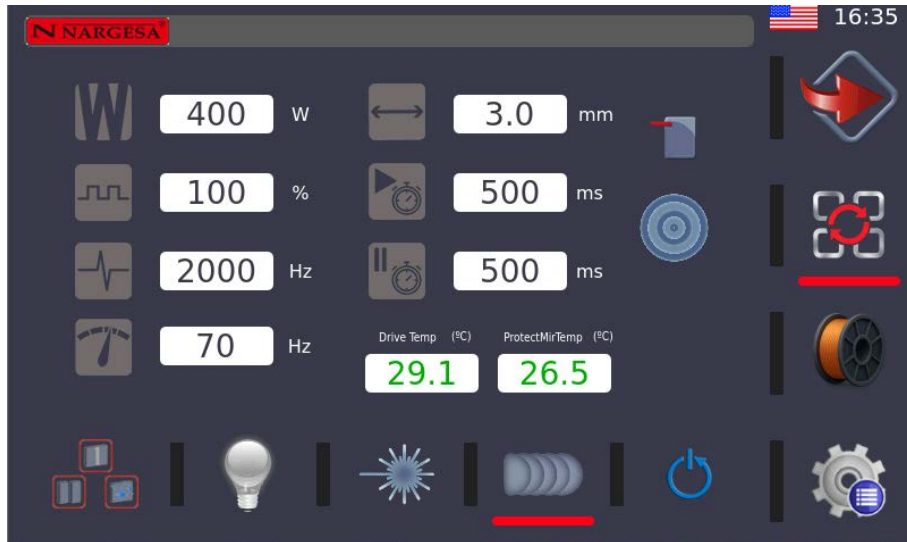

All these parameters are loaded into the MS20's internal Data Base parameters. If the operator wants to modify them, they can do so and save the new program.

## 8. Welding

Once all the parameters have been correctly configured, you verify that both the nozzle and the tip installed are suitable for the work to be carried out and that they match those selected in the parameter panel.

When these checks have been carried out, the equipment is ready to start the welding process.

To start welding, you will rest the nozzle on the plate maintaining an approximate inclination of 45°, with a margin of  $\pm 10^\circ$ .

For T-welding, you will need to tilt the head 45° vertically and 45° horizontally, thus ensuring a correct fusion of both surfaces.

Once the head is positioned, press the trigger to start cutting.

- Welding with filler: the operator only has to hold the welding head. The filler material will determine the feed rate throughout the bead.
- Welding without filler: the operator must manually move the welding head to form the bead, maintaining a constant and stable feed rate.



Throughout the process, the nozzle must remain in continuous contact with the workpiece.

### 9.3.1. Load welding wire

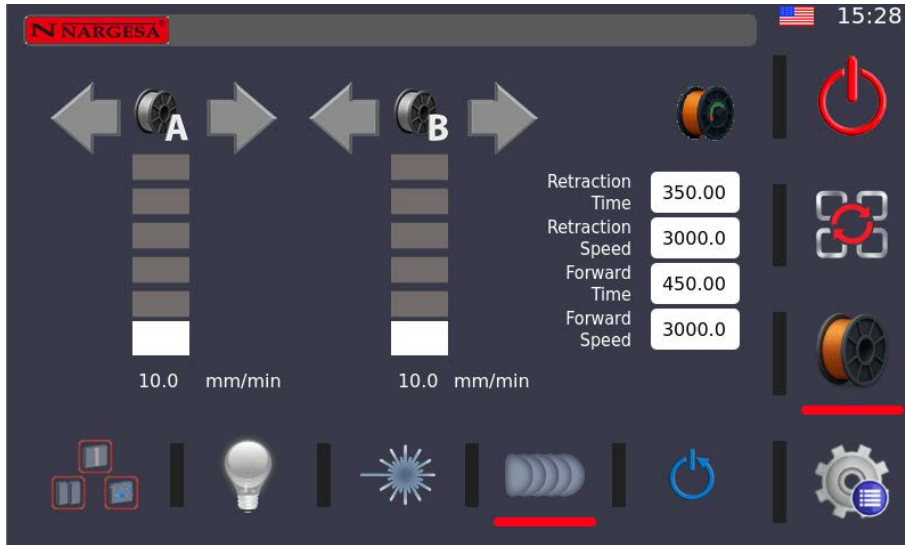
Within the weld mode, press the  icon to access the parameters for loading the welding wire.



#### 1. Feeder selection

- Two feeders are available: A and B  
- Pressing the icon of reel A or B activates or deactivates that feeder.
- The selected feeder will be used for both welding and wire loading.

#### 2. Normal wire load

- Once the feeder is selected, press the forward arrow  .
- The wire will move forward for loading.
- In this mode, the maximum wire speed is 1000 mm/min, which can be somewhat slow for the load.

#### 3. Fast wire loading

- If you need a faster loading, you can press the fast loading key of the feeder  .
- In this mode, the feeder reaches an extra speed of 5000 mm/min, which is enough to load the wire much faster.

In this same screen you can also **adjust the wire movement parameters after welding**. These are used to control how the wire behaves just when the bead ends, to prevent it from sticking to the workpiece or the nozzle.

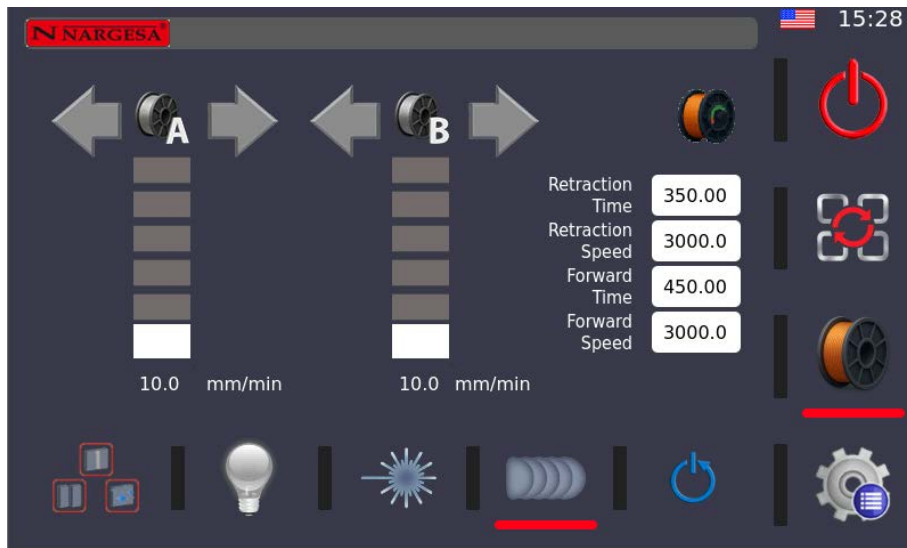

The parameters are:

#### 1. Retraction time

- It is the time the wire is moving backward at the end of the weld.
- The longer this time, the more wire is collected.
- It is used to slightly separate the wire from the molten bath and prevent it from sticking.

#### 2. Retraction speed

- It is the speed at which the wire retracts (mm/min).
- High speed removes the wire very quickly; low speed does it gentler.
- It is adjusted according to the type of material and the thickness: if it retracts too sharply it can generate pulls, if it is too slow it may not be effective.

#### 3. Feed time (after welding)

- This is the time that the wire advances forward after the weld is completed.
- It is used to keep the wire in a correct position for the next bead start, with the tip coming just out of the nozzle.

#### 4. Feed rate (after welding)

- It is the speed at which the wire advances during that final advance time.
- As before, it is measured in mm/min.
- It is used to adjust whether that final feed is smoother or faster, depending on the process and the welder's preferences.

### 9.4. Clean mode

To return to the start menu, press the  key.

Press  and the following screen will appear

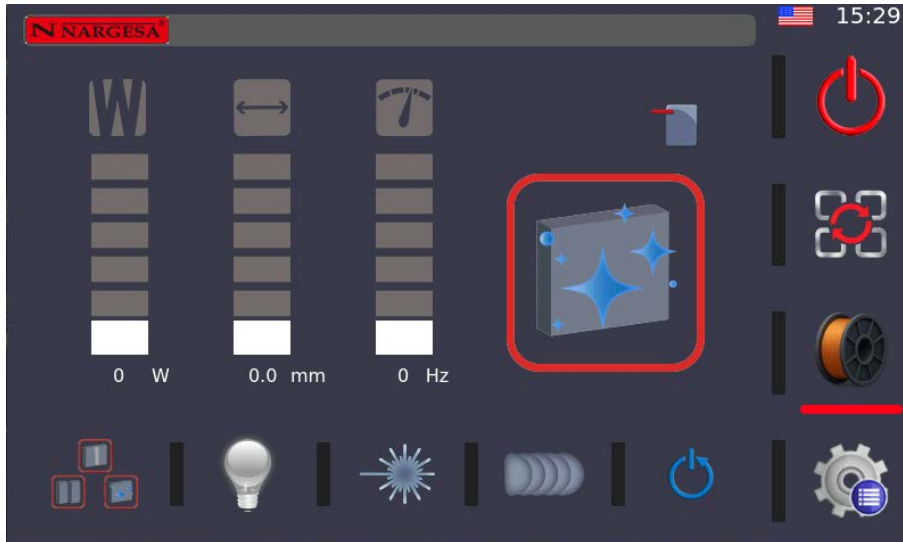

As in cut and weld mode, press this icon  and the following menu will appear

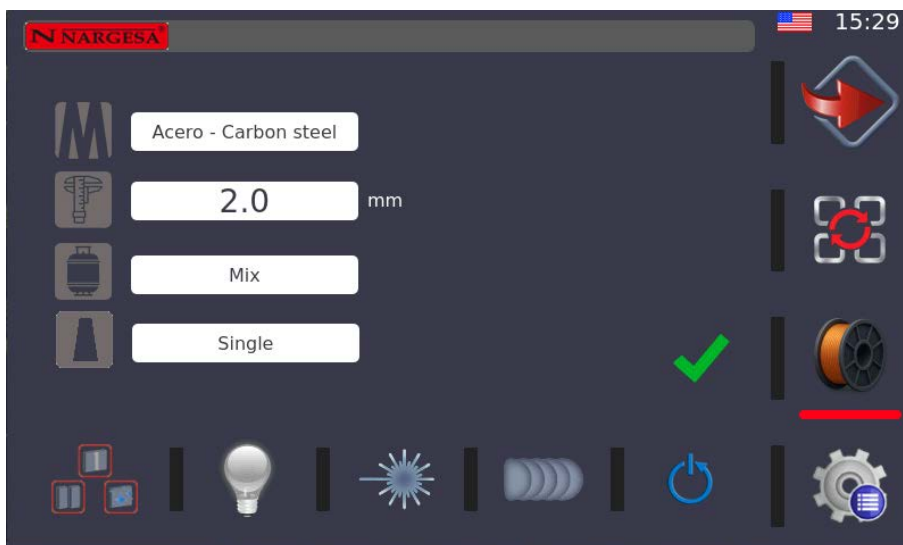

### 1. Material

Select the type of material to be cleaned 

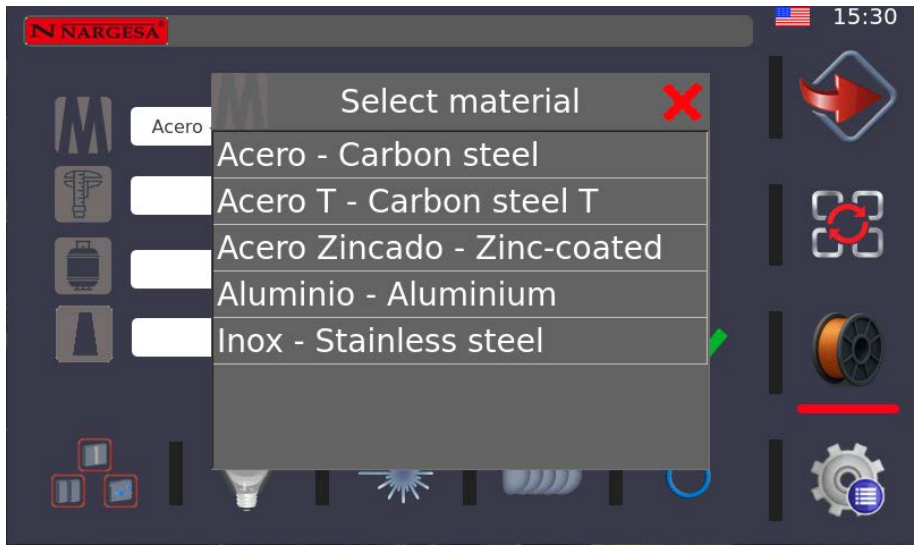

### 2. Thickness

Then you select the thickness of the material 

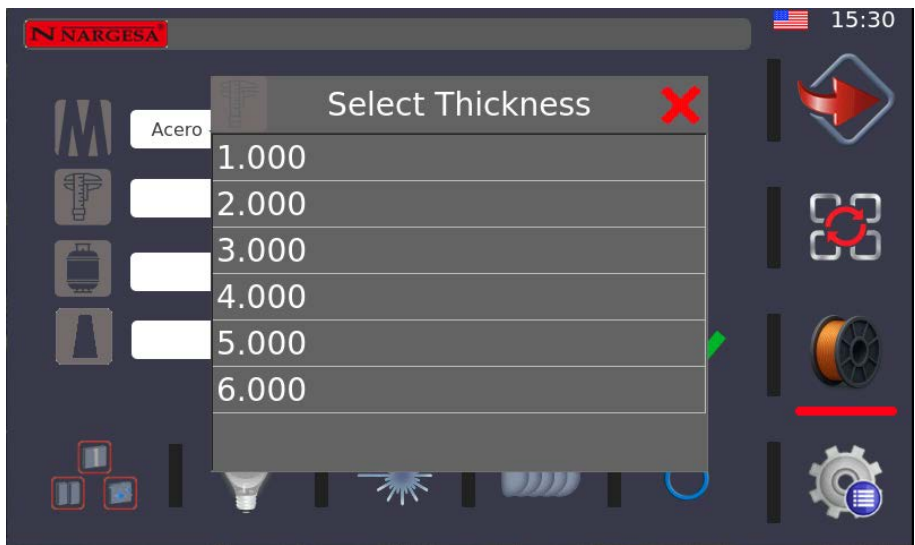

### 3. Gas

Next you select the type of gas  because the clean mode should only cool the gun. You can use any of the three gases, you could even use compressed air.

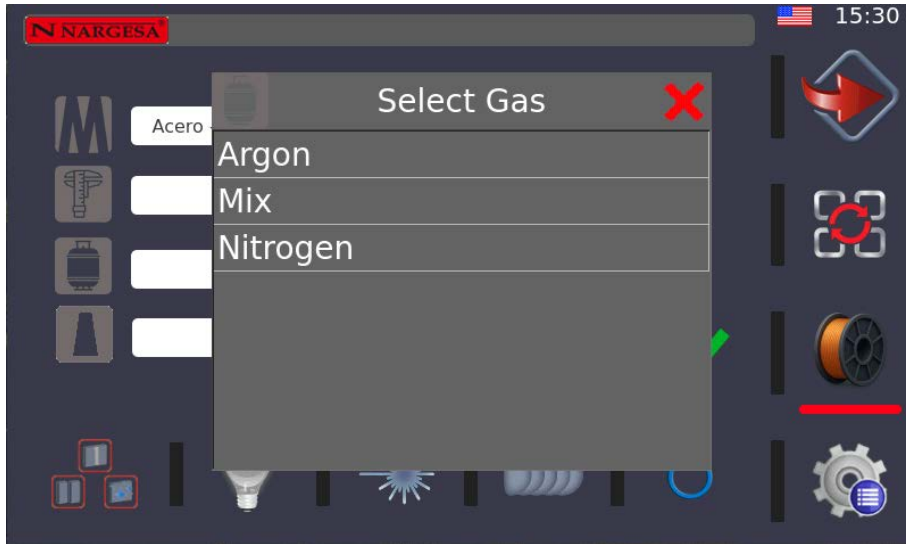

### 4. Nozzle

Select the nozzle you are going to use 

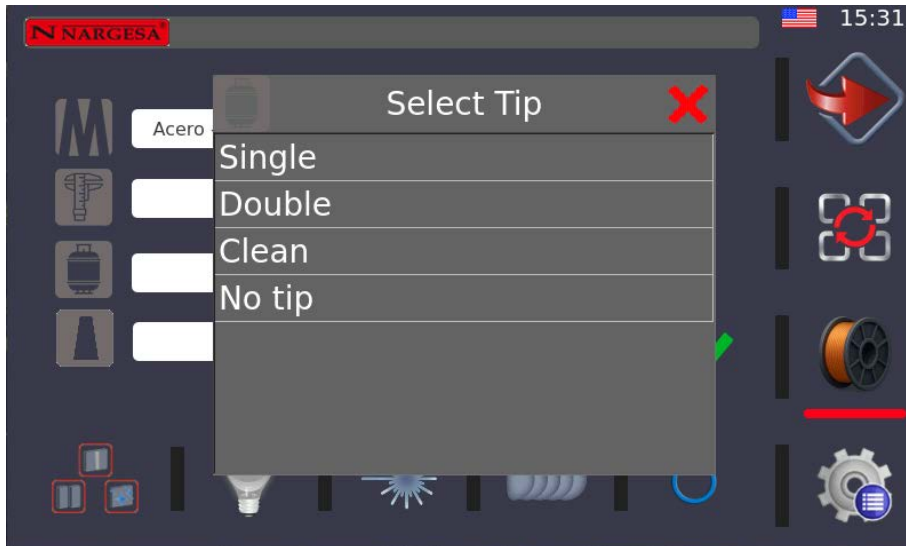

You can use any of the three nozzles available, but you must bear in mind that the single nozzle will open a maximum of 5 mm, the double nozzle 8 mm and the cleaning nozzle 18 mm. The CNC has a system which allows to remember which is the last installed nozzle and if it is not the correct one, the CNC will show an alarm to avoid burning the nozzle.

Press  and the CNC will load the parameters for cleaning.

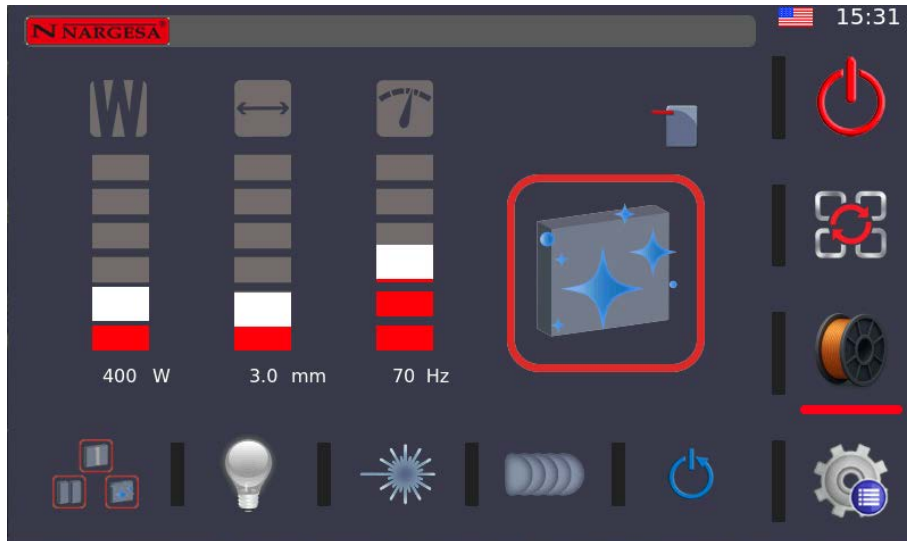

Then simply press  and the CNC will display an image like this one



It should be noted that the MS20 is set up for cleaning: the safety clamp must be connected and all external security measures have to be in place.

## 5. Cleaning

Once the parameters corresponding to the clean mode have been configured, you verify that the nozzle installed is suitable for the selected opening width and that it matches the option defined on the screen. With these checks completed, the equipment is ready to start the process.

To clean the bead, rest the nozzle on the surface of the sheet, maintaining a slope of approximately 45° all while allowing the beam to act uniformly on the area to be treated.

For T-joints, the head must be positioned with a slope of 45° vertically and 45° horizontally, ensuring that the beam correctly reaches both sides of the bead.

Once the head is in the right position, press the trigger to start cleaning.

During the process, the operator must manually move the head following the weld bead. The feed rate must be constant

and uniform to obtain a homogeneous result, avoiding overheated areas or insufficiently treated areas.

The nozzle must be kept in contact with the workpiece during the entire operation, as this ensures the correct focal length.

### 9.5. Saving programs

To save the program, in any of the three modes (cut, weld, clean) press 

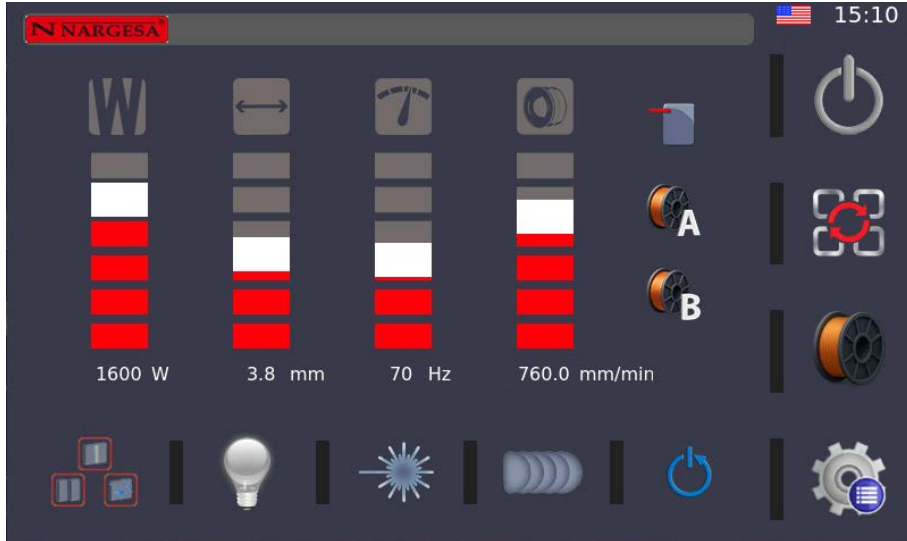

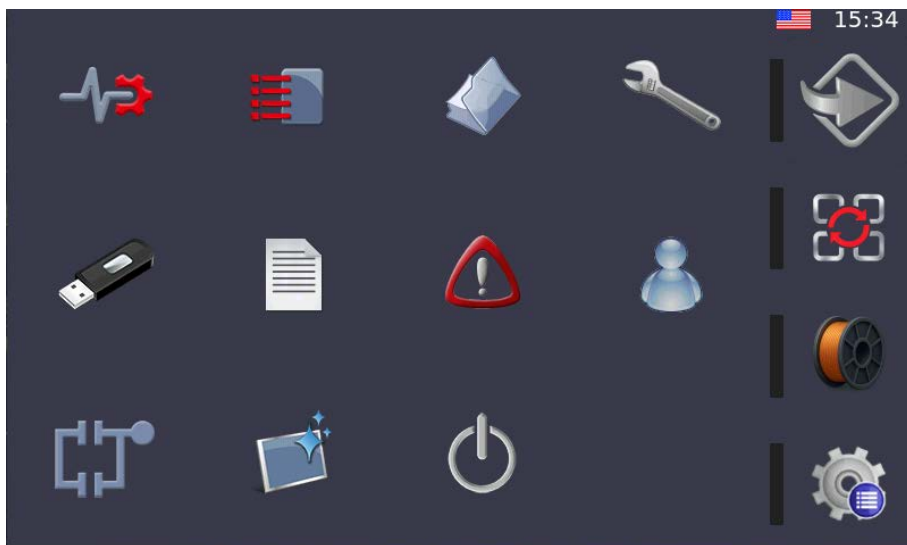

And this other screen will appear:

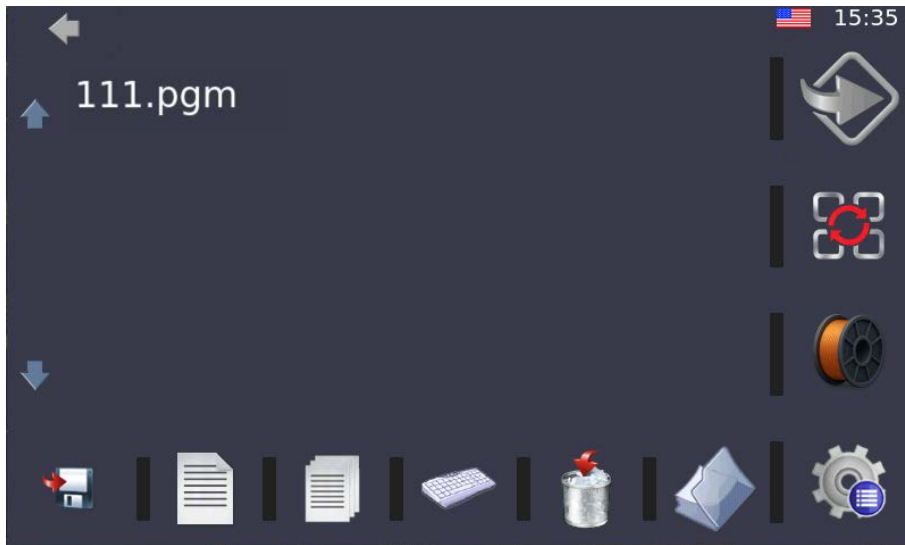

Press 

Now press  and the program will be saved automatically; you only have to enter the name and press Enter



To access the programs generated, go to the  icon and select the program you need by pressing the program name.



## 10. SETTINGS

For correct operation of the welder, it must be properly adjusted.

These settings are:

- **Laser centering.** Do a visual check of the laser centering on a daily basis. Do the complete centering once a month or if the head suffers a blow.
- **Focus adjustment.** Adjust the focus each time you change the nozzle.

### 10.1. Visual check of laser centering

To perform the visual inspection of the centering, you must have the beam width level bar  at 1 mm and activate the laser guide by pressing this icon .

To check it with filler, rest the nozzle on the sheet as if you were going to weld and verify that the laser point is centered with respect to the filler wire.

To check this without filler, also place the weld head in the welding position with the nozzle resting on the plate and observe if the laser spot on the plate is centered in the nozzle hole.

Never look directly at the laser beam or point the laser head at the face or body, only at the spot reflected on the sheet metal. If the beam is not centered in either case, the laser centering adjustment instructions below should be followed.



### 10.2. Laser centering

Why is centering so important?

When the beam is not coaxial with the nozzle:

- The beam hits the internal walls → the nozzle burns or deforms.
- Loss of penetration/quality and head overheating.
- Shorter life of nozzles and protective optics.

Good centering guarantees cutting/welding quality, lower consumable consumption and process stability.

From any of the three modes (cut, weld or clean), press this icon  and the fine-tuning page will appear. When you are on this page, you must press 

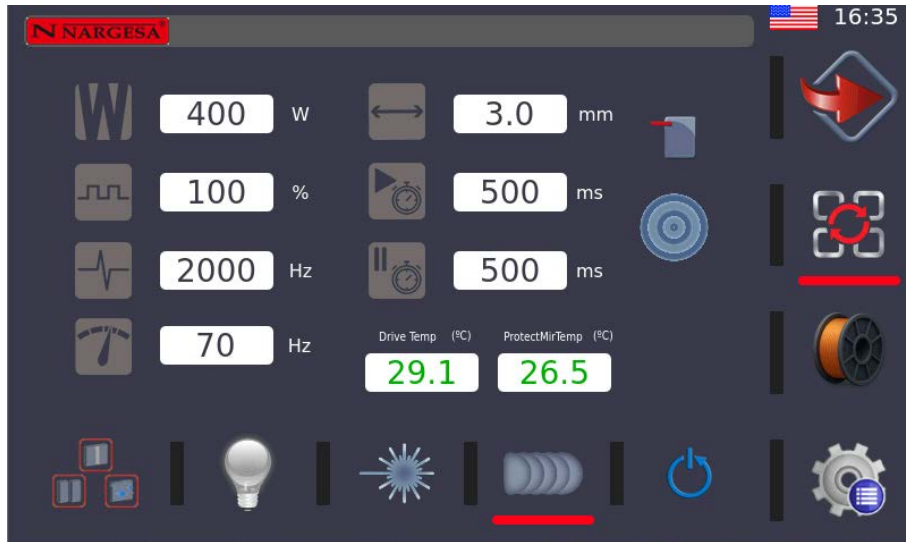



This page will open. Enter code: **Nargesa**.



Pressing Enter will display this screen:



In this screen, the two centering knobs adjust the beam offset with respect to the nozzle in small steps:

-  shifts the point to the left.
-  shifts the point to the right.

Each keystroke applies a small increment; keep it pressed down for continuous movement.



Preparation for laser centering:

1. Safety: Laser PPE, active guards and clear area.
2. Nozzle holder clean and straight.

3. Protective lens in good condition.

4. Place the tape with the center point on the nozzle holder, well adhered and without wrinkles. As shown in the picture:

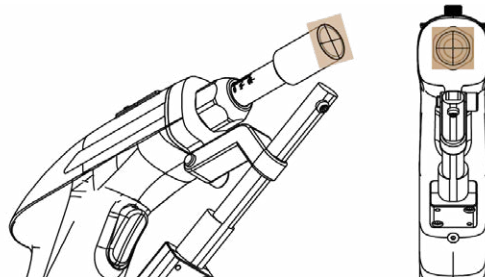

**First centering procedure. DOT IN TARGET method**

1. With the gas at 0.5 bar, press this icon . This screen appears:

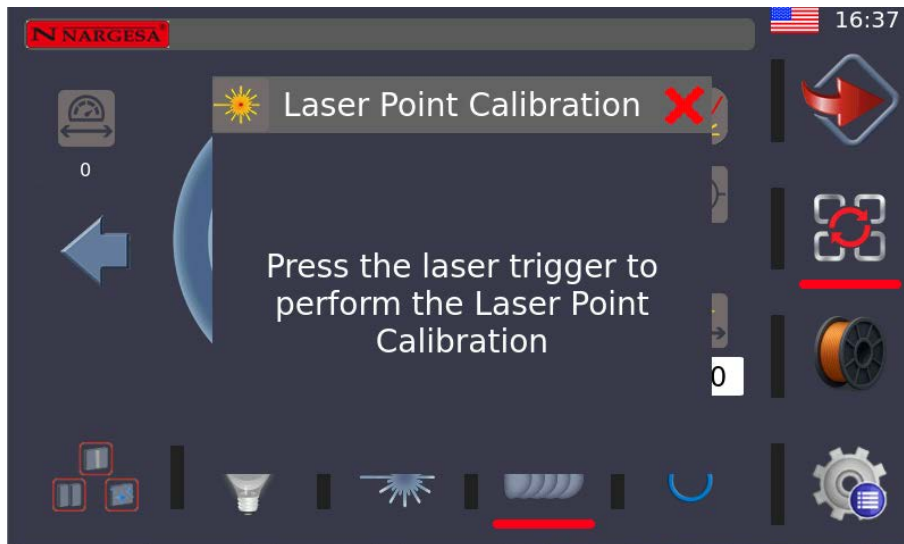

2. Connect all the safety mechanisms and do a short shot, making contact with the wire guide on the plate or on the table.



**WARNING: LASER ADJUSTMENT SHOT**

Before proceeding, make sure that there are no people, reflective materials or flammable objects in the work area.

A laser test is to be performed.

3. Observe the mark: it must coincide with the center point of the tape.

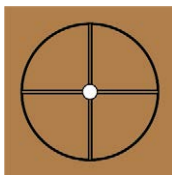

If the mark is offset, use the ← / → (offset) buttons to move the beam in the required direction.

Repeat the ☀️ → trigger → adjustment sequence until the mark is exactly over the center.

**Second centering procedure. LINE IN TARGET method**

1. Activate the gas at 0.5 bar and place a new tape with the central point on the nozzle holder, well-adhered and without any wrinkles.

2. Press this icon ☀️ .

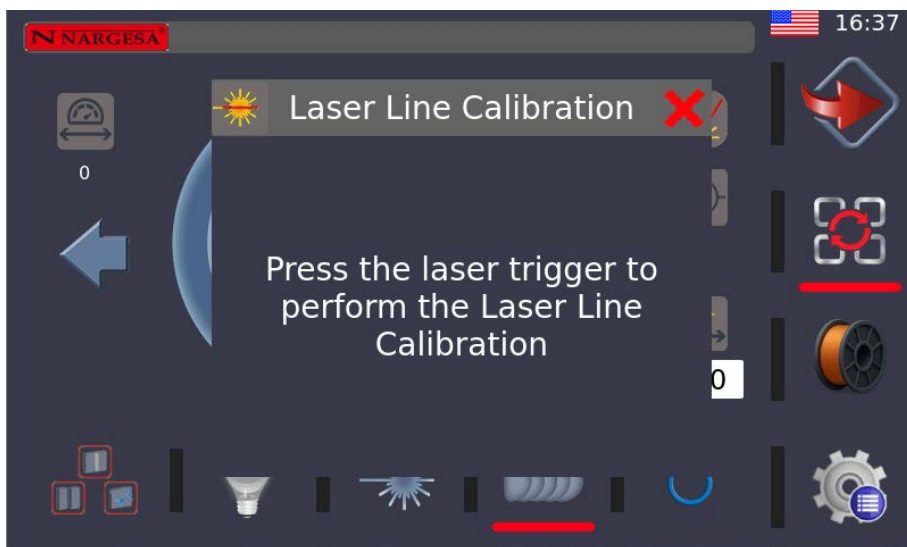

3. Connect all the safety mechanisms and do a short shot, making contact with the wire guide on the plate or on the table. Put on safety goggles before firing any shot.

**WARNING: LASER ADJUSTMENT SHOT**

Before proceeding, make sure that there are no people, reflective materials or flammable objects in the work area.

A laser test is to be performed.

4. Observe the mark: The line must be symmetrical with respect to the center point.

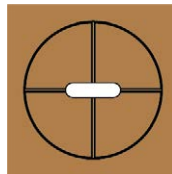



If the mark is offset, use the ← / → (offset) buttons to move the beam in the required direction.

Repeat the ☀ → trigger → adjustment sequence until the mark is exactly over the center.

**10.3. Focal point adjustment**

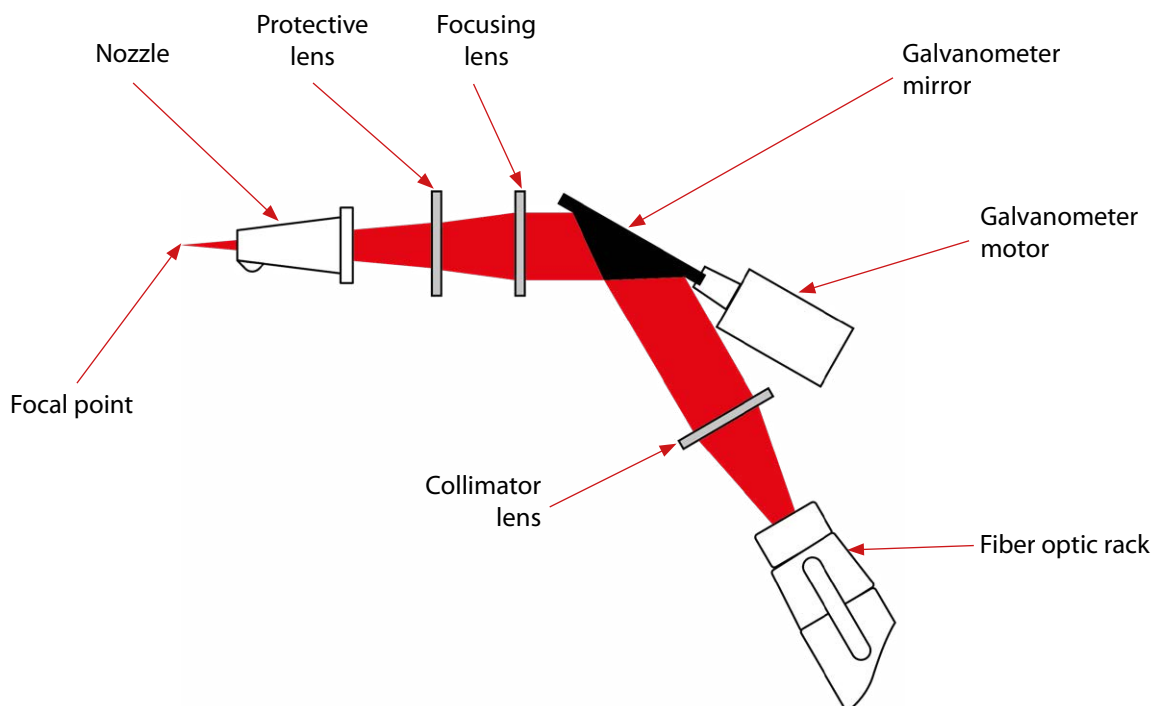
Calibrating the focal spot is essential to achieve correct laser penetration. When the focus is on the exact spot, the energy is concentrated in a minimum zone, reaching a higher temperature in a reduced area. This allows for precise melting or cutting. If the focus is slightly above or below the ideal point, the energy is dispersed and loses effectiveness, resulting in incomplete cuts, cold beads or poor fusion.



Once on this screen, press 



This screen will appear

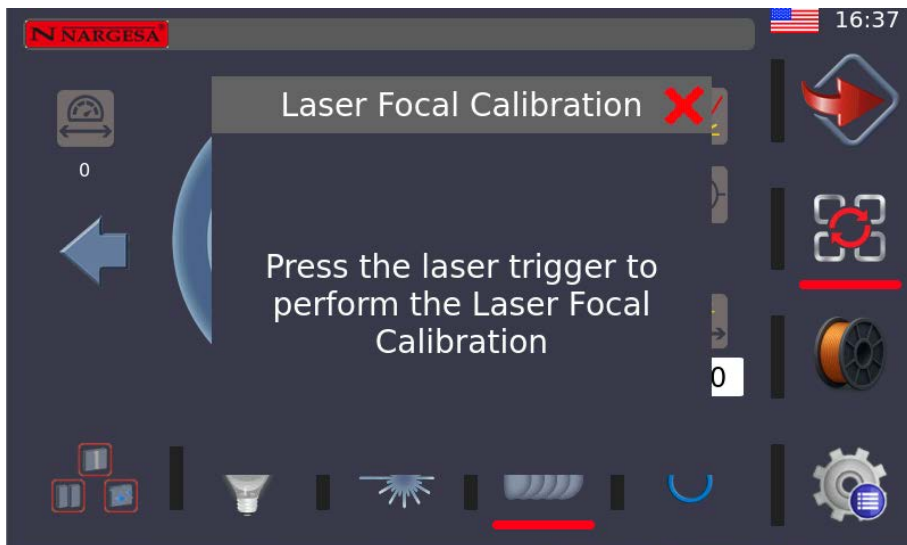

Material required for focal point adjustment:

- 3 mm aluminum sheet (0.12 in)
- Wrench for adjusting nozzle holder
- Safety glasses with an appropriate filter
- Heat resistant gloves
- Air or shielding gas (according to requirements)

### Preparation

Make sure the work area is clean and free of reflective materials.

Place the aluminum plate on the table.

Adjust the nozzle holder to position 10.

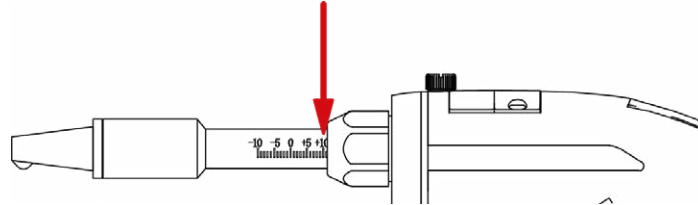

Install the nozzle and the wire feed you are going to use in the laser head.

Cut the wire just at the exit of the tip.

Verify that the system is correct and that the equipment is ready for a test shot.

Put on safety goggles and start firing, resting the nozzle on the plate and maintaining an inclination of approximately 45°, with a margin of  $\pm 10^\circ$ .



#### **WARNING: FOCAL POINT ADJUSTMENT SHOT**

Before proceeding, make sure that there are no people, reflective materials or flammable objects in the work area.

A laser test is to be performed.

### Procedure for focal point calibration

1. Make a first shot on the plate, with the plate holder in position 10. Observe the sparks generated.
2. Slightly loosen the nozzle holder nut.

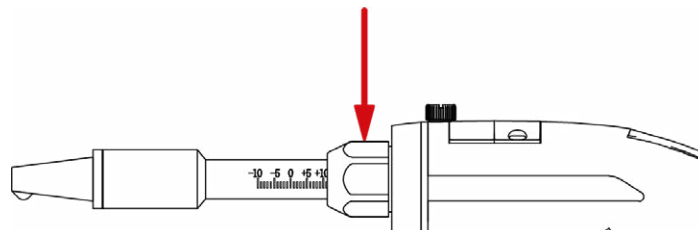

3. Move the bracket in a negative direction, in increments of 1 mm.

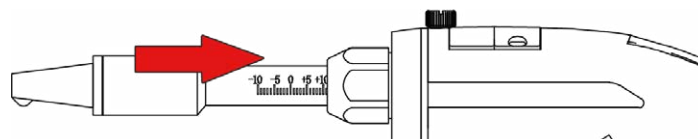

4. At each position, fire a new shot and observe the intensity of the sparks.
5. Identify the position where there are the most projections. That is the position of maximum energy and, therefore, the correct focal point.
6. Record the optimum focus position and retighten the bracket nut to secure it.

#### **Acceptance criteria**

- Abundant and long sparks: correct focus.
- Few or scattered sparks: focus out of position (too high or too low).
- Uniform and bright bead or melt mark: good calibration.

#### **Bead / cut geometry**

- o Well-calibrated focus = narrow, sharp bead.
- o Poorly calibrated focus = wide and flat bead (too unfocused above) or too deep and sharp with local over-penetration (too low).
- o Visually, a bad focus is noticeable because the thermally affected area looks very large and dirty.

Protect the mouthpiece and lens

- o If you are too close to the part, the spatter will get on the nozzle and even on the protective lens, damaging it and forcing us to replace it.

#### **Process speed**

- o With correct focus you can cut/weld faster while maintaining quality.
- o With bad focus you have to slow down to compensate.

#### **Repeatability and standard setup**

- o Once you have the optimal focal position, you can always return to it from scratch.
- o This means that different shifts / different operators achieve the same quality.

#### **Avoid rework**

- o A poorly calibrated focus generates lack of fusion, large pores and burrs and incomplete cuts.
- o This requires grinding, re-beading or re-cutting.
- o Reworking reheats the material and can deform thin parts.

#### **Thickness/material adjustment**

- o The ideal focal point is NOT the same for everything.
  - For laser cutting, it is often focused slightly below the surface on thick materials to foster the evacuation of the molten material. In other words, as soon as you have the correct focus setting, it will give between 1 and 2 mm in the negative direction.
  - For welding, the focus is usually placed right at the interface where you want the fusion.
- o That's why every time you change material, thickness, nozzle or even change the lens, you have to double check.

## 11. ERROR MANAGEMENT

Code	Description	Explanation
PLC 0	Emergency Stop	The emergency button or a safety circuit has been activated. The equipment is locked until it is manually reset.
PLC 1	Safety PLC not OK	Failure in the safety control system (safety PLC). The device does not allow the laser to be started due to protection.
PLC 2	Gas pressure alarm	Shielding gas pressure outside the established ranges. Check the input pressure and for any leaks.
PLC 3	Chiller alarm	Problem in the refrigeration system (chiller). It may be due to high temperature, low flow or general failure.
PLC 4	Laser head alarm	The head detects malfunction: it can be the driver temperature, lens temperature or a sensor failure.
PLC 5	Laser generator in alarm	The laser resonator has registered an internal error. Check the specific failure log for the generator.
PLC 6	Serial communication error	Loss of communication with the PLC. Check communication connections.

Symptoms / How to recognize it	Main cause	Solution / Recommended action
<b>Black burn marks on the surface of the glass. If there are burn marks scattered across the lens, it is almost certainly a slag burn.</b>	Slag splashes from the return flow hitting the glass, especially with double wire feed and high power.	Control slag: slightly defocus to reduce sparks; reduce power; optimize process parameters; improve splash protection; replace glass when damaged.
<b>White burn spots on the lens, not necessarily associated with a lot of visible slag.</b>	Defect in the glass itself (quality, internal stresses), incorrect assembly, insufficient cooling, or fatigue.	Replace the lens with a higher quality one; check the mounting and seal; check cooling/gas purge; establish periodic inspections and control the useful life of the glass.
<b>Glass severely damaged in a short time; numerous burn marks that are difficult to control.</b>	Very aggressive process: double wire feed and high power, generating a large amount of return slag.	Adjust the process: reduce power if possible, optimize speed/position, assess whether double threading is necessary or adjust its parameters, increase the frequency of changing the protective glass.

## 12. PROBLEMS WITH THE WELDING PROCESS

### 12.1. Material projections

Probable causes	Corrective actions
<ul style="list-style-type: none"> <li>Contaminated or damaged optics/nozzle → uneven power distribution and turbulent shielding gas.</li> <li>Improperly selected gas flow (insufficient or too high).</li> </ul>	<ul style="list-style-type: none"> <li>Change lenses or mouthpiece.</li> <li>Progressively increase the gas flow rate.</li> </ul>

### 12.2. Side bite

Probable causes	Corrective actions
<ul style="list-style-type: none"> <li>Beam-nozzle misalignment; deformed nozzle → poor gas coverage at the edges.</li> <li>Too much power or too little speed.</li> </ul>	<ul style="list-style-type: none"> <li>Refocus the laser beam (red pointer) and replace the damaged nozzle.</li> <li>Reduce speed and/or apply transverse oscillation to balance heat input.</li> </ul>

### 12.3 Bead collapse (subsidence)

Probable causes	Corrective actions
<ul style="list-style-type: none"> <li>Excessive energy.</li> <li>Low speed.</li> </ul>	<ul style="list-style-type: none"> <li>Reduce power and/or use positive defocus (broaden the spot to spread energy).</li> <li>Increase the speed</li> <li>Check the flow/temperature of the cooling circuit and the condition of the thermal system.</li> </ul>

### 12.4. Porosity

Probable causes	Corrective actions
<ul style="list-style-type: none"> <li>Poor shielding gas (low or turbulent flow), damaged nozzle.</li> <li>Contamination of the part (oils, oxides).</li> <li>Incorrect gas selection</li> </ul>	<ul style="list-style-type: none"> <li>High purity gas (<math>\geq 99.99\%</math>) and stable flow rate for the thickness; clean or new nozzle.</li> <li>Pre-cleaning (acetone type solvent / wire brush).</li> </ul>

### 12.5. Cracks (hot / cold)

Probable causes	Corrective actions
<ul style="list-style-type: none"> <li>• Hot crack: solidification with high stresses</li> <li>• Cold crack: rapid post-weld quenching and martensite-prone materials (carbon steels).</li> </ul>	<ul style="list-style-type: none"> <li>• Reduce effective heat (pulsed, stranded beads) to minimize stresses.</li> <li>• Preheat (150-300°C in steels with high hardenability) and cool slowly.</li> </ul>

### 12.6. Lack of fusion / lack of penetration

Probable causes	Corrective actions
<ul style="list-style-type: none"> <li>• Insufficient power or excessive defocusing (energy too dispersed).</li> <li>• Too high speed, especially in butt joint with side dissipation.</li> </ul>	<ul style="list-style-type: none"> <li>• Increase power and/or re-adjust the focus and slightly misalign it negatively to concentrate the energy inside the part.</li> <li>• Reduce speed</li> </ul>

### 12.7. Part deformation

Probable causes	Corrective actions
<ul style="list-style-type: none"> <li>• Linear excess heat in thin sheets (0.5-1.0 mm).</li> </ul>	<ul style="list-style-type: none"> <li>• For thin film, use low power (300-500 W), high speed and gentle positive defocusing.</li> </ul>

### 12.8. Material considerations

#### 12.8.1. Carbon steel

Key risks	Process keys
Oxidation/slag and cold crack with rapid cooling.	Protect with sufficient gas; evaluate preheating in high-hardenability steels; average parameters in 1-3 mm: 600-1200 W, 0.6-2 m/min, 0 or slight negative defocus.

### 12.8.2. Stainless steel

Key risks	Process keys
High reflectivity, splashed if gas is turbulent; bite sensitivity.	Slightly lower power than carbon steel for the same thickness; control the beam angle in corners; gauge joints often require 10-20% more energy than overlap due to bilateral dispersion with the same thickness.

### 12.8.3. Aluminum alloys

Key risks	Process keys
Very high reflectivity, oxide/hydrogen porosity, higher power requirement.	Mechanical-chemical pre-cleaning (rust), higher power for equal penetration; higher gas flows; in 3-5 mm, use 1500-2000 W, negative defocus (-2 to -3 mm) and oscillation to expand the bath.

## 13. MAINTENANCE

Proper maintenance of the MS20 laser welding equipment is essential to ensure its safe and efficient operation and to extend the life of all its components. Since the system integrates optical, electronic, mechanical and cooling elements, it is essential to follow a systematic maintenance program that includes preventive, predictive and corrective tasks.

All personnel in charge of these tasks must be duly trained and authorized, always following the instructions indicated in this manual, as well as the applicable safety standards.

Proper maintenance not only prevents costly breakdowns, but also ensures consistent weld quality, reduces the risk of unexpected failures and contributes to compliance with industrial safety regulations.

### 13. 1. Preventive maintenance

Mechanism	Task	Recommended frequency
Chiller (Water cooling)	- Check distilled water level - Verify water quality	Weekly
Chiller (Distilled water cooling)	- Completely replace the distilled water in the reservoir	Yearly
Laser head	- Verify beam alignment - Inspect the physical condition of the nozzle and the nozzle tip - Inspect the protective and focusing lenses	Daily
Wire feed system (Feeder)	- Clean drag rollers - Check for any wear	Monthly/ Roller change
Gas system	- Check flowmeters - Inspect for any leaks in connections	Weekly
Electrical system and PLC	- Check the connections - Clean dust from the control cabinet	Quarterly
Hoses and cables	- Inspect for wear, cuts, leaks or bending	Monthly
Cooling air filters	- Clean with pressurized air or replace filters	Every three months Depending on the environment and use
Check side protections	- Check the correct fastening of the covers to ensure they work	Monthly

## 13. 2. Predictive maintenance

Mechanism	Task	Method/ Indicator	Recommended frequency
Chiller	"Monitor temperature and flow"	"Check temperature and alarms of chiller on display / listen for changes in pump sound"	Weekly
Laser source	Check power stability	"Review internal alarm history and power variations on the control panel / Bluetooth diagnostics"	Monthly
Laser head	"Check for contamination of the protective lens"	"Visual inspection with direct illumination and slight tilt of the lens to detect halos, spots or smoke"	Daily
Feeder	Check for progressive roller wear	Check for any vibrations, skips or loss of drag during welding / check roll grooves	Every two weeks
Gas system	"Check flow and pressure stability"	"Check flowmeters and pressure constancy during operation"	Weekly
"Cooling hoses"	"Look for any microleakage or moisture in fittings"	Visual and tactile inspection	Monthly
Electrical and PLC connections	"Check the condition of connectors, end fittings and signal cables"	"Ensure the absence of overheating, electrical noise or vibrations / light cleaning"	Quarterly

### 13.3. Corrective maintenance

Common malfunction	Check	Corrective action
Low gas pressure alarm	Check regulator, cylinder and gas circuits	Change cylinder if empty Change hoses or regulator if leaks occur
Chiller alarm	Check water level, circulating pump, temperature sensor	Refill coolant if necessary Replace pump or sensor if necessary
Wire feeder failure	Check for tension, conditions of the roller groove, motor operation	Adjust drive tension, replace rollers or motor
Loss of laser power	Check the conditions of the protective and focus lenses	Replace lenses if they are deteriorated, no matter how slight they may appear to be
PLC communication error	Check connections, cables and sources of electrical noise	Contact Nargesa technical service
Coolant leakage	Repair hoses, fittings or exchangers	Shut down equipment until repair
Lens protection burned	Smoke or spatter has entered through the adjustable nozzle holder up to the lens	Gradually increase the gas pressure and perform tests With more power you need more gas pressure
Focus lens burned out	Perforated protective lens	Change protective and focus lens

## 14. ACCESSORIES AND CONSUMABLES

### 14.1. Included accessories

The MS20 has a drawer built into the chassis, specially designed to store consumables, keys and accessories in a clean, safe and tidy manner.

The MS20 Welder is supplied as standard with these **accessories included**:

#### Laser head holder

---

**REF: 130-19-01-00018**

Ergonomic support for the laser welding head. Steel structure with technical plastic padding to protect the torch when at rest. Textured black finish designed for the MS20.

- **Safety and organization:** prevents head drops and damage to lens/nozzles.
- **Full protection:** anti-scratch, non-slip padded blocks.
- **Quick access:** cradle-shaped geometry for one-hand placement and removal.
- **Magnetic mounting:** fixation by magnet on frame/table for easy positioning in the workspace.

#### Laser Safety Glasses

---

**REF: 080-MSL-00021**

Laser welding safety glasses with a specific filter for 900–1100 nm wavelength range. Wraparound frame covers front and sides, lightweight and comfortable for extended use. Case included.

- **Eye protection** for the 900–1100 nm band (fiber laser).
- **High optical density (OD)** to minimize incidental exposure risk.
- **Wraparound design:** protects against direct/reflected radiation and fine particles.
- **Comfort:** curved temples and stable fit under visor or helmet.
- **Certified safety and marking:** compliant with Standard Technical Rules and the essential requirements according to Annex II of the PPE Regulation (EU) 2016/425, in accordance with EN 207:2017. Marking: 740–900 D LB6 + I LB7, 900–1100 D LB6 + IR LB7 LP S CE, indicating the protection levels against laser radiation in the specified spectral ranges.

### Triple Allen Key 2–2.5–3 mm

---



**REF: 080-MSL-00029**

Y-shaped triple Allen key with 2 / 2.5 / 3 mm tips. Ergonomic orange polymer body for a comfortable and secure grip.

### Phillips Precision Screwdriver

---



**REF: 080-MSL-00030**

Precision screwdriver with Phillips (PH) tip for fine electronic and light mechanical work. Blue/yellow dual-color handle with rotating cap for palm support and controlled turning. Magnetizable tip for easy screw placement.

### Double Open-End Wrench 17–21 mm

---



**REF: 120-19-01-00109**

Double open-end wrench with 17 mm and 21 mm jaws. Slim profile and flat body for reaching narrow areas (fittings, nozzle nuts, and connections). Black finish with high resistance to wear and corrosion.

### Double to Single Nozzle Adapter

---



**REF: 120-19-01-00091**

Nozzle adapter converting dual outlet to single for laser welding guns. Machined brass body with corrosion resistance.

Designed to simplify switching from dual to single feed.

### Protection Lens

---



**REF: 080-MSL-00332**

Protective lens for welding, cutting, and cleaning weld beads.

10 protective lenses are supplied with the MS20.

## Weld Seam Cleaning Graded Tube



**REF: 080-MSL-00430**  
Nozzle for cleaning weld seams







## Centering Tape



**REF: 080-MSL-00335**  
Tape for centering the laser beam











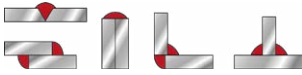

## Wire feed rollers

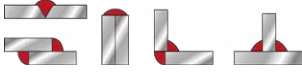
Wire feed rollers with double U-groove or V-groove, for different wire sizes and materials.  
4 rollers of each type are supplied.

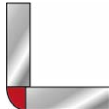
	Reference	Description	Wire Ø
	080-MSL-00326	Roller 0,8-1,0 U U-groove feed roller for aluminum wire.	0,8 and 1,0mm.
	080-MSL-00327	Roller 1.2-1.6 U U-groove feed roller for aluminum wire.	1,2 and 1,6mm.
	080-MSL-00328	Roller 1.6-2.0 U U-groove feed roller for aluminum wire.	1,6 and 2,0 mm.
	080-MSL-00329	Roller 0,8-1,0 V V-groove feed roller for steel wire.	0,8 and 1,0mm.
	080-MSL-00330	Roller 1,2-1,6 V V-groove feed roller for steel wire.	1,2 and 1,6 mm.
	080-MSL-00331	Roller 1,6-2,0 V V-groove feed roller for steel wire.	1,6 and 2,0 mm.

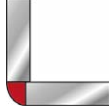
## Laser Welding Nozzles

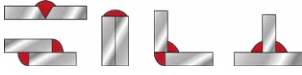
Laser welding nozzles with and without filler wire feed, for different welding applications.  
One nozzle of each type is supplied.

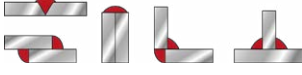
	Description	Wires	Type of welding	Wire Ø	Model
	Ref: 080-MSL-00413 Nozzle for autogenous welding, for outside corner welding.	-		-	C
	Ref: 080-MSL-00415 Nozzle for welding with filler wire up to 1.2 mm, for flat welding, inside corners and outside corners.	1		1.2 mm	AS-12
	Ref: 080-MSL-00416 Nozzle for welding with filler wire up to 1.6 mm, for flat welding, inside corners and outside corners.	1		1.6 mm	BS-16
	Ref: 080-MSL-00419 Nozzle for welding with filler wire up to 1.2 mm, for outside corner welding.	1		1.2 mm	CS-12
	Ref: 080-MSL-00431 Nozzle for welding with filler wire up to 1.6 mm, for outside corner welding.	1		1.6 mm	ES-16 FS-16
	Ref: 080-MSL-00425 Nozzle for welding with dual filler wire feed up to 1.2 mm, for flat welding, inside corners and outside corners.	2		1.2 mm	AS-12D
	Ref: 080-MSL-00427 Nozzle for welding with dual filler wire feed up to 2.0 mm, for flat welding, inside corners and outside corners.	2		2.0 mm	AS-20D

## Nozzle and tip for cutting









Nozzle and tip for laser cutting. One set is supplied, consisting of 1 nozzle and 1 tip.

	Description	Model
	Ref: 080-MSL-00428 Nozzle and tip set for sheet metal cutting.	CT-15

## Feed noozles

Wire feed guide noozles.

One noozle of each type is supplied.

	Ref.	Description	Wires	Ø
	080-MSL-00402	Double wire feed nozzle 1.0 mm Double wire feed guide nozzle, 1.0 mm.	2	1,0 mm.
	080-MSL-00403	Double wire feed nozzle 1.2 mm Double wire feed guide nozzle, 1.2 mm.	2	1,2 mm.
	080-MSL-00404	Double wire feed nozzle 1.6 mm Double wire feed guide nozzle, 1.6 mm.	2	1,6 mm.
	080-MSL-00405	Double wire feed nozzle 2.0 mm Double wire feed guide nozzle, 2.0 mm.	2	2,0 mm.
	080-MSL-00406	Single wire feed nozzle 0.8 mm Wire feed guide nozzle, 0.8 mm.	1	0,8 mm.
	080-MSL-00407	Single wire feed nozzle 1.0 mm Wire feed guide nozzle, 1.0 mm.	1	1,0 mm.
	080-MSL-00408	Single wire feed nozzle 1.2 mm Wire feed guide nozzle, 1.2 mm.	1	1,2 mm.
	080-MSL-00409	Single wire feed nozzle 1.6 mm Wire feed guide nozzle, 1.6 mm.	1	1,6 mm.
	080-MSL-00410	Single wire feed nozzle 2.0 mm Wire feed guide nozzle, 2.0 mm.	1	2,0 mm.

## 14.2. Optional accessories and consumables

### Electronic Laser Protection Mask

---

**REF: 080-MSL-00023**

Auto-darkening electronic helmet with adjustable sensitivity and solar-powered photosensor for laser work. Wraparound polymer shell with adjustable harness and specific front laser filter. Side control for shade adjustment. Designed to protect the operator's eyes and face during laser welding and marking operations, according to filter configuration.



- **Full eye and face protection** against laser radiation (per installed filter), sparks, and light projections.
- **Adjustable auto-darkening:** automatic shade change upon emission detection (response time and darkness level configurable).
- **Comfort for long use:** lightweight, balanced helmet with adjustable headgear (diameter, height, and depth) for superior comfort.
- **High visibility in standby:** light mode for positioning and part preparation with precision.
- **Certified safety and marking:** compliant with the Standard technical rules and the essential requirements of Annex II of PPE Regulation (EU) 2016/425 (EN ISO 16321-1:2022, EN ISO 16321-2:2021, ISO 16321-1:2021/Amd.1:2024, EN 207:2017). Marking: eye protection 16321 LP W4 1-M, 950-100 D LB7 IR LB8 LP CE; face and head protection 16321 LP W4 1-M, 900-1100 D LB5 IR LB8 LP CE; automatic welding filter 11961-PZA-24.

### Laser Protection Mask

---











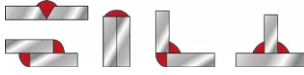

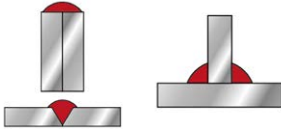

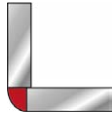

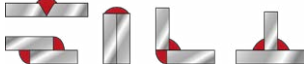

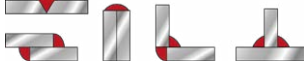

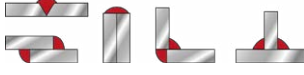

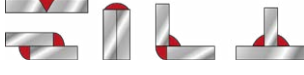
**REF: 080-MSL-00022**







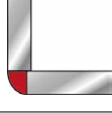

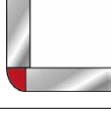

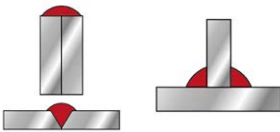
Passive laser welding mask with specific green laser visor. Lightweight wraparound helmet with adjustable headgear and side adjustment. Designed to protect the operator's eyes and face during manual laser welding and auxiliary operations against UV exposure.

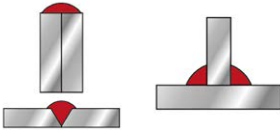

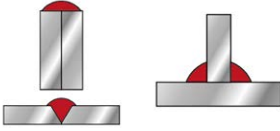
- **Eye and face protection** against laser radiation and light projections during welding.
- **Simplicity and reliability:** no electronics or batteries; minimal maintenance.
- **Comfort:** adjustable headgear for diameter, height, and depth.
- **Wide field of view** with large passive visor.
- **Certified safety and marking:** compliant with the essential requirements of Annex II of PPE Regulation (EU) 2016/425, in accordance with EN ISO 16321-2:2021 and EN 207:2017. Marking: eye protection 16321 LP W4 1-M, 950-100 D LB7 IR LB8 LP CE; face and head protection 16321 LP W4 1-M, 900-1100 D LB5 IR LB8 LP CE.

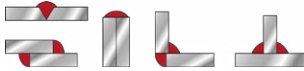

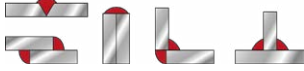
## Laser Welding Nozzles

	Description	Wires	Type of welding	Wire Ø	Model
	Ref: 080-MSL-00411 Nozzle for autogenous welding, for flat welds, inside corners and outside corners.	-		-	A
	Ref: 080-MSL-00412 Nozzle for autogenous welding, for flat welds or inside corners.	-		-	B
	Ref: 080-MSL-00413 Nozzle for autogenous welding, for outside corner welding.	-		-	C
	Ref: 080-MSL-00414 Nozzle for welding with filler wire up to 1.0 mm, for flat welding, inside corners and outside corners.	1		1.0 mm	AS-10
	Ref: 080-MSL-00415 Nozzle for welding with filler wire up to 1.2 mm, for flat welding, inside corners and outside corners.	1		1.2 mm	AS-12
	Ref: 080-MSL-00416 Nozzle for welding with filler wire up to 1.6 mm, for flat welding, inside corners and outside corners.	1		1.6 mm	BS-16
	Ref: 080-MSL-00417 Nozzle for welding with filler wire up to 2.0 mm, for flat welding, inside corners and outside corners.	1		2.0 mm	BS-20
	Ref: 080-MSL-00418 Nozzle for welding with filler wire up to 1.0 mm, for outside corner welding.	1		1.0 mm	CS-10
	Ref: 080-MSL-00419 Nozzle for welding with filler wire up to 1.2 mm, for outside corner welding.	1		1.2 mm	CS-12
	Ref: 080-MSL-00420 Nozzle for welding with filler wire up to 1.6 mm, for outside corner welding.	1		1.6 mm	CS-16
	Ref: 080-MSL-00421 Nozzle for welding with filler wire up to 1.2 mm, for outside corner welding.	1		1.2 mm	ES-12
	Ref: 080-MSL-00431 Nozzle for welding with filler wire up to 1.6 mm, for outside corner welding.	1		1.6 mm	ES-16 FS-16







	Description	Wires	Type of welding	Wire Ø	Model
	Ref: 080-MSL-00422 Nozzle for welding with filler wire up to 1.0 mm, for flat welding and inside corners.	1		1.0 mm	DS-10
	Ref: 080-MSL-00423 Nozzle for welding with filler wire up to 1.2 mm, for flat welding and inside corners.	1		1.2 mm	DS-12
	Ref: 080-MSL-00424 Nozzle for welding with filler wire up to 1.6 mm, for flat welding and inside corners.	1		1.6 mm	DS-16
	Ref: 080-MSL-00425 Nozzle for welding with dual filler wire feed up to 1.2 mm, for flat welding, inside corners and outside corners.	2		1.2 mm	AS-12D
	Ref: 080-MSL-00426 Nozzle for welding with dual filler wire feed up to 1.6 mm, for flat welding, inside corners and outside corners.	2		1.6 mm	AS-16D
	Ref: 080-MSL-00427 Nozzle for welding with dual filler wire feed up to 2.0 mm, for flat welding, inside corners and outside corners.	2		2.0 mm	AS-20D

### Nozzle and tip for cutting



Nozzle and tip for laser cutting. One set is supplied, consisting of 1 nozzle and 1 tip.

	Description	Model
	Ref: 080-MSL-00428 Nozzle and tip set for sheet metal cutting.	CT-15
	Ref: 080-MSL-00429 1.5 mm tip for the cutting nozzle.	CT-15

## Steel, Teflon and Graphite Liners







Description	
	Ref. 080-MSL-00301 Steel Liner Blue 0.6-0.8, 5m Welding liner for 0.6–0.8 mm steel wire, 5 m
	Ref. 080-MSL-00302 Steel Liner Red 1.0-1.2, 5m Welding liner for 1.0–1.2 mm steel wire, 5 m
	Ref. 080-MSL-00304 Teflon Liner Blue 0.6-0.8, 5m Welding liner for 0.6–0.8 mm aluminium wire, 5 m
	Ref. 080-MSL-00305 Teflon Liner Red 1.0-1.2, 5m Welding liner for 1.0–1.2 mm aluminium wire, 5 m
	Ref. 080-MSL-00306 Teflon Liner Yellow 1.4-1.6, 5m Welding liner for 1.4–1.6 mm aluminium wire, 5 m
	Ref. 080-MSL-00307 Graphite Liner 1.0-2.0, 5m Welding liner for 1.0–2.0 mm aluminium wire, 5 m
	Ref. 080-MSL-00308 Steel Liner 1.2-2.0, 5m Welding liner for 1.2–2.0 mm steel wire, 5 m

## Lenses

Description	
	Ref. 080-MSL-00323 Reflective Lens Reflective lens for welding, cutting and weld bead cleaning.
	Ref. 080-MSL-00321 Focusing Lens D20 × F150 × T3 Focusing lens D20 F150 for welding, cutting and weld bead cleaning.
	Ref. 080-MSL-00320 Collimating Lens D16 × F60 × T3 Collimating lens D16 for welding, cutting and weld bead cleaning.
	Ref. 080-MSL-00332 Protective Lens Protective lens for welding, cutting and weld bead cleaning.

## Feed rollers

Feed rollers with double "U" or "V" groove for different wire sizes and materials.

	Ref.	Description	Wires Ø
	080-MSL-00326	Roller 0.8–1.0 U U-groove feed roller for aluminum wire.	0,8 y 1,0mm.
	080-MSL-00327	Roller 1.2–1.6 U U-groove feed roller for aluminum wire.	1,2 y 1,6mm.
	080-MSL-00328	Roller 1.6–2.0 U U-groove feed roller for aluminum wire.	1,6 y 2,0 mm.
	080-MSL-00329	Roller 0.8–1.0 V V-groove feed roller for steel wire.	0,8 y 1,0mm.
	080-MSL-00330	Roller 1.2–1.6 V V-groove feed roller for steel wire.	1,2 y 1,6 mm.
	080-MSL-00331	Roller 1.6–2.0 V V-groove feed roller for steel wire.	1,6 y 2,0 mm.









## Graded Tube



**REF: 080-MSL-00334**  
Graduated focusing tube for nozzles.

## Feed noozles

Wire feed guide noozles.

	Ref.	Description	Wires	Ø
	080-MSL-00402	Double wire feed nozzle 1.0 mm Double wire feed guide nozzle, 1.0 mm.	2	1,0 mm.
	080-MSL-00403	Double wire feed nozzle 1.2 mm Double wire feed guide nozzle, 1.2 mm.	2	1,2 mm.
	080-MSL-00404	Double wire feed nozzle 1.6 mm Double wire feed guide nozzle, 1.6 mm.	2	1,6 mm.
	080-MSL-00405	Double wire feed nozzle 2.0 mm Double wire feed guide nozzle, 2.0 mm.	2	2,0 mm.
	080-MSL-00406	Single wire feed nozzle 0.8 mm Wire feed guide nozzle, 0.8 mm.	1	0,8 mm.
	080-MSL-00407	Single wire feed nozzle 1.0 mm Wire feed guide nozzle, 1.0 mm.	1	1,0 mm.
	080-MSL-00408	Single wire feed nozzle 1.2 mm Wire feed guide nozzle, 1.2 mm.	1	1,2 mm.
	080-MSL-00409	Single wire feed nozzle 1.6 mm Wire feed guide nozzle, 1.6 mm.	1	1,6 mm.
	080-MSL-00410	Single wire feed nozzle 2.0 mm Wire feed guide nozzle, 2.0 mm.	1	2,0 mm.



## TECHNICAL ANNEX

---

# Laser Welding Equipment MS20

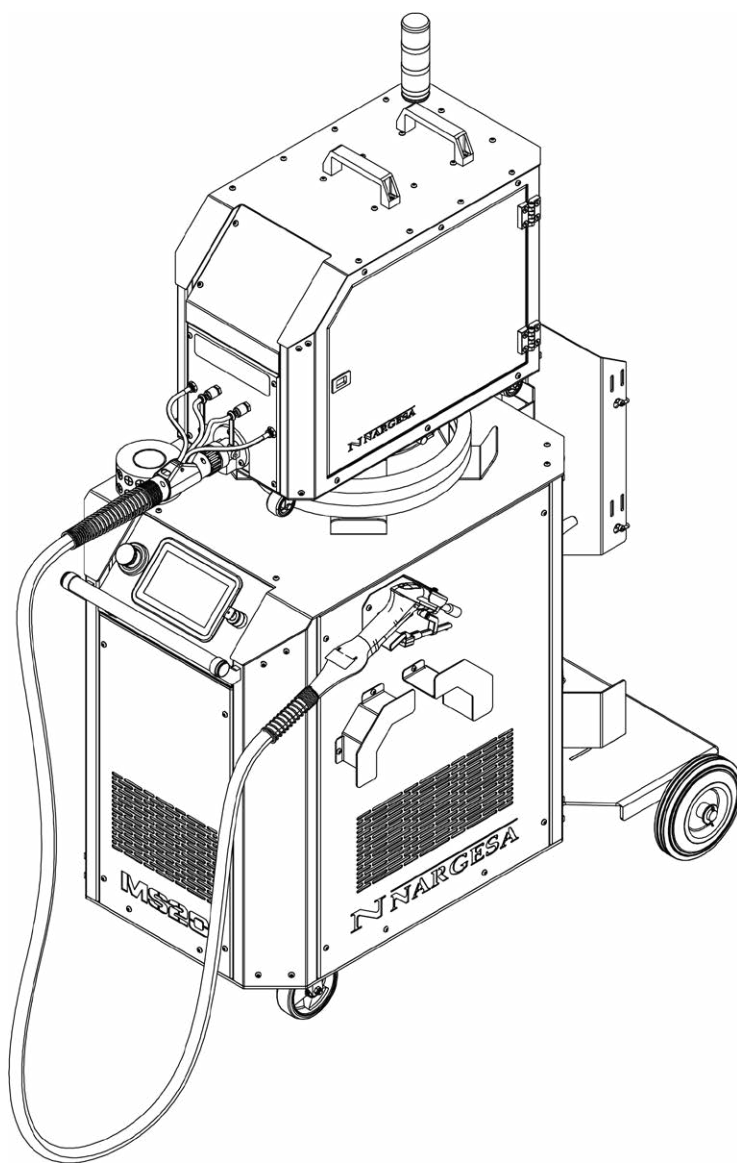

---

PRADA NARGESA, S.L

Ctra. de Garrigàs a Sant Miquel s/n · 17476 Palau de Santa Eulàlia (Girona) SPAIN



Tel. +34 972568085 · nargesa@nargesa.com · www.nargesa.com

## INDEX

A1. General breakdown .....	3
A2. Lower assembly.....	7
A3. Feeder assembly.....	16
A4. Feeder support assembly .....	25
A5. Torch assembly .....	29
A6. Drawer assembly .....	34
A7. Feeder outlet assembly .....	40
A8. Gas accessories assembly .....	42
A9. Electrical cabinets .....	44
A10. Electrical diagrams .....	56

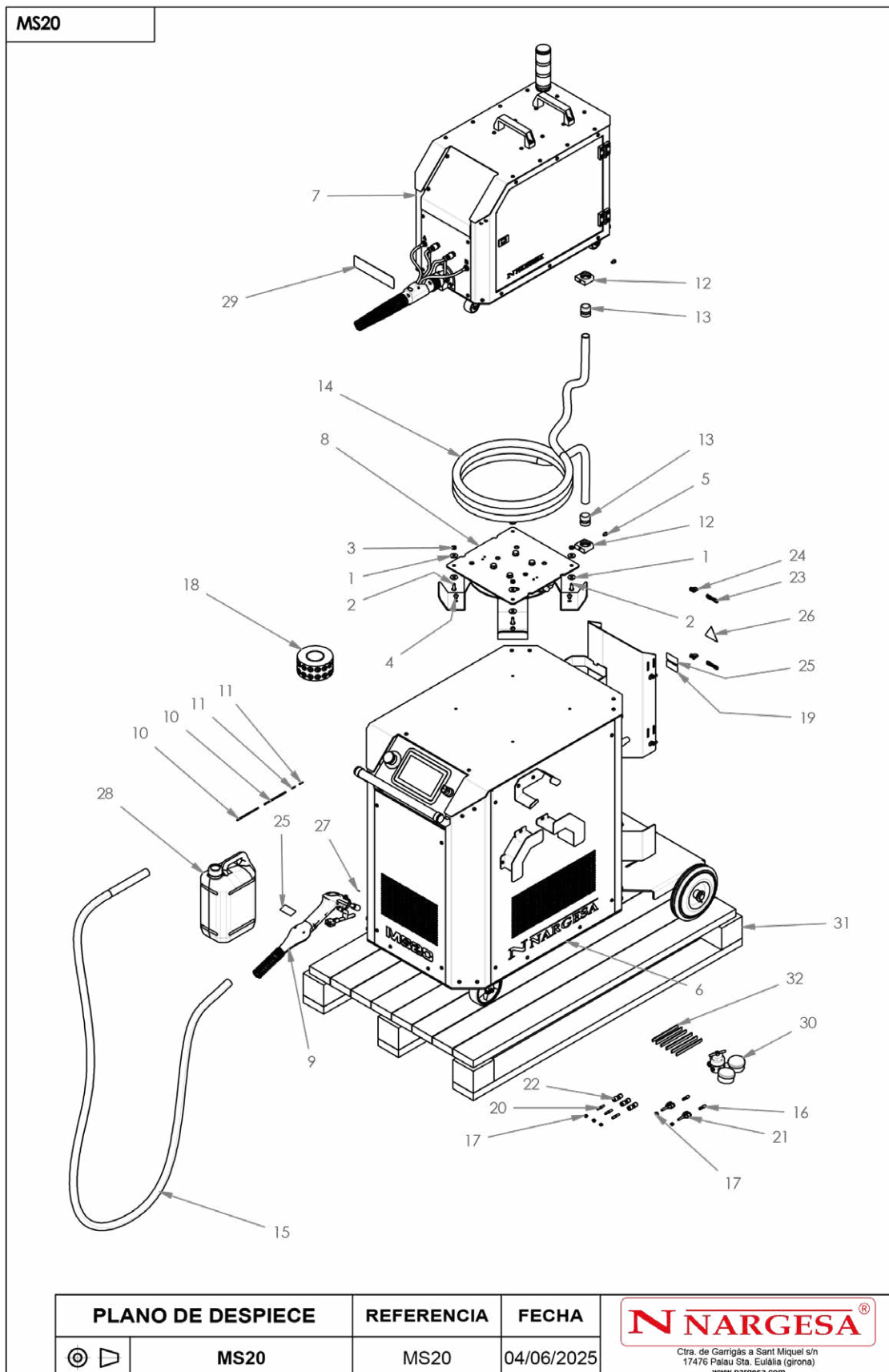
A1. General breakdown



PLANO DE DESPIECE		REFERENCIA	FECHA	 <small>Ctra. de Carrigàs a Sant Miquel s/n 17476 Palau Sta. Eulàlia (Girona) www.nargesa.com</small>
 	MS20	MS20	04/06/2025	

Este plano es propiedad de Prada Nargesa SL. No podrá ser reproducido, comunicado a terceros o utilizado para otro fin que no sea el acordado sin su permiso escrito.

Elemento	Miniatura	Nº de pieza	Descripción	CTDAD
1		020-D9021-M8	Arandela Ancha DIN9021 Para M8	8
2		020-I7380-M8X20	TORNILLO ALLEN ABOMBADO ISO7380 M8X20	4
3		020-D934-M8	Tuerca Hexagonal DIN 934 M8	4
4		020-I7380-M8X10	Tornillo Allen Abombado ISO7380 M8X10	4
5		020-D912-M6X8	TORNILLO ALLEN DIN 912 M6X8	2
6		130-19-01-00001	Conjunto Inferior Maquina de Soldar	1
7		130-19-01-00002	Conjunto Feeder	1
8		130-19-01-00003	Conjunto Soporte Feeder	1
9		130-19-01-00004	Conjunto Antorcha Soldadura MS20	1
10		080-MSL-00302	Sirga De Acero Rojo 1.0-1.2 , 5m	2
11		120-19-01-00115	Funda Termoretractil D4.5 132mm	2



12		031-ABR-00001	Abrazadera Manguera UHE P29	2
13		031-ABR-00002	Conexion Manguera Abrazadera SAT GF M32/P29	2
14		120-19-01-00054	Manguera Maquina Feeder 5mts	1
15		120-19-01-00055	Manguera Feeder Cabezal 5mts	1
16		041-GAS-00027	Racor Pneumatico D4 - Espiga D6	2
17		041-GAS-00029	Abrazadera 2 Orejas 7-9	5
18		080-MSL-00335	Cinta De Centraje	1
19		122-ADH-00030	Adhesivo Laser FDA	1
20		041-GAS-00038	Racor Interno Clavija Reducida D8-D6	3
21		041-GAS-00042	Union Rapida Y D6 aTubo D6	2
22		041-GAS-00026	Racor Pneumatico Reducido D8 - D6	3

23		120-19-01-00118	Cadena Hierro Recta Zinc A MT 3mm	2
24		060-ALM-00087	Grillete Recto Galva M5	4
25		122-CAL-1901-003	Adhesivo Laser CATEGORIA 4	2
26		122-ADH-00029	Adhesivo Triangulo Tension De 50X60	1
27		122-CAL-19-01-004	Adhesivo Triangulo Laser 9x10	1
28		120-19-01-00123	Garrafa Agua Destilada 5L	2
29		122-CAL-1901-006	Calca Advertencias MS20	1
30		080-MSL-00052	Regulador 24l/min MS20	1
31		122-EMB-1901-002	Palet Madera + Rampa MS20	1
32		120-19-01-00122	Velcro Manguera	6

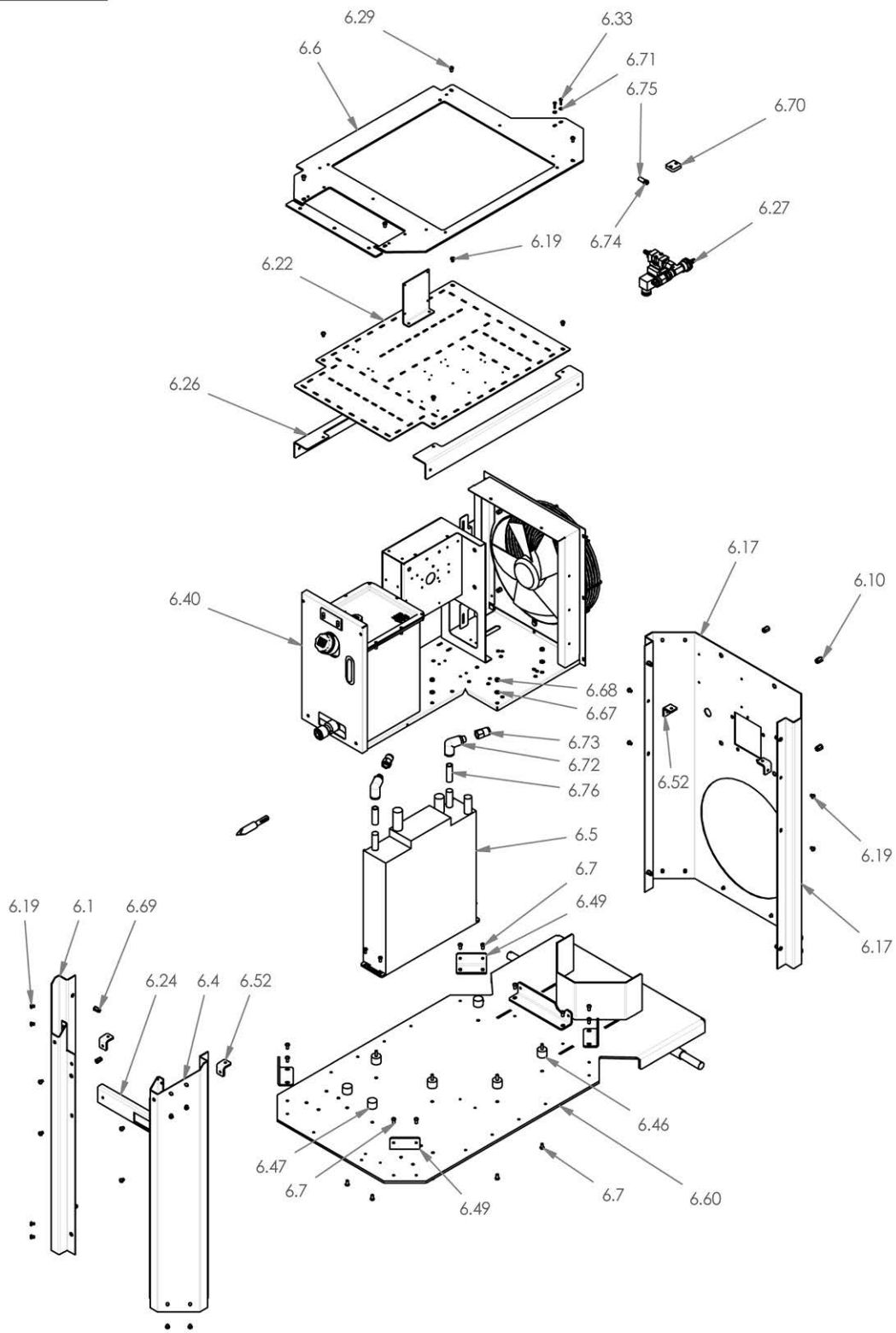

130-19-01-00001



PLANO DE DESPIECE	REFERENCIA	FECHA	 <p>Ctra. de Garrigàs a Sant Miquel s/n 17476 Palau Sta. Eulàlia (Igrona) www.nargesa.com</p>
 <b>Conjunto Inferior Maquina de Soldar</b>	130-19-01-00001	29/08/2024	

Este plano es propiedad de Prada Nargesa SL. No podrá ser reproducido, comunicado a terceros o utilizado para otro fin que no sea el acordado sin su permiso escrito.









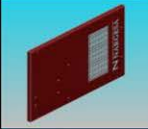

Elemento	Miniatura	Nº de pieza	Descripción	CTDAD
6.1		120-19-01-00002	Esquina Der MS	1
6.2		120-19-01-00010	Lateral 1 Pantalla	1
6.3		120-19-01-00011	Suport Pantalla	1
6.4		120-19-01-00003	Esquina Izq MS	1
6.5		080-MSL-00020	Resonador 2000W	1
6.6		120-19-01-00009	Tapa Intermedia	1
6.7		020-I7380-M6X12	Tornillo Allen Abombado ISO 7380 M6X12	35
6.8		120-19-01-00019	Lateral 2 Pantalla	1
6.9		020-I7380-M6X40	TORNILLO ALLEN CABEZA REDONDA ISO 7380 M6X8	12
6.10		020-D9317-M8	TUERCA REMACHABLE DIN 9317 M8	4
6.11		020-I7380-M8X16	Tornillo Allen ISO 7380 M8X16	4
6.12		020-I7380-M8X12	Tornillo Allen Abombado ISO7380 M8X12	8

6.13		020-D125B-M8	Arandela Biselada DIN 125B M8	8
6.14		120-19-01-00029	Soport Pistola	1
6.15		050-PE-00008	Prensaestopa M25	1
6.16		130-19-01-00008	Chapa Salida Cable V2 N	1
6.17		120-19-01-00004	Trasera MS	1
6.18		130-19-01-00006	Conjunto Asa Parte Inferior Maquina	1
6.19		020-I7380-M6X8	Tornillo Allen Abombado ISO7380 M6X8	65
6.20		130-19-01-00007	Conjunto Cajon	1
6.21		020-D912-M8X16	Tornillo Allen DIN 912 M8x16	2
6.22		050-KIE-1901-001	Cuadro Electrico	1
6.23		120-19-01-00035	Soporte Placa Electrica	1
6.24		120-19-01-00036	Soporte Corto Placa Electrica	1

6.25		120-19-01-00037	Tapa Cuadro Electrico MS20	1
6.26		120-19-01-00038	Soporte Placa Electrica 2	1
6.27		130-19-01-00027	Conjunto Accesorios Gas	1
6.28		020-I7380-M5X12	Tornillo Allen ISO 7380 M5X12	4
6.29		020-I7380-M6X10	Tornillo Allen Abombado ISO 7380 M6X10	8
6.30		020-D125B-M20	Arandela Biselada DIN125B Para M20	4
6.31		120-19-01-00039	Tapa Marco Espuma	1
6.32		020-I7380-M4X4	TORNILLO ISO 7380 M4X4	2
6.33		020-I7380-M4X16	Tornillo Allen Abombado ISO7380 M4X16	2
6.34		050-USB-00002	Conector Pasante USB 2.0	1
6.35		050-ETH-00002	Conector Pasante RJ45 Cat.5	1
6.36		080-MSL-00008	Conector Seguridad Hembra 10-25	1

6.37		031-RG-00002	Rueda H=155mm 480Kg	2
6.38		080-MSL-00016	Rueda D200	2
6.39		080-MSL-00007	Conector Seguridad Macho 10-25	1
6.40		080-MSL-00019	Chiller 2000	1
6.41		120-19-01-00043	Filtro Espuma Frontal 30ppi	1
6.42		122-PLC-0000-001	Placa Caracteristicas General	1
6.43		020-D7337-3X8	Remache De Clavo DIN7337 De Al D3X8	4
6.44		120-19-01-00045	Metacrilato Frontal	1
6.45		050-CNC-00008	S820 PWM	1
6.46		031-SIB-00016	Silentblock D25X20 Macho Hembra M6	4
6.47		031-SIB-00017	Silentblock D25X20 Hembra M6	3
6.48		030-D94-00001	Pasador de Aletas DIN 94 D3.2X30	2

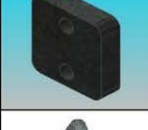
6.49		120-19-01-00012	Uniones Columnas	4
6.50		120-19-01-00013	Uniones Laterales	2
6.51		120-19-01-00014	Uniones Frontales	2
6.52		120-19-01-00016	Suport Chapa Intern.	4
6.53		120-19-01-00018	Uniones Columnas Superiores	2
6.54		120-19-01-00028	Soporte Carril Cajon	2
6.55		120-19-01-00042	Filtro Espuma Lateral 30ppi	2
6.56		120-19-01-00044	Metacrilato Lateral	2
6.57		050-PED-00029	Anillo Luminoso Paro Emergencia	1
6.58		050-PED-00028	Paro Emergencia CAT 4 (2NC+1NO)	1
6.59		130-19-01-00020	Conjunto Soporte Botella	1
6.60		130-19-01-00021	Conjunto Base MS20	1

6.61		130-19-01-00022	Conjunto Tapa MS20	1
6.62		130-19-01-00023	Conjunto Soporte Manguera	2
6.63		130-19-01-00024	Puerta Lateral	1
6.64		130-19-01-00025	Puerta Frontal	1
6.65		130-19-01-00026	Puerta Cajon Lateral	1
6.66		050-SLL-00001	Selector Llave 2 Posiciones. Rb2Bg2	1
6.67		020-D125B-M6	Arandela Biselada DIN 125B M6	4
6.68		020-D934-M6	Tuerca Hexagonal DIN 934 M6	4
6.69		020-D9317-M6-CR	Tuerca Remachable DIN 9317 M6	18
6.70		120-19-01-00112	Chapa Grueso Valvula Gas	1
6.71		020-D125B-M4	Arandela Biselada DIN125B Para M4	2
6.72		041-GAS-00035	Codo Conexion Rapida D16 - Rosca Macho 3/8	2

6.73		041-GAS-00036	Conexion Rapida D12 - Rosca Hembra 3/8	2
6.74		041-GAS-00040	Abrazadera 2 Orejas 9-11	1
6.75		120-19-01-00113	Tubo Gas MS20 10mt	1
6.76		120-19-01-00121	Tubo Conexion Agua Ressonador	2
6.77		120-19-01-00124	Tubo Gas MS20 12x6 20bar 1.5mt	1
6.78		041-GAS-00043	Abrazadera 2 Orejas 11-13	2

**A3. Feeder assembly**

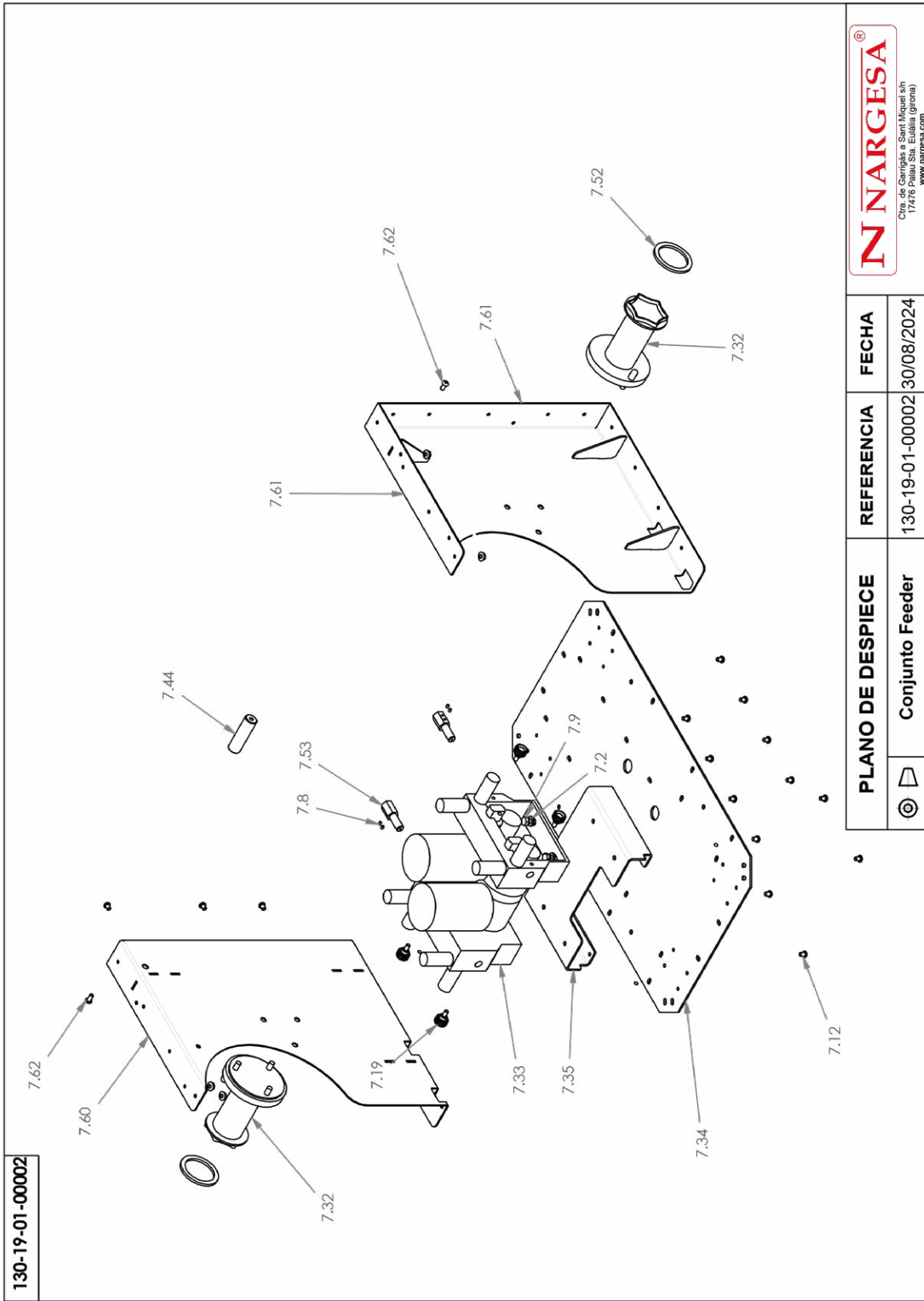

130-19-01-00002



Ctra. de Garrigás a Sant Miquel s/n  
17470 Pals, Sta. Eulària (Girona)  
[www.nargesa.com](http://www.nargesa.com)







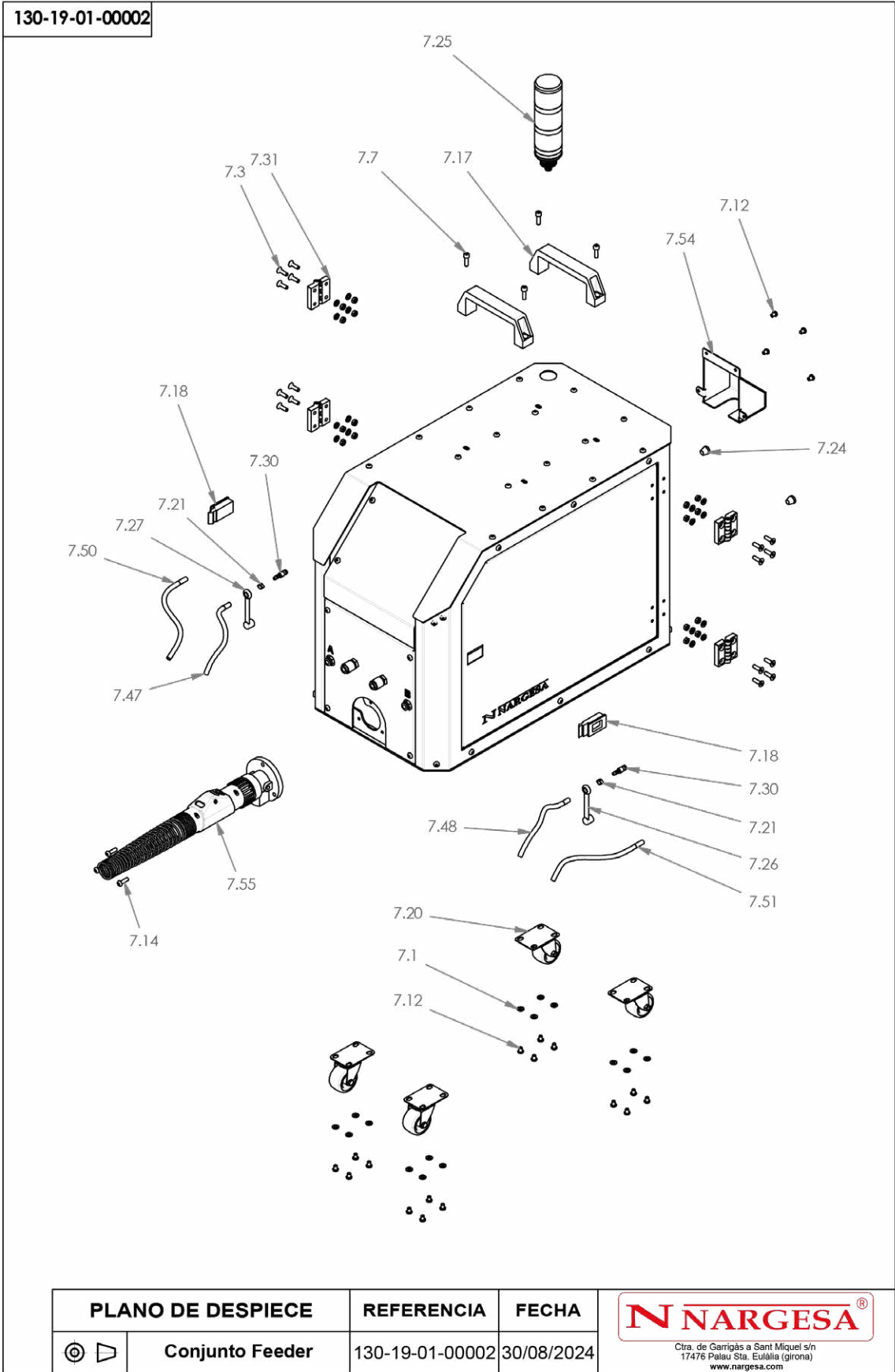

PLANO DE DESPIECE	REFERENCIA	FECHA
 Conjunto Feeder	130-19-01-00002	30/08/2024

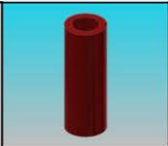
Este plano es propiedad de Prada Nargesa SL. No podrá ser reproducido, comunicado a terceros o utilizado para otro fin que no sea el acordado sin su permiso escrito.

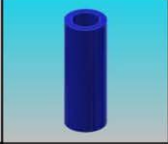









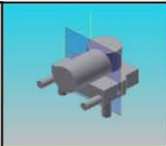

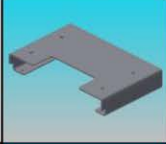
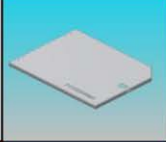
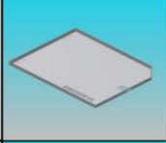



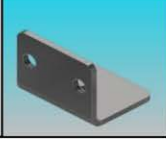

Elemento	Miniatura	Nº de pieza	Descripción	CTDAD
7.1		020-D125B-M6	Arandela Biselada DIN 125B M6	32
7.2		020-D125B-M8	Arandela Biselada DIN 125B M8	4
7.3		020-D7991-M6X20	Tornillo Allen Avellanado DIN7991 M6X20	16
7.4		031-GOM-00001	Gota Adhesiva Transparente	4
7.5		020-D7991-M3x8	Tornillo Allen DIN 7991 M3X8	4
7.6		020-D934-M6	Tuerca Hexagonal DIN 934 M6	16
7.7		020-D912-M6X20	Tornillo Allen DIN912 M6X20	4
7.8		020-D913-M4X5	ESPARRAGO ALLEN DIN 913 M4X5	4
7.9		020-D933-M8X20	TORNILLO HEXAGONAL DIN 933 M8X20	4
7.10		020-D6923-M6	Tuerca DIN 6923 M6	6

7.11		120-19-01-00119	Manguera Agua Caliente 6.3mt	1
7.12		020-I7380-M6X8	Tornillo Allen Abombado ISO7380 M6X8	96
7.13		120-19-01-00120	Manguera Agua Fria 6.3mt	1
7.14		020-I7380-M6X20	Tornillo Allen Abombado ISO7380 M6X20	3
7.15		020-I7380-M6X25	TORNILLO ALLEN ABOMBADO ISO7380 M6X25	4
7.16		020-I7380-M6X30	Tornillo Allen Abombado ISO7380 M6X30	4
7.17		031-APM-00007	Asa Elesa M453	2
7.18		031-MB-00001	Cierre Rapido Plastico Negro	2
7.19		031-POMM-00011	POMO REDONDO D20 M6X10	4
7.20		031-RG-00001	Rueda H=62mm 150Kg	4
7.21		041-GAS-00029	Abrazadera 2 Orejas 7-9	4

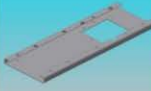
7.22		042-RAC-00002	Racor Recto 1/4 D8	2
7.23		050-LED-00018	Tira Led MS20	1
7.24		050-PSM-00003	Pasamuro KDM/G M12	2
7.25		050-SEM-00001	Semaforo Señalización	1
7.26		080-MSL-00003	Tapa de Cierre Roja	1
7.27		080-MSL-00004	Tapa de Cierre Azul	1
7.28		080-MSL-00009	Conector Rapido Rojo D6mm	1
7.29		080-MSL-00010	Conector Rapido Azul D6mm	1
7.30		080-MSL-00011	Adaptador Rapido D6mm	2
7.31		080-MSL-00014	Bisagra De Plástico 30 Entre Centros	4
7.32		080-MSL-00015	Portabobinas	2

7.33		080-MSL-00024	Motor del Alimentador	2
7.34		120-19-01-00050	Placa Inferior Feeder	1
7.35		120-19-01-00051	Chapa Soporte Alimentador	1
7.36		120-19-01-00056	Puerta Izquierda Feeder	1
7.37		120-19-01-00057	Puerta Derecha Feeder	1
7.38		120-19-01-00058	Escuadra Soporte Manguera	1
7.39		120-19-01-00059	Tapa Superior Frontal Feeder	1
7.40		120-19-01-00060	Frontal Inferior Feeder	1
7.41		120-19-01-00061	Tope Inferior Puerta Feeder	2
7.42		120-19-01-00063	Tope Superior Puerta Feeder	2
7.43		120-19-01-00064	Escuadra Columnas Feeder	4

7.44		120-19-01-00065	Separador Feeder	1
7.45		120-19-01-00066	Soporte Led Feeder	1
7.46		120-19-01-00067	Chapa Trasera Feeder	1
7.47		120-19-01-00068	Manguera Agua Fria 5mt	1
7.48		120-19-01-00069	Manguera Agua Caliente 5mt	1
7.49		120-19-01-00070	Soporte Bornes Feeder	1
7.50		120-19-01-00107	Funda Sirga A 5mt	1
7.51		120-19-01-00108	Funda Sirga B 5mt	1
7.52		120-19-01-00117	Arandela Grueso Bobinas	2
7.53		120-19-01-00116	Salida Alimentador	2
7.54		130-19-01-00009	Chapa Salida Cable V2	1

7.55		130-19-01-00010	Conjunto Salida Feeder	1
7.56		130-19-01-00011	Conjunto Porta Sirga	2
7.57		130-19-01-00012	Conjunto Tapa Superior Feeder	1
7.58		130-19-01-00013	CONJUNTO LATERAL IZQUIERDO FEEDER V5	1
7.59		130-19-01-00014	CONJUNTO LATERAL DERECHO FEEDER V5	1
7.60		130-19-01-00015	conjunto soporte hilo izquierdo feeder V5	1
7.61		130-19-01-00016	conjunto soporte hilo derecho feeder V5	1
7.62		020-I7380-M6X12	Tornillo Allen Abombado ISO 7380 M6X12	4

### A4. Feeder support assembly

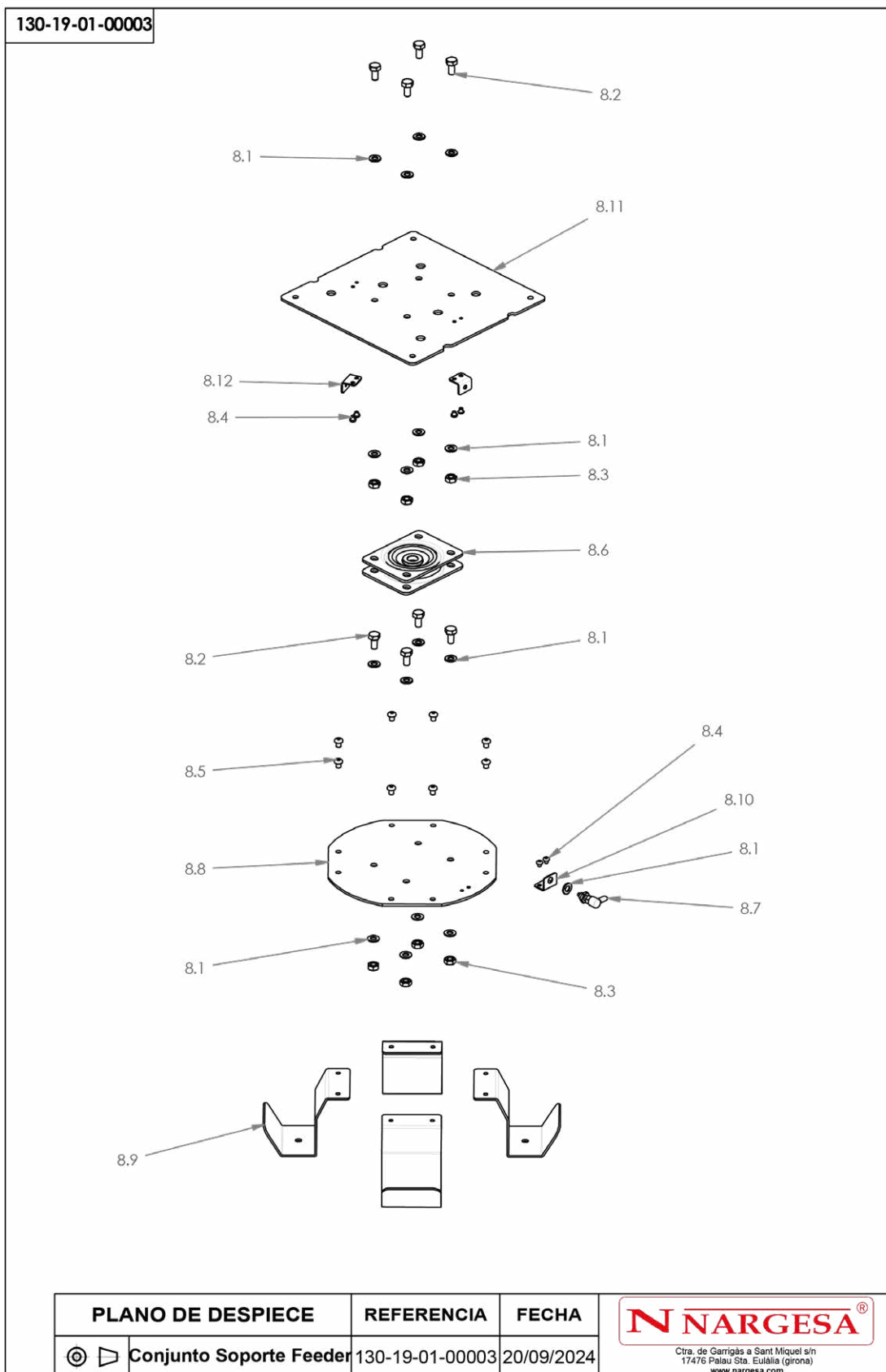

Este plano es propiedad de Prada Nargesa SL. No podrá ser reproducido, comunicado a terceros o utilizado para otro fin que no sea el acordado sin su permiso escrito.

130-19-01-00003

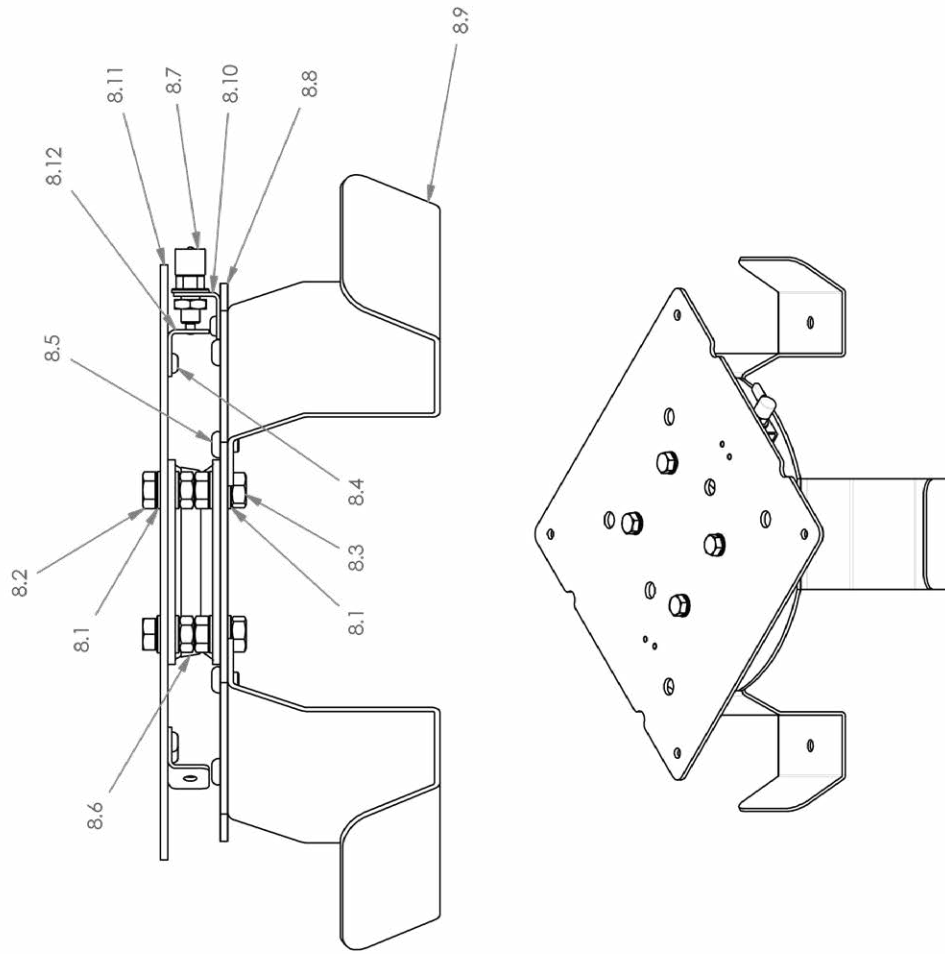



Ctra. de Garrigàs a Sant Miquel s/n  
17476 Palau Sta. Eulàlia (Girona)  
www.nargesa.com

PLANO DE DESPIECE	REFERENCIA	FECHA
	Conjunto Soporte Feeder	20/09/2024

Este plano es propiedad de Prada Nargesa SL. No podrá ser reproducido, comunicado a terceros o utilizado para otro fin que no sea el acordado sin su permiso escrito.

Elemento	Miniatura	Nº de pieza	Descripción	CTDAD
8.1		020-D125B-M10	Arandela Biselada DIN 125B M10	16
8.2		020-D933-M10X20	Tornillo Hexagonal DIN 933 M10X20	8
8.3		020-D934-M10	Tuerca Hexagonal DIN934 M10	8
8.4		020-I7380-M6X6	Tornillo Allen Abombado ISO 7380 M6X6	6
8.5		020-I7380-M8X10	Tornillo Allen Abombado ISO7380 M8X10	8
8.6		030-BG-00001	Base Giratoria	1
8.7		030-BL-00001	Bloqueo M10 D5	1
8.8		120-19-01-00092	Base Giro Feeder	1
8.9		120-19-01-00093	Patas Giratorio Feeder	4
8.10		120-19-01-00094	Soporte Bloqueo Feeder	1

Elemento	Miniatura	Nº de pieza	Descripción	CTDAD
8.11		120-19-01-00095	Base Feeder	1
8.12		120-19-01-00096	Enclavamiento Bloqueo Feeder	2



Elemento	Miniatura	Nº de pieza	Descripción	CTDAD
9.1		020-D7991-M2.5x6	Tornillo Allen DIN 7991 M2.5X8	2
9.2		020-D7991-M3x8	Tornillo Allen DIN 7991 M3X8	3
9.3		080-MSL-00026	Muelle Trasero Metalico Kit	1
9.4		080-MSL-00037	Conjunto Antorcha Soldadura MS20	1
9.5		130-19-01-00028	Conjunto Union Sirgas	2
9.6		120-19-01-00105	Mitad Externa Empuñadura	1
9.7		120-19-01-00106	Mitad Interna Empuñadura	1
9.8		122-CAL-1901-001	Adhesivo Cabezal Laser Nargesa1	1
9.9		122-CAL-1901-002	Adhesivo Cabezal Laser Nargesa 2	1
9.10		020-D912-M3X12	TORNILLO ALLEN DIN 912 M3X12	4



Elemento	Miniatura	Nº de pieza	Descripción	CTDAD
9.4.1		080-MSL-00017	Cabezal de Soldadura Laser	1
9.4.2		080-MSL-00036	Soporte Guia Aportacion	1
9.4.3		080-MSL-00035	Guia Aportacion	1
9.4.4		080-MSL-00039	Guia Enfoque FT80	1
9.4.5		080-MSL-00041	Soporte Lente Proteccion	1
9.4.6		080-MSL-00042	Soporte Lente Enfoque	1
9.4.7		080-MSL-00032	Tapa Placa Pistola	1
9.4.8		080-MSL-00048	Placa Interruptor Cabezal HD30LED200	1
9.4.9		080-MSL-00046	Placa Ahislante HD31-01-023T	1
9.4.10		080-MSL-00043	Adaptador Alimentador HD31-01-002T	1

9.4.11		080-MSL-00045	Tuerca de Sujecion HD30-01-015T	1
9.4.12		080-MSL-00044	Manguito de Sujecion HD31-01-016T	1
9.4.13		080-MSL-00049	Placa Gatillo Cabezal HD31KB200	1
9.4.14		040-JT-00105	Junta Frontal Lentes	2
9.4.15		080-MSL-00325	Junta Lente Proteccion HD30-01-030T	1
9.4.16		080-MSL-00324	Junta Lente Enfoque HD30-01-029T	1
9.4.17		040-JT-00104	JUNTA TORICA D18X1 Nbr 70 Shore	2
9.4.18		020-D912-M6X16	Tornillo Allen DIN912 M6X16	1

**A6. Drawer assembly**

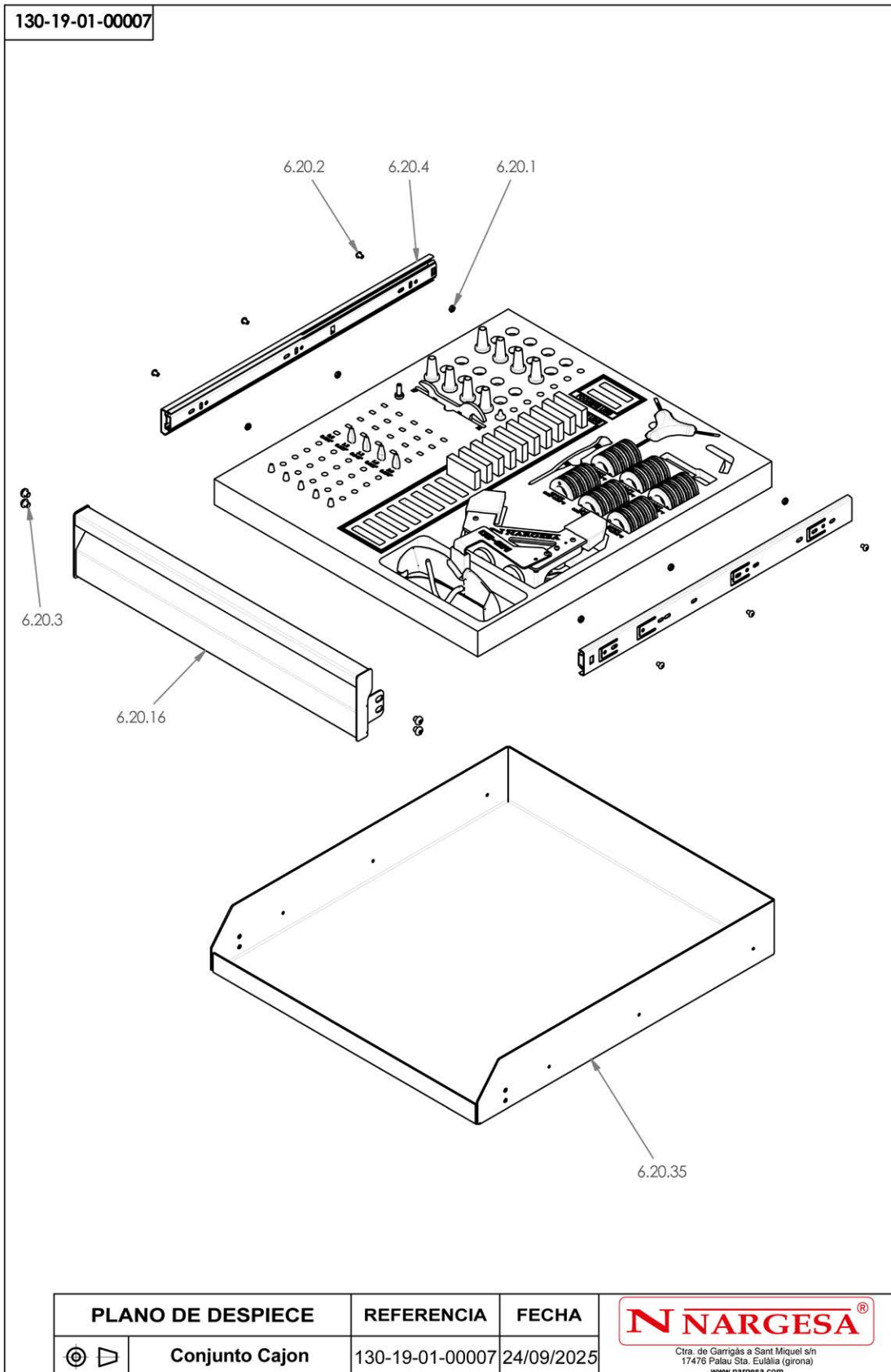



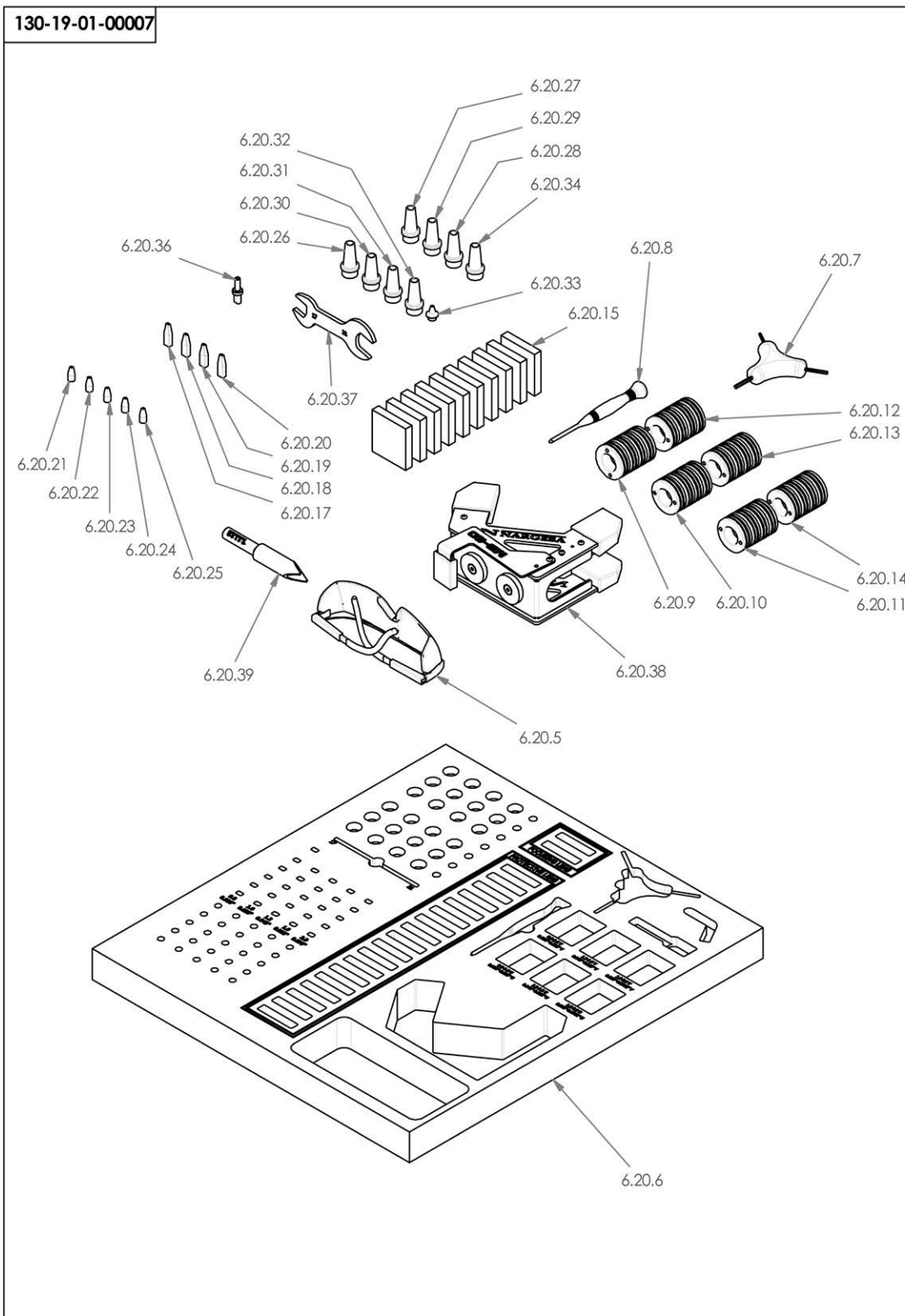









Este plano es propiedad de Prada Nargesa SL. No podrá ser reproducido, comunicado a terceros o utilizado para otro fin que no sea el acordado sin su permiso escrito.





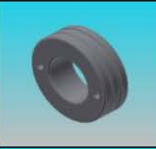

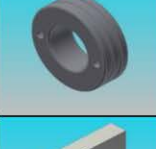
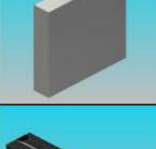
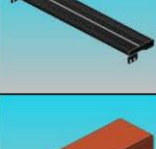
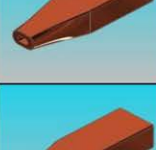
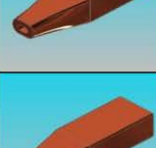
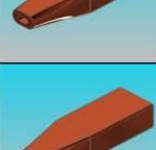
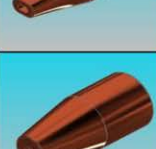
PLANO DE DESPIECE		REFERENCIA	FECHA	 <small>Ctra. de Garrigàs a Sant Miquel s/n 17476 Palau Sta. Eulàlia (Girona) www.nargesa.com</small>
©	▶	Conjunto Cajon	130-19-01-00007	

Este plano es propiedad de Prada Nargesa SL. No podrá ser reproducido, comunicado a terceros o utilizado para otro fin que no sea el acordado sin su permiso escrito.

Elemento	Miniatura	Nº de pieza	Descripción	CTDAD
6.20.1		020-D934-M4	Tuerca Hexagonal DIN934 M4	6
6.20.2		020-I7380-M4X6	Tornillo Allen Abombado ISO7380 M4X6	6
6.20.3		020-I7380-M6X6	Tornillo Allen Abombado ISO 7380 M6X6	4
6.20.4		030-GC-00001	Guia Cajon 450mm	2
6.20.5		080-MSL-00021	Gafas Proteccion Laser LP-ADY-3	1
6.20.6		080-MSL-00027	Espuma Cajon MS20	1
6.20.7		080-MSL-00029	Allen 2-2.5-3	1
6.20.8		080-MSL-00030	Destornillador Philips	1
6.20.9		080-MSL-00326	Rodillo 0,8 - 1,0mm U	4
6.20.10		080-MSL-00327	Rodillo 1,2 - 1,6mm U	4

6.20.11		080-MSL-00328	Rodillo 1,6 - 2,0mm U	4
6.20.12		080-MSL-00329	Rodillo 0,8 - 1,0mm V	4
6.20.13		080-MSL-00330	Rodillo 1,2 - 1,6mm V	4
6.20.14		080-MSL-00331	Rodillo 1,6 - 2,0mm V	4
6.20.15		080-MSL-00332	Lente de Proteccion	10
6.20.16		130-19-01-00019	Conjunto Frontal Cajon	1
6.20.17		080-MSL-00402	Boquilla Aportacion Doble 1.0mm	1
6.20.18		080-MSL-00403	Boquilla Aportacion Doble 1.2mm	1
6.20.19		080-MSL-00404	Boquilla Aportacion Doble 1.6mm	1
6.20.20		080-MSL-00405	Boquilla Aportacion Doble 2.0mm	1
6.20.21		080-MSL-00406	Boquilla Aportacion Simple 0.8mm	1

6.20.22		080-MSL-00407	Boquilla Aportacion Simple 1.0mm	1
6.20.23		080-MSL-00408	Boquilla Aportacion Simple 1.2mm	1
6.20.24		080-MSL-00409	Boquilla Aportacion Simple 1.6mm	1
6.20.25		080-MSL-00410	Boquilla Aportacion Simple 2.0mm	1
6.20.26		080-MSL-00413	Boquilla de Soldadura Laser C	1
6.20.27		080-MSL-00415	Boquilla Soldadura 1,2mm AS-12	1
6.20.28		080-MSL-00416	Boquilla Soldadura 1,6mm BS-16	1
6.20.29		080-MSL-00419	Boquilla Soldadura 1,2mm CS-12	1
6.20.30		080-MSL-00425	Boquilla Doble Soldadura 1,2mm AS-12D	1
6.20.31		080-MSL-00426	Boquilla Doble Soldadura 1,6mm AS-16D	1
6.20.32		080-MSL-00428	Boquilla Corte CT-15	1

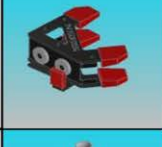
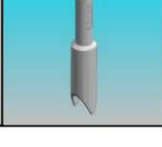
6.20.33		080-MSL-00429	Puntera Boquilla Corte 1,5mm CT-15	1
6.20.34		080-MSL-00431	Boquilla Soldadura 1,6mm ES-16 - FS-16	1
6.20.35		120-19-01-00088	Base Cajon	1
6.20.36		120-19-01-00091	Boquilla Aportacion Doble a Simple	1
6.20.37		120-19-01-00109	Clau 17-21	1
6.20.38		130-19-01-00018	Soporte Cabezal Laser Imantado	1
6.20.39		080-MSL-00430	Boquilla de Limpieza	1

**A7. Feeder outlet assembly**

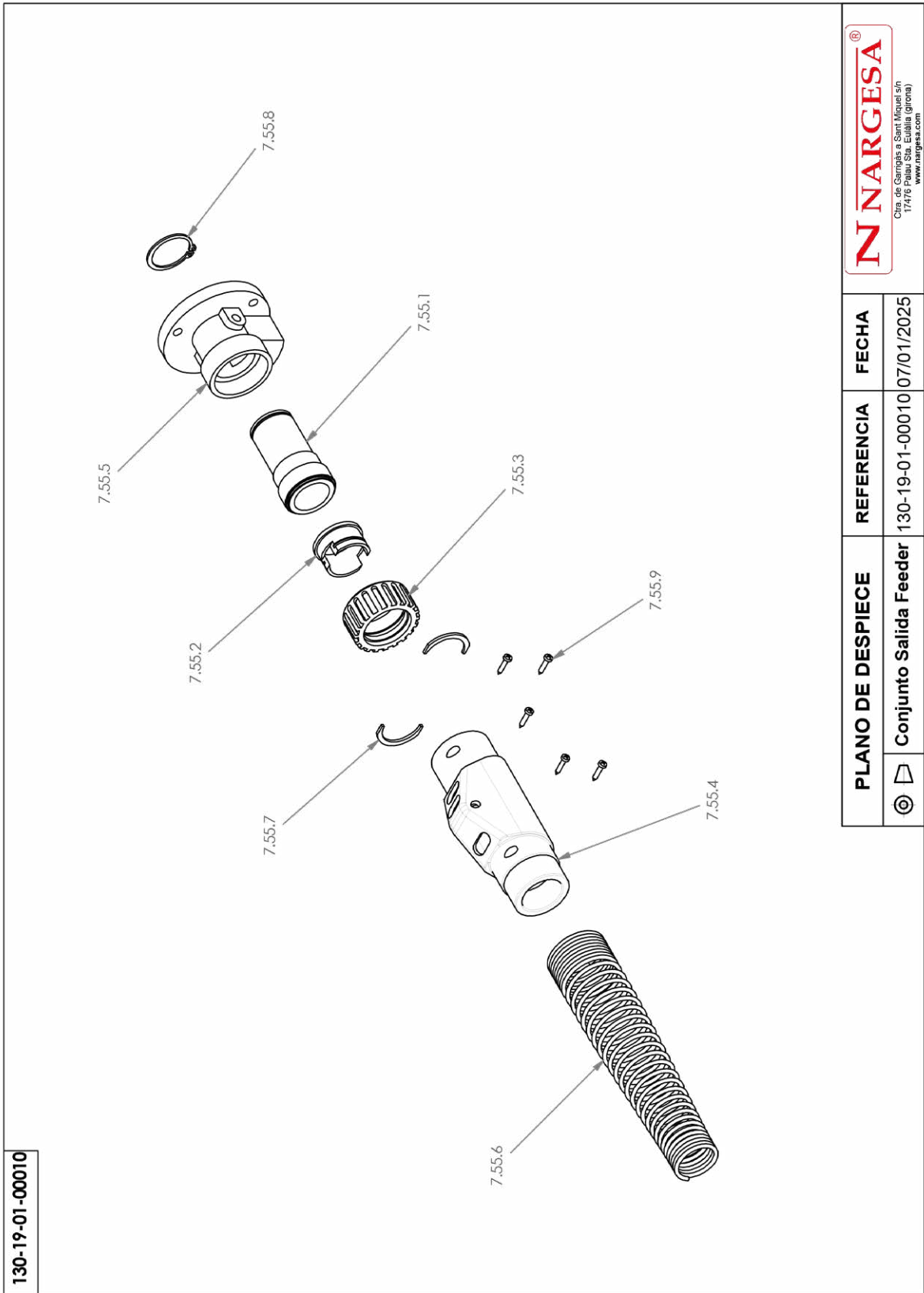

130-19-01-00010

PLANO DE DESPIECE	REFERENCIA	FECHA
	130-19-01-00010	07/01/2025
	Conjunto Salida Feeder	

Elemento	Miniatura	Nº de pieza	Descripción	CTDAD
7.55.1		120-19-01-00071	Rosca Conector Euro Manguera	1
7.55.2		120-19-01-00072	Fijacion Media Luna Manguera	1
7.55.3		080-MSL-00005	Tuerca Conector Manguera	1
7.55.4		080-MSL-00002	Acople Manguera	1
7.55.5		080-MSL-00006	Euroadaptador Manguera	1
7.55.6		080-MSL-00001	Muelle Manguera	1
7.55.7		120-19-01-00073	Media Luna Fijación Manguera	2
7.55.8		030-D471-00021	Circlip Eje Din471 D32X1.5	1
7.55.9		020-D7981-00003	Tornillo DIN 7981 Ø3.2X16 Cabeza Alomada PHILIPS	5

**A8. Gas accessories assembly**

**130-19-01-00027**

Una X indica que se debe poner teflón líquido!

The diagram shows an exploded view of a gas valve assembly. The main valve body is at the bottom left. Various fittings, nuts, and seals are shown in their relative positions. 'X' marks are placed on several components: a nut (6.27.5), a seal (6.27.2), a nut (6.27.3), a nut (6.27.4), a nut (6.27.6), a nut (6.27.7), a nut (6.27.8), and a connector (6.27.1). The parts are labeled with their respective part numbers: 6.27.1, 6.27.2, 6.27.3, 6.27.4, 6.27.5, 6.27.6, 6.27.7, and 6.27.8.

**N NARGESA®**  
Ctra. de Garrigás a Sant Miquel s/n  
 17476 Palafrugell, Eulalia (Girona)  
 www.nargesa.com

PLANO DE DESPIECE	REFERENCIA	FECHA
	<b>Conjunto Accesorios Gas</b> 130-19-01-00027	11/11/2024

Este plano es propiedad de Prada Nargesa S.L. No podrá ser reproducido, comunicado a terceros o utilizado para otro fin que no sea el acordado sin su permiso escrito.

Elemento	Miniatura	Nº de pieza	Descripción	CTDAD
6.27.1		041-GAS-00020	PRESOST. MOD.41 1/4 NC 1-10 BAR	1
6.27.2		041-GAS-00031	EV 2/2 NC Accion Directa Laton DN 5 3/8" 0-10 BAR 24VDC	1
6.27.3		040-RMM-00003	Racor 3/8" Macho Macho	1
6.27.4		040-JMG-00004	Junta Metal Goma 3/8' Gas	2
6.27.5		041-GAS-00032	Espiga M 3/8 D8	2
6.27.6		041-GAS-00033	Pasatabique M-H 3/8-1/4	1
6.27.7		040-TGC-00002	Figura "T" Tuerca Giratoria Central 3/8"	1
6.27.8		041-GAS-00034	Adaptador H-H Reducido 3/8 a 1/4	1

**A9. Electrical cabinets**

-CONTROL1

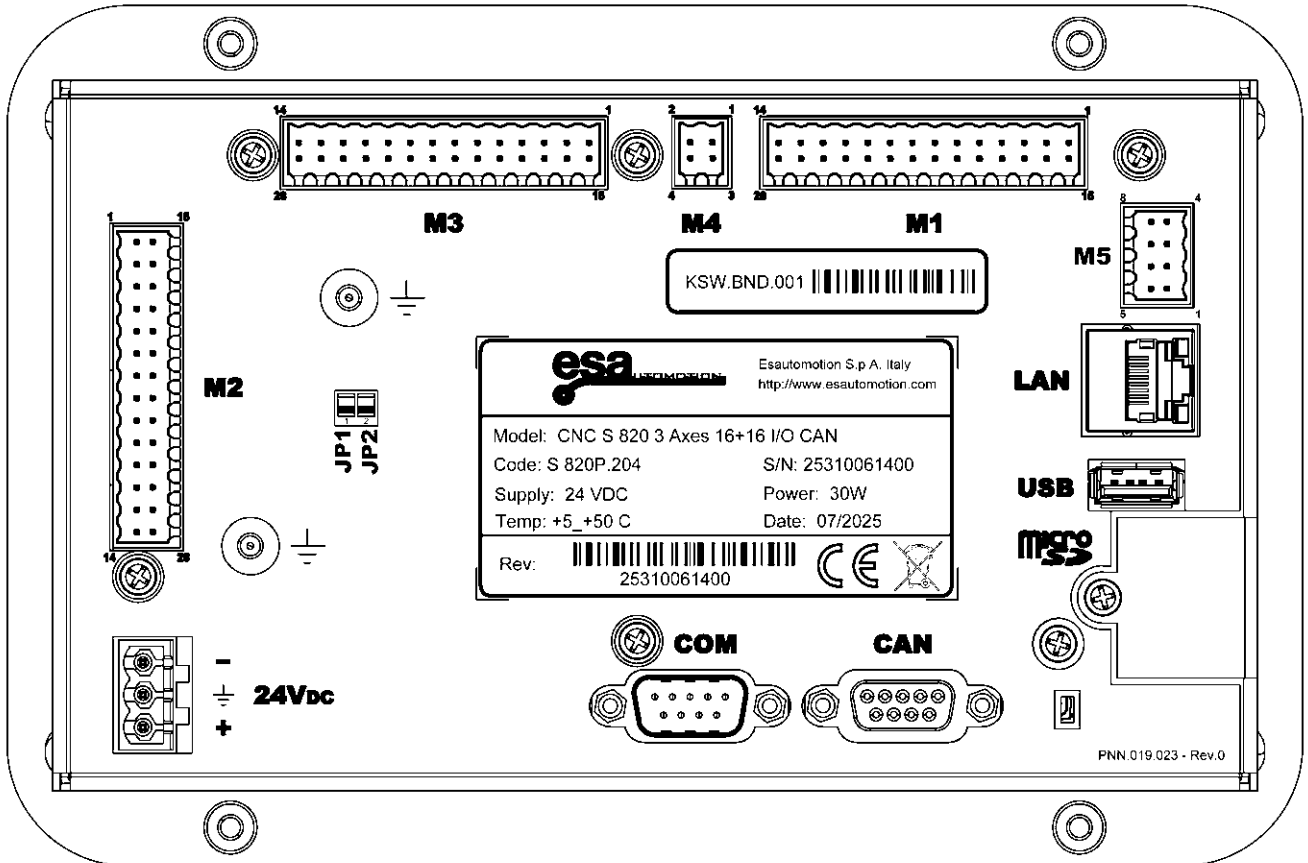



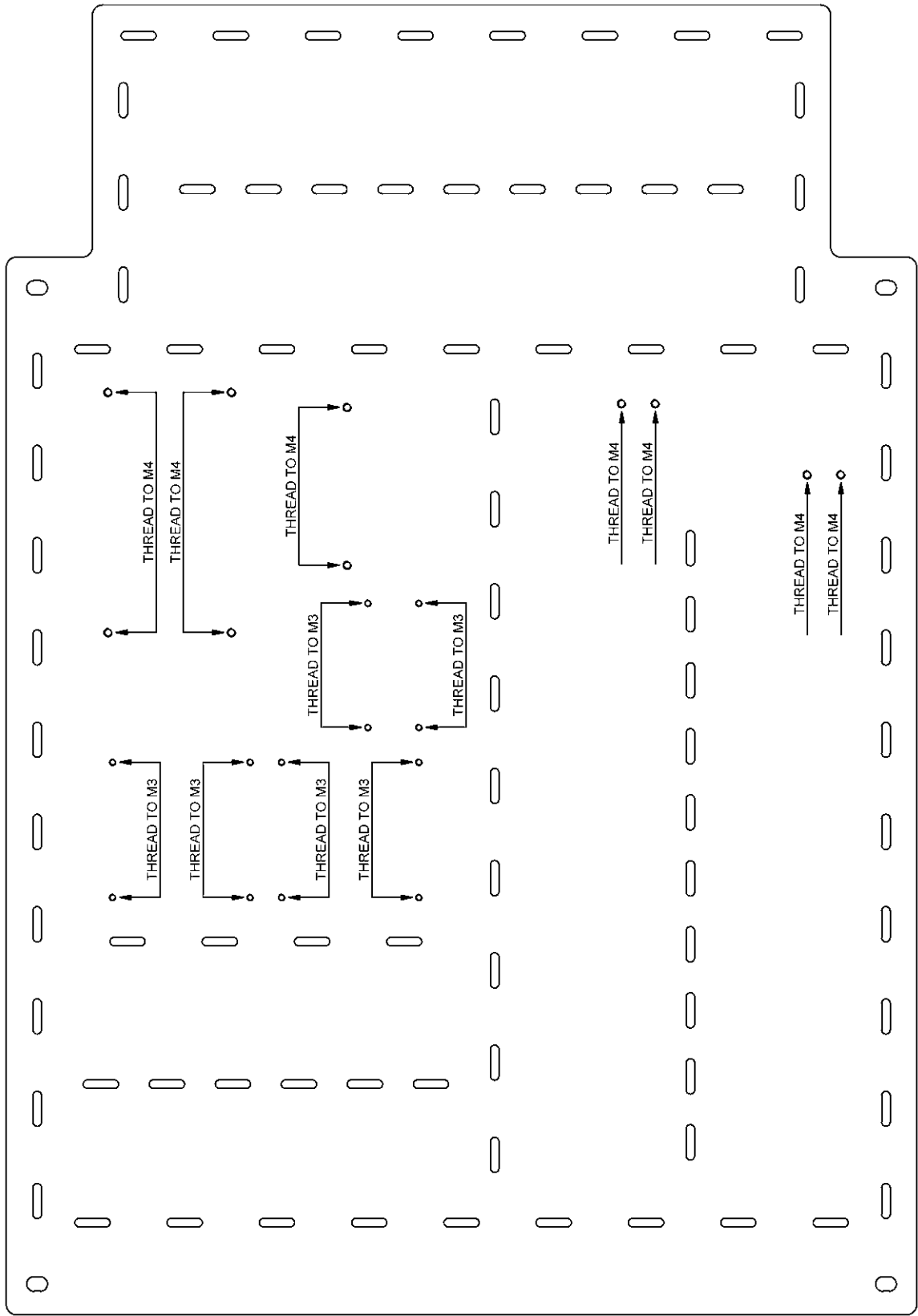

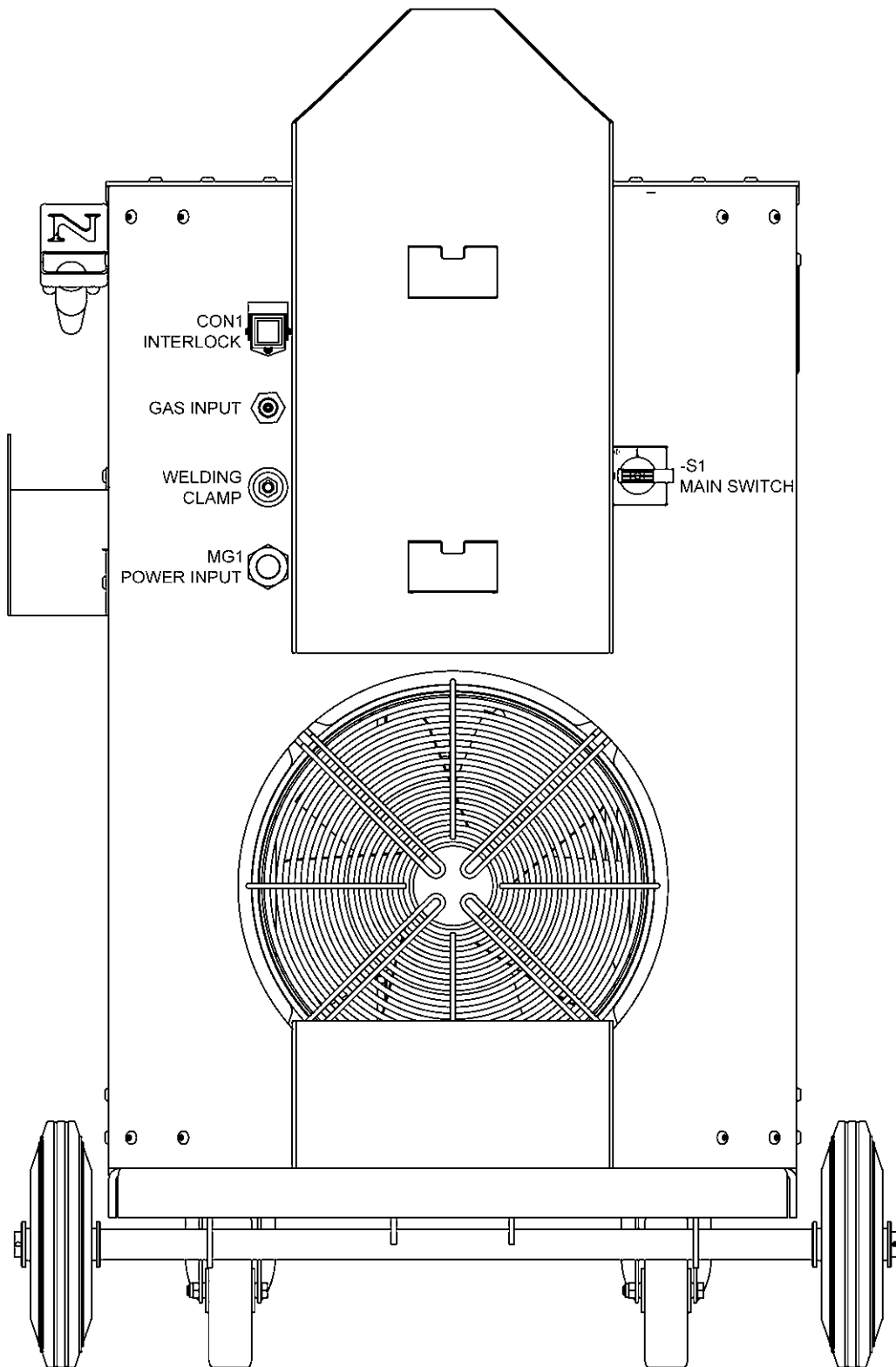

## CONTROL PANEL INNER VIEW

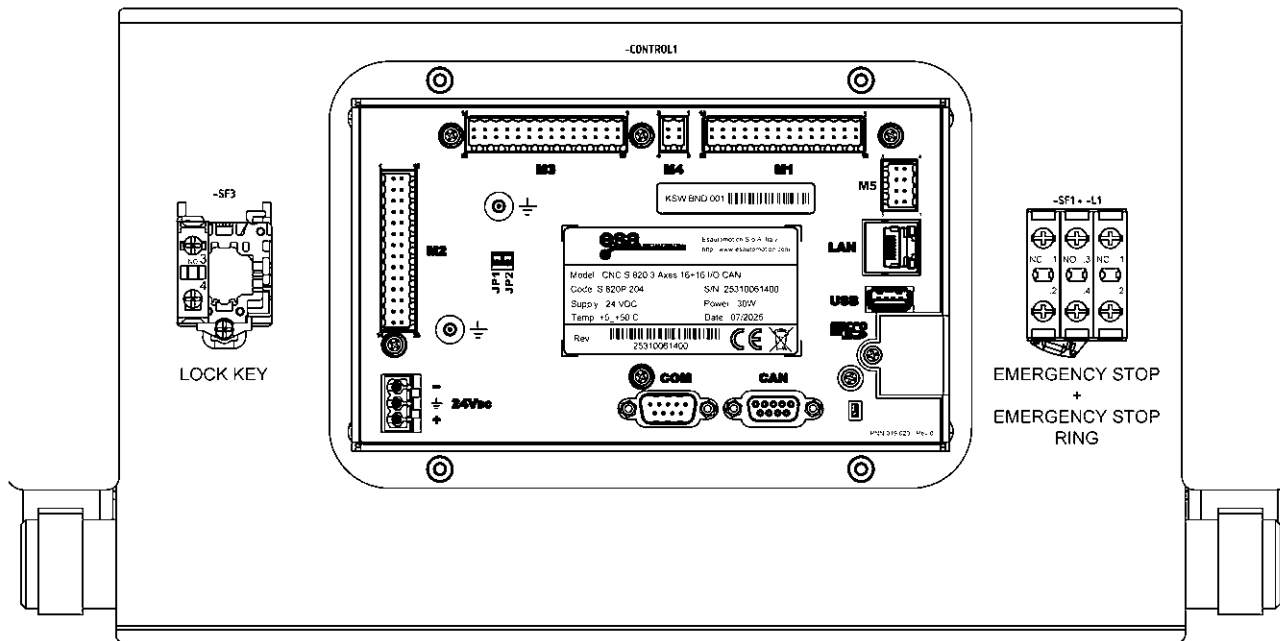

¡Attention!

To attach the ESA S820 control to the chassis use:

x4 zinc plated washer Out  $\varnothing$  = 11.8 mm  
 In  $\varnothing$  = 4.4 mm  
 Thickness = 0.9 mm

x4 zinc plated locknut M4

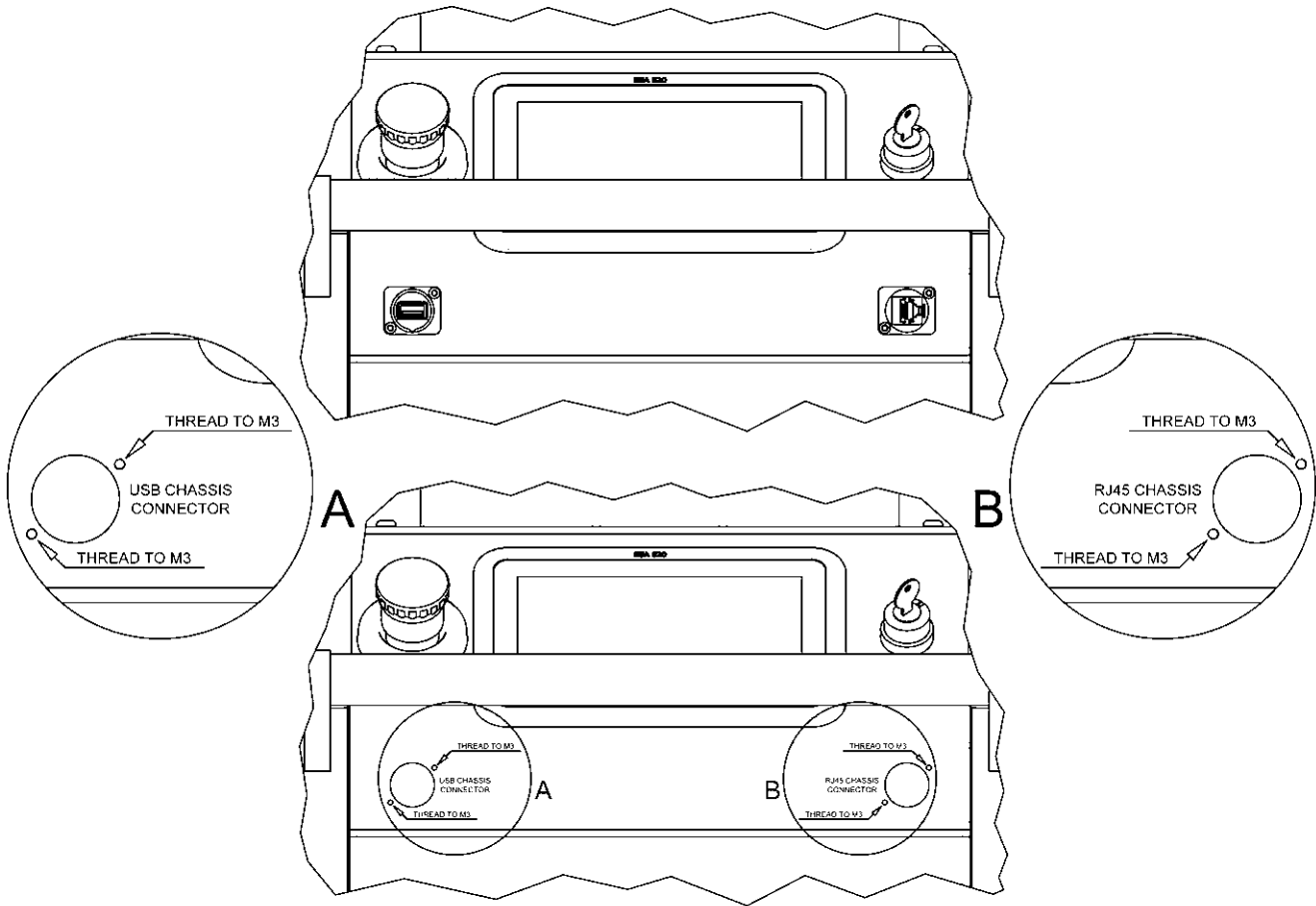

MG6 + MG7 (GUN SIGNALS + GUN MOTOR)

MG15 (SEMAPHORE + WIRE FEEDER)

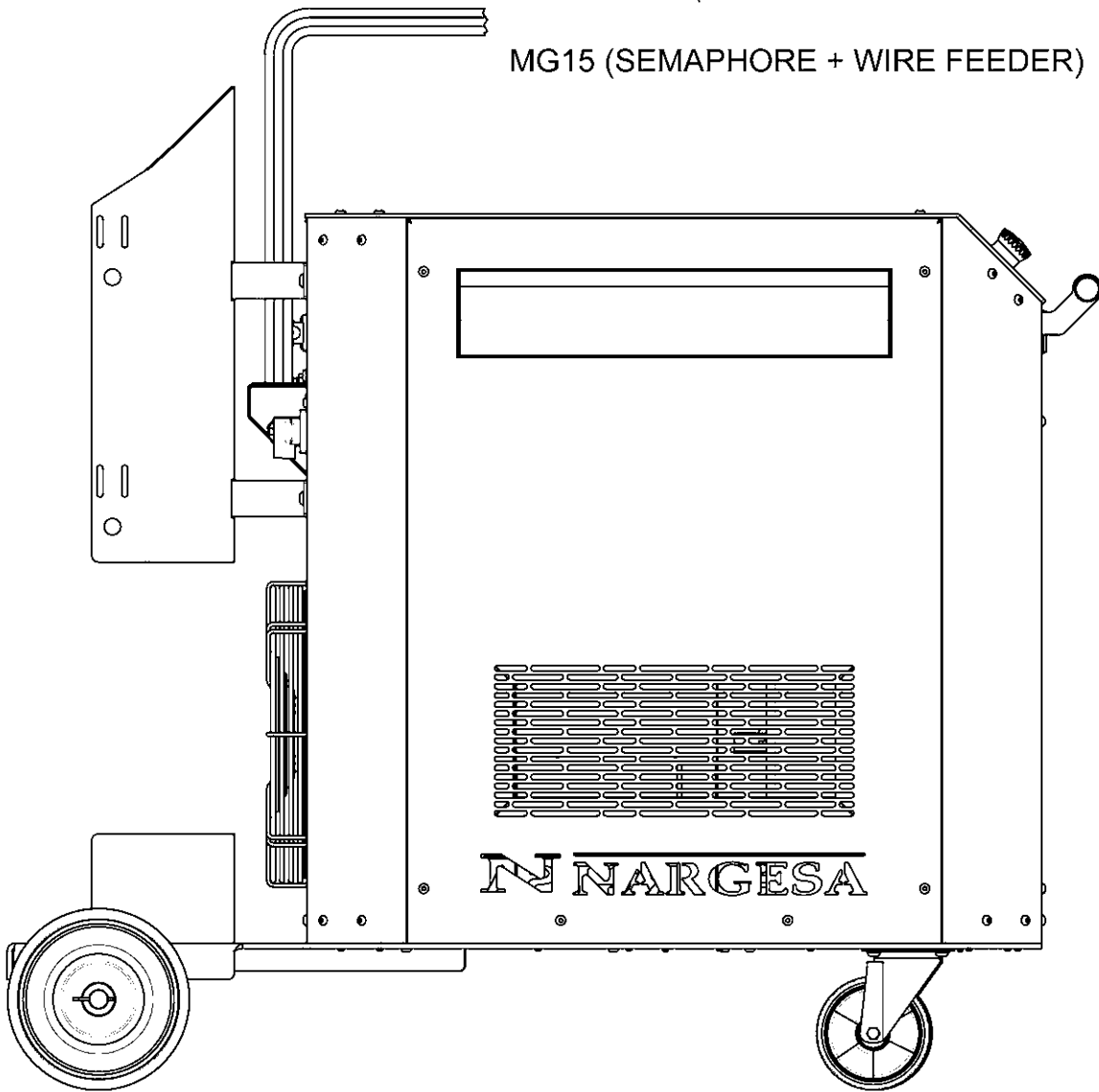

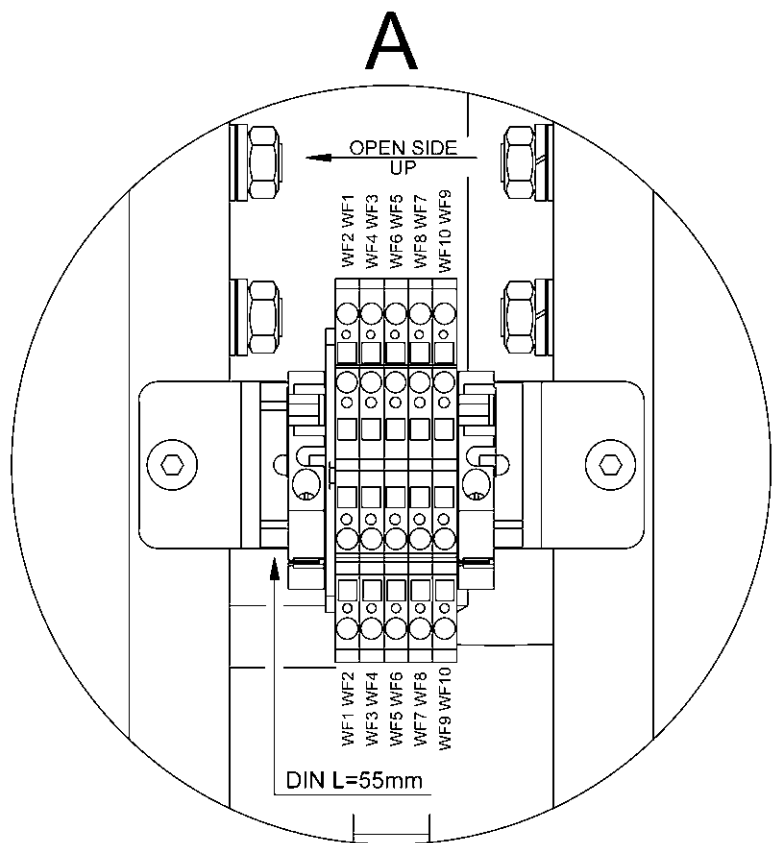
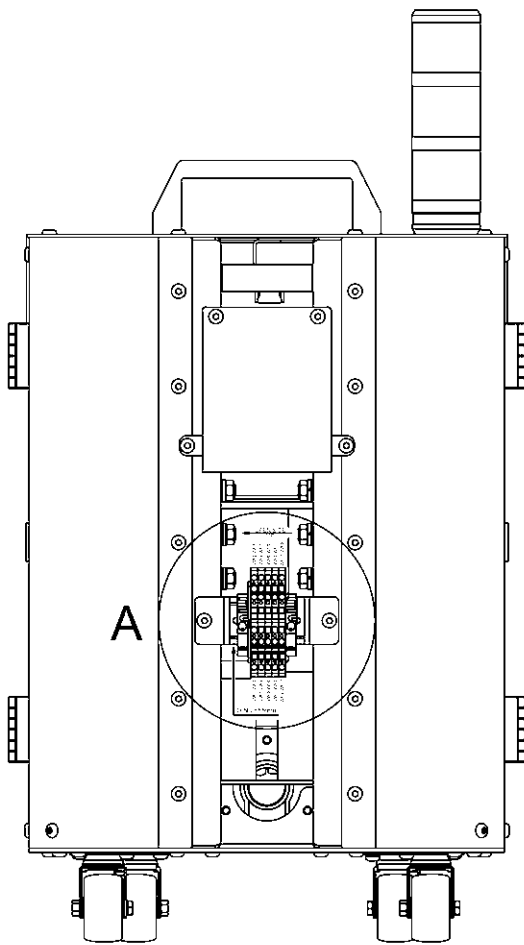

-LWHD1

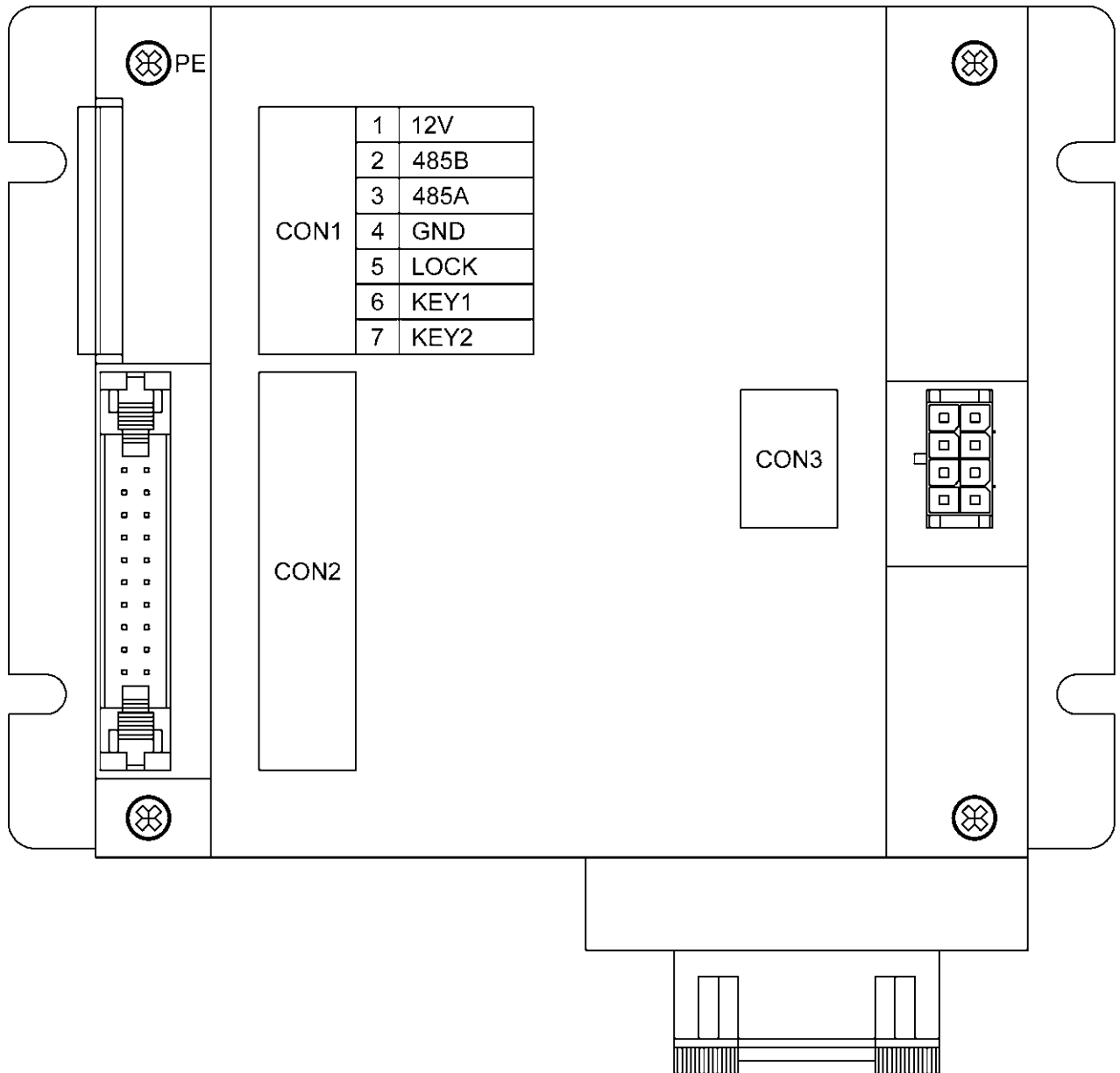

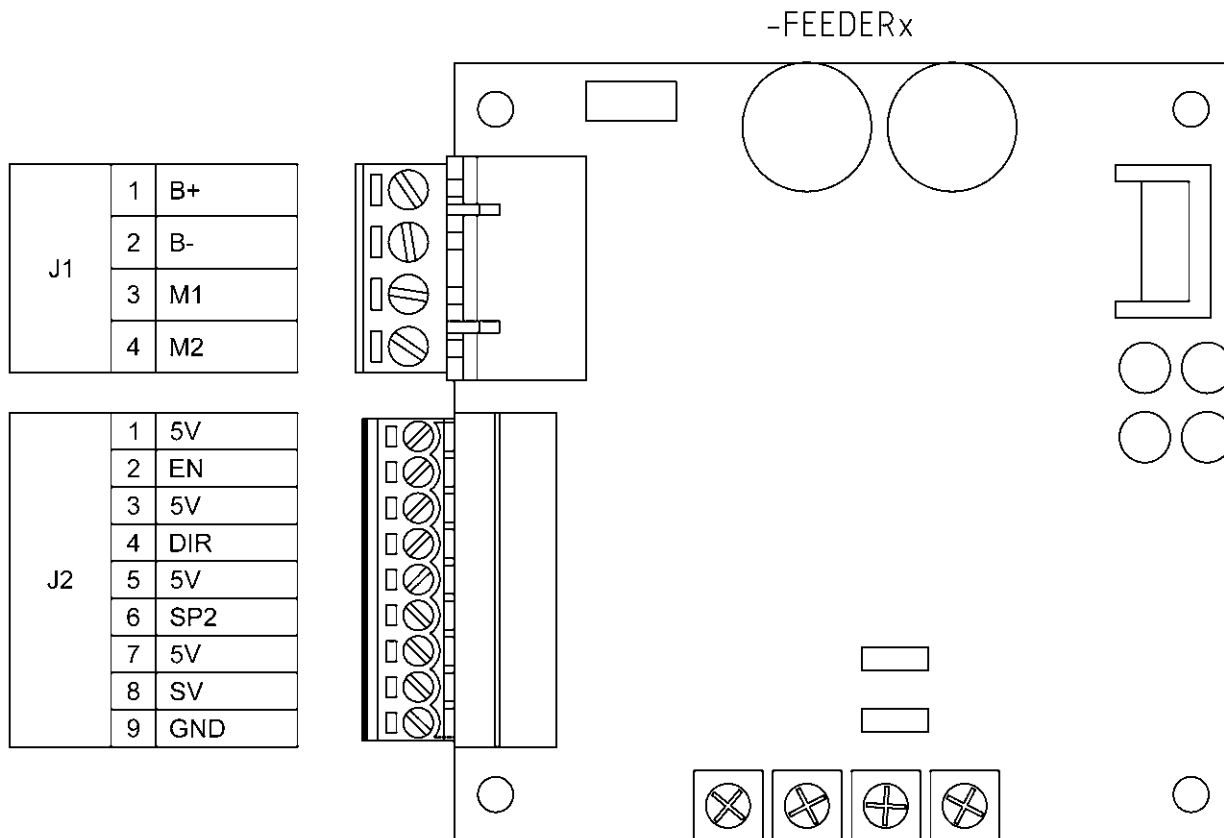

Max. output voltage	Torque	Accel. / Decel. time	Output current
Adjustment			

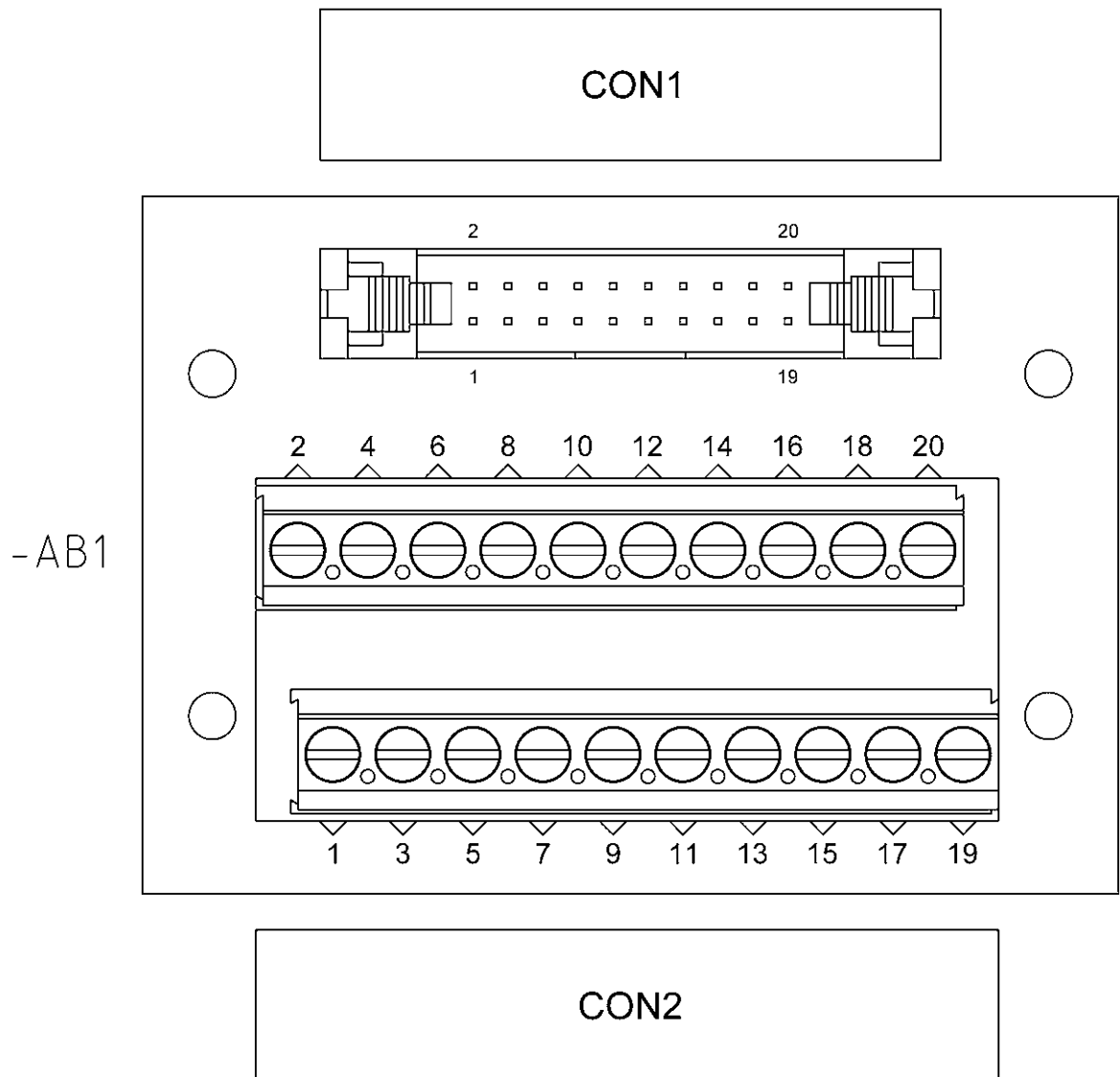

MOUNTING DETAILS FOR THE MOUNTING PLATE

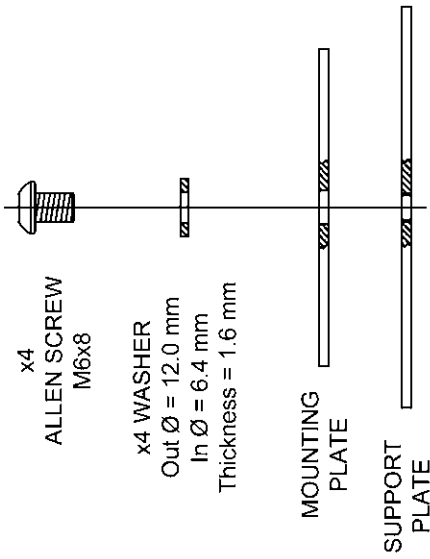

MOUNTING DETAILS FOR THE LASER WELDING HEAD DRIVER BOARD

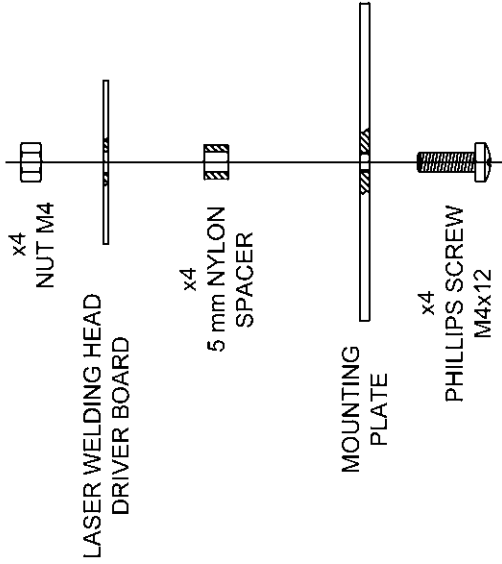

MOUNTING DETAILS FOR THE FEEDER BOARD

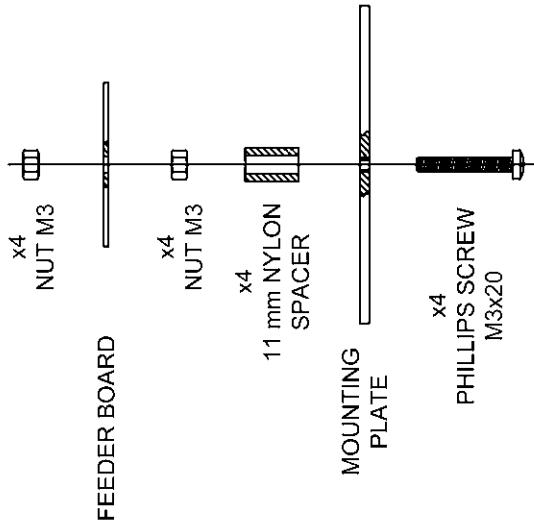

MOUNTING DETAILS FOR THE RS232 TO RS485 CONVERTER

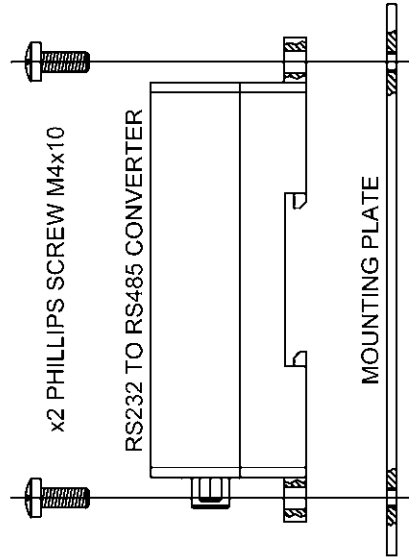

MOUNTING DETAILS FOR THE IDC20 ADAPTER BOARD

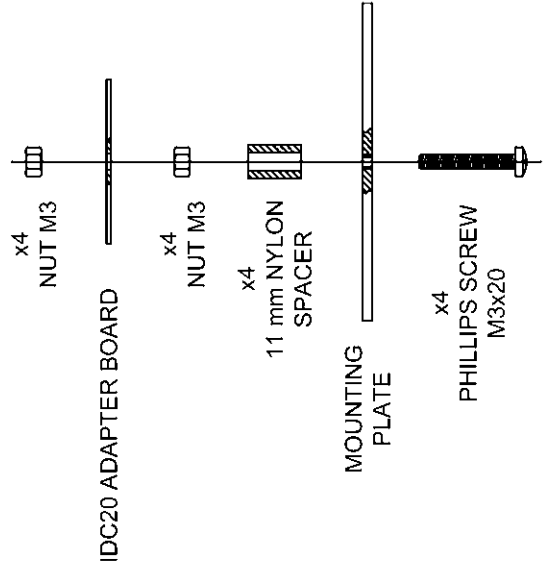

MOUNTING DETAILS FOR THE -FA2 POWER SUPPLY

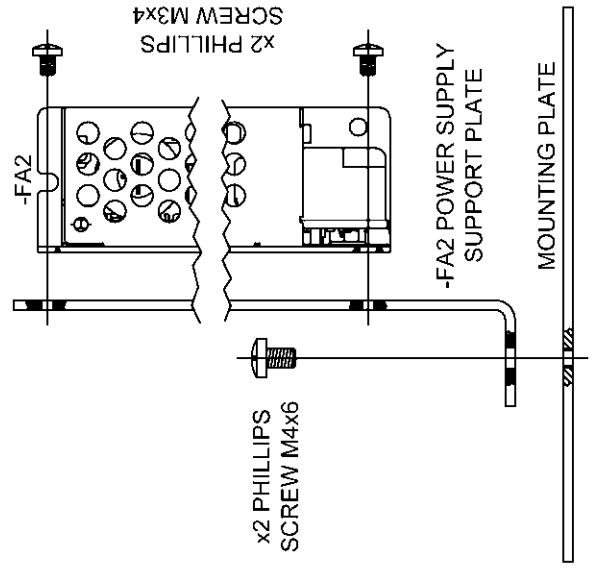

**A10. Electrical diagrams**

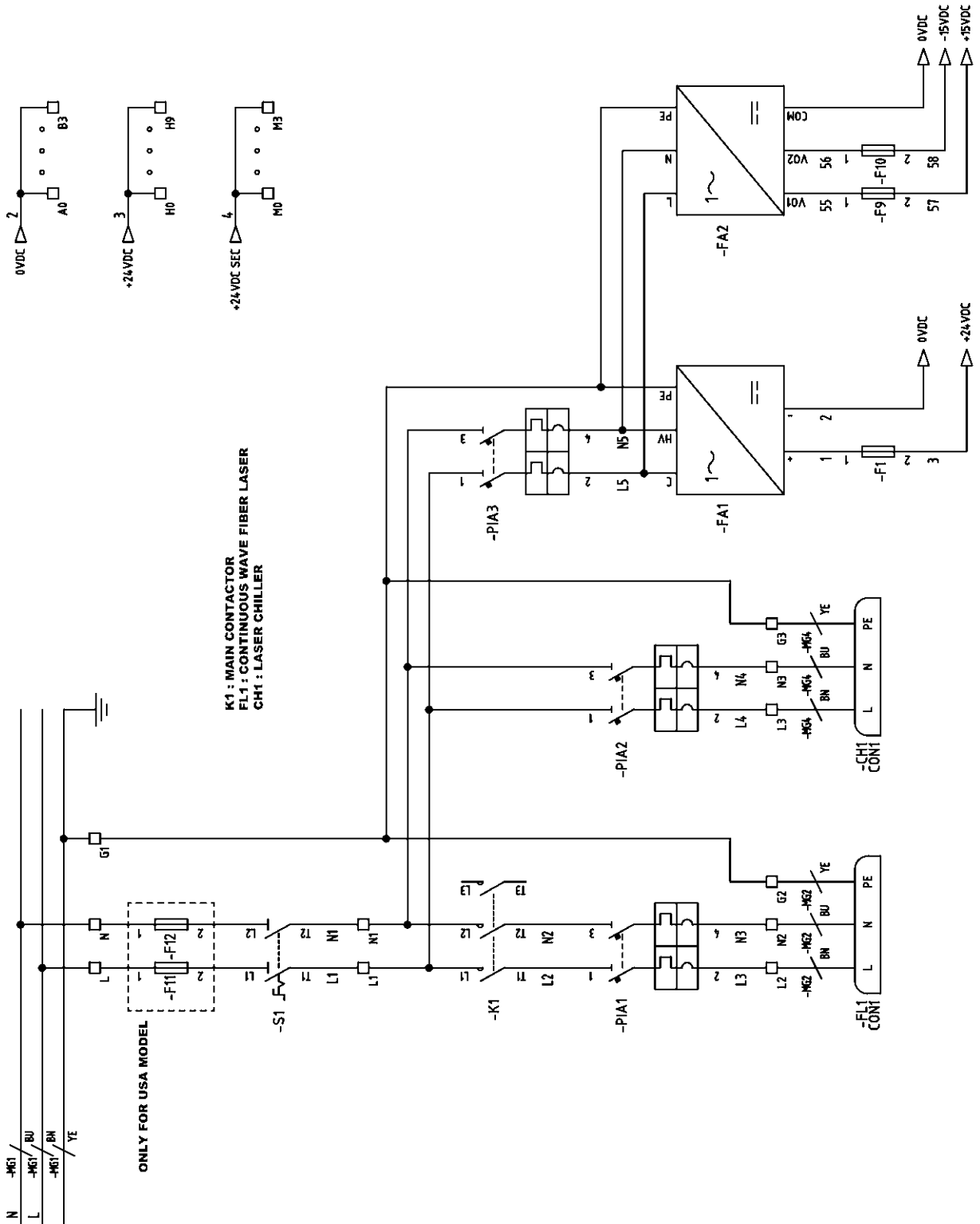

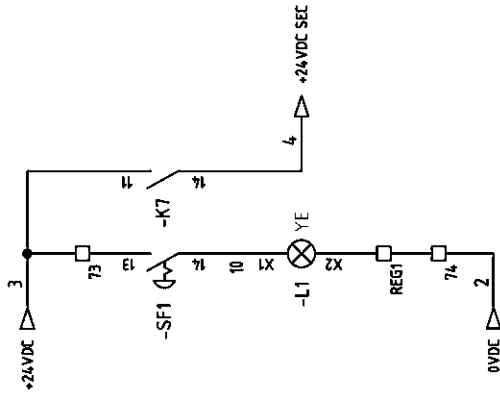

SEG1 : SAFETY MODULE  
 K6 : CONTINUOUS WAVE FIBER LASER ENABLE RELAY  
 K7 : EMERGENCY STOP RELAY  
 K8 : LASER WELDING CLAMP SAFETY RELAY  
 SF1 : EMERGENCY STOP  
 SF3 : CONTINUOUS WAVE FIBER LASER LOCK KEY  
 CON1 : INTERLOCK  
 L1 : EMERGENCY STOP RING

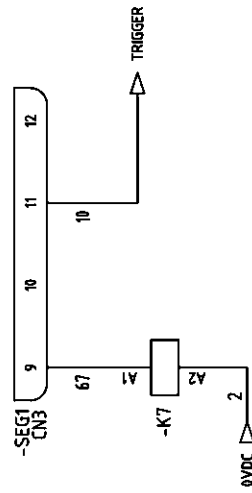
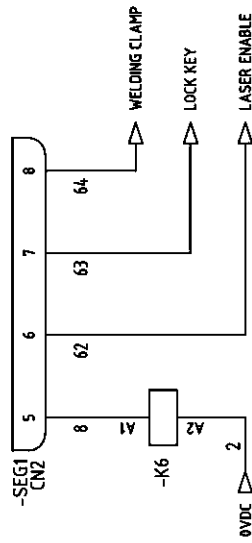
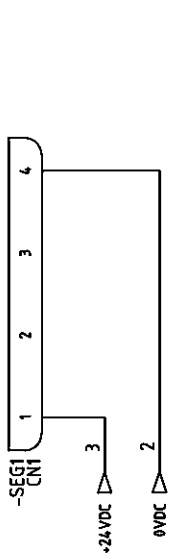
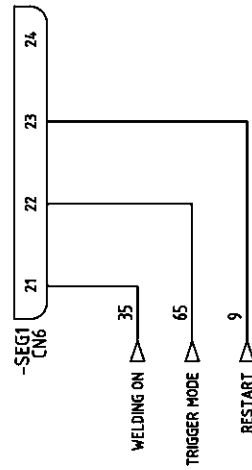
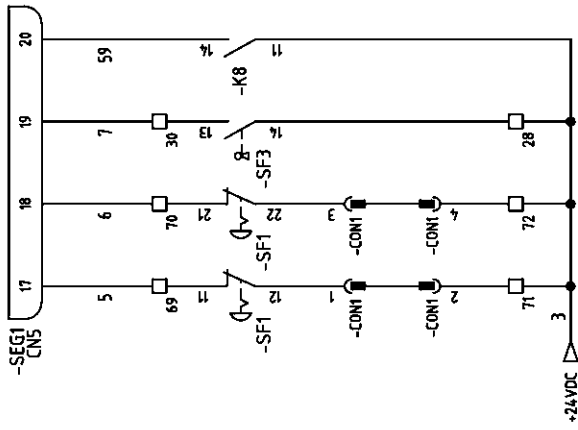

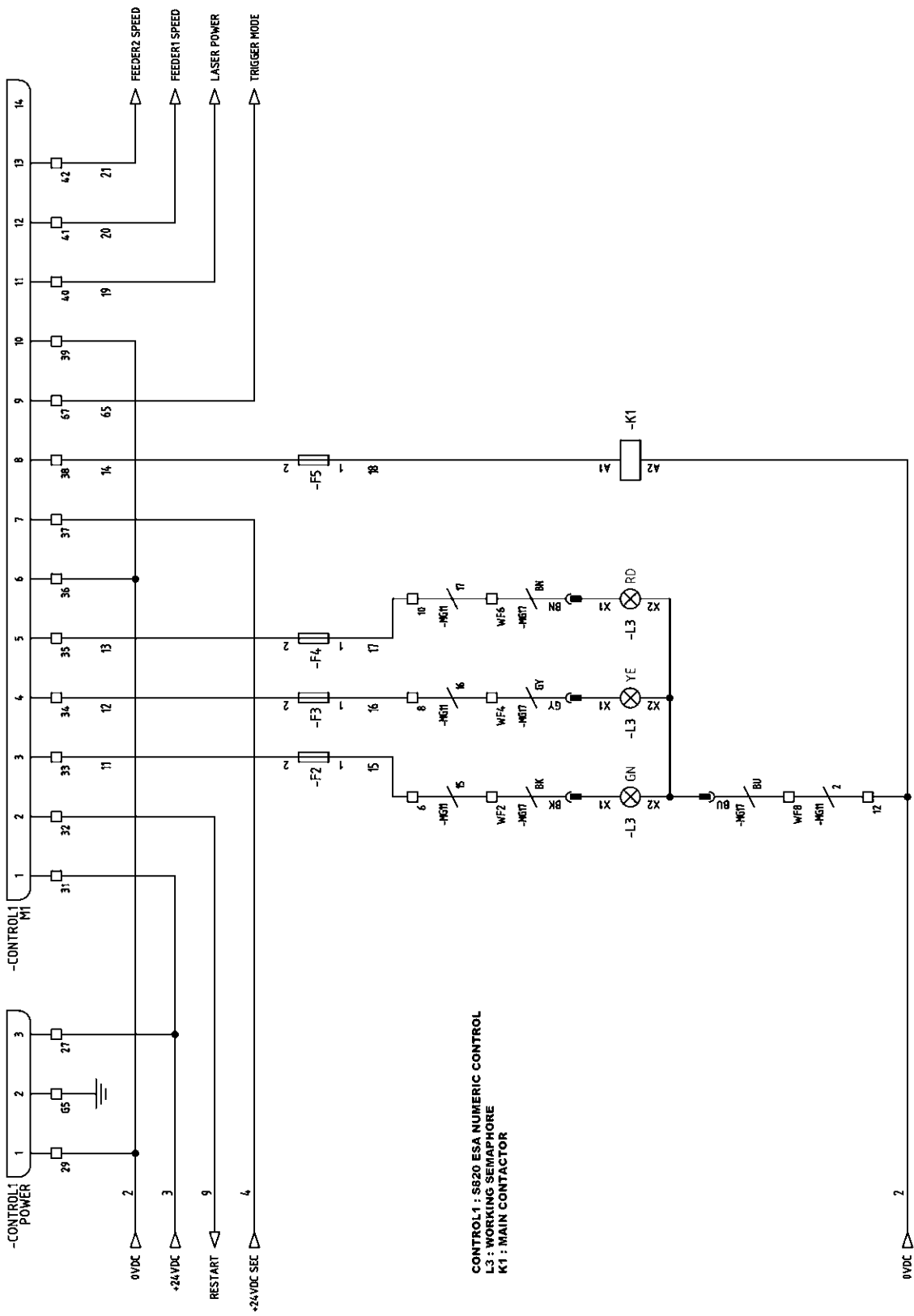

CONTROL 1 : S820 ESA NUMERIC CONTROL  
 L3 : WORKING SEMAPHORE  
 K1 : MAIN CONTACTOR

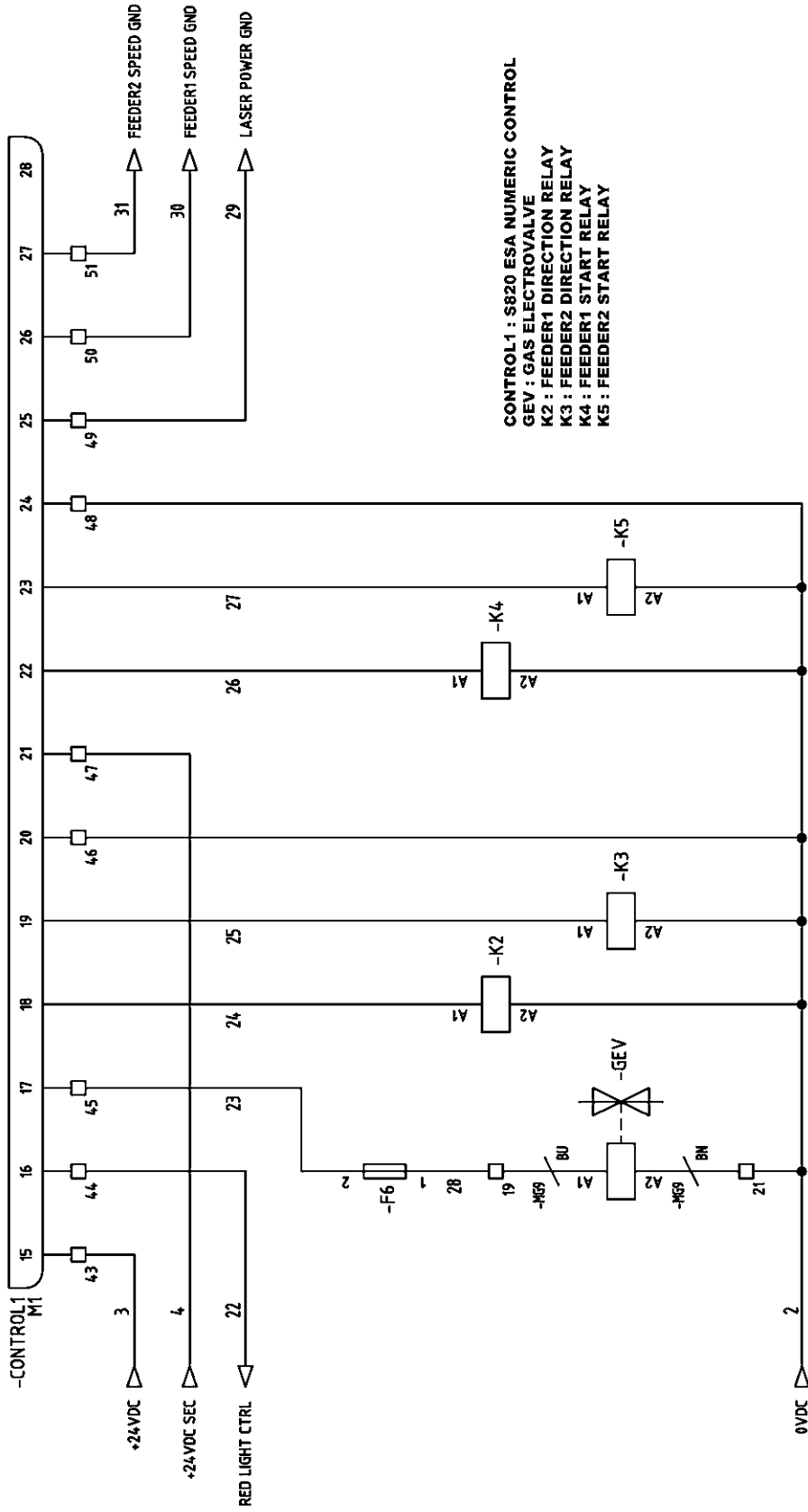

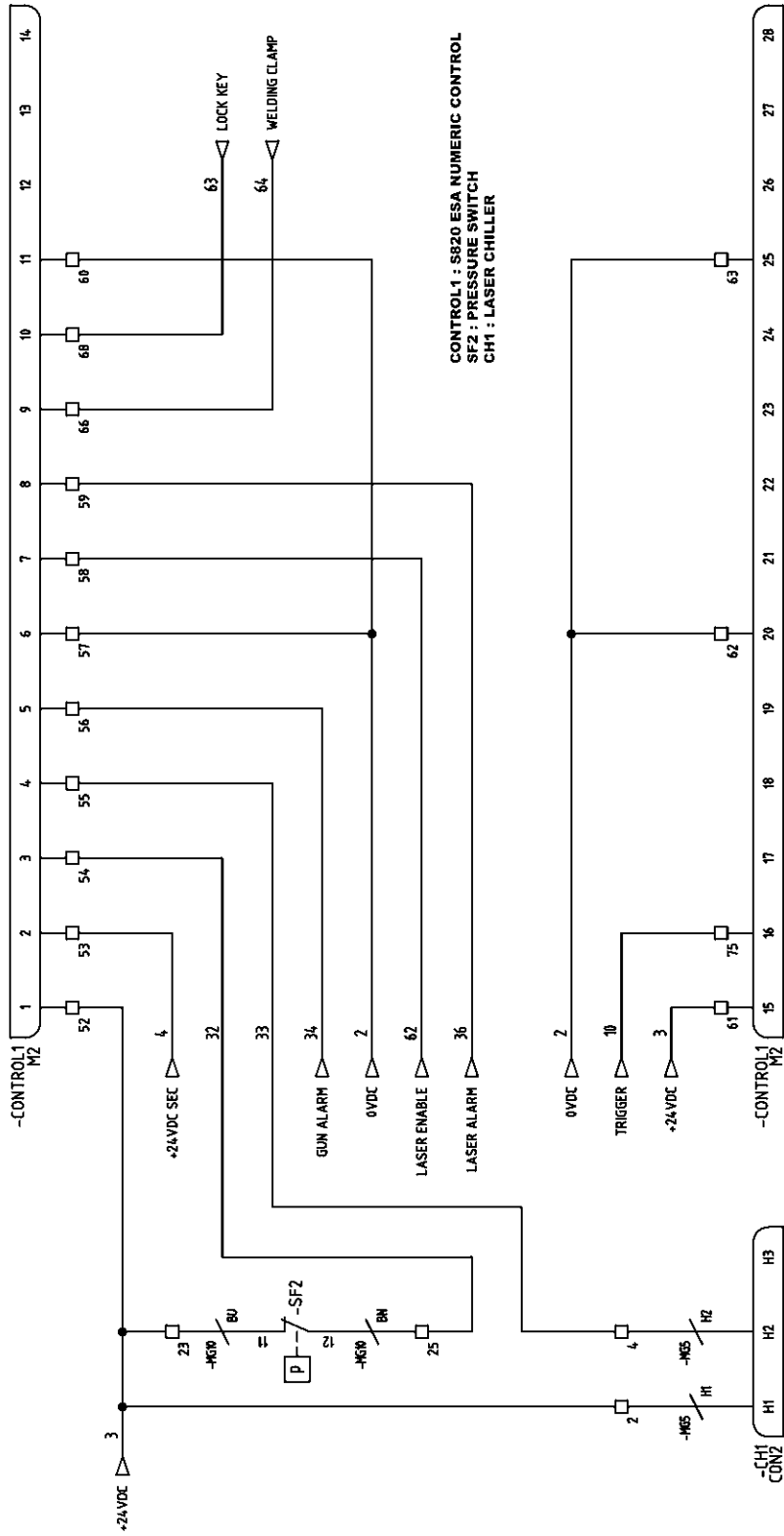

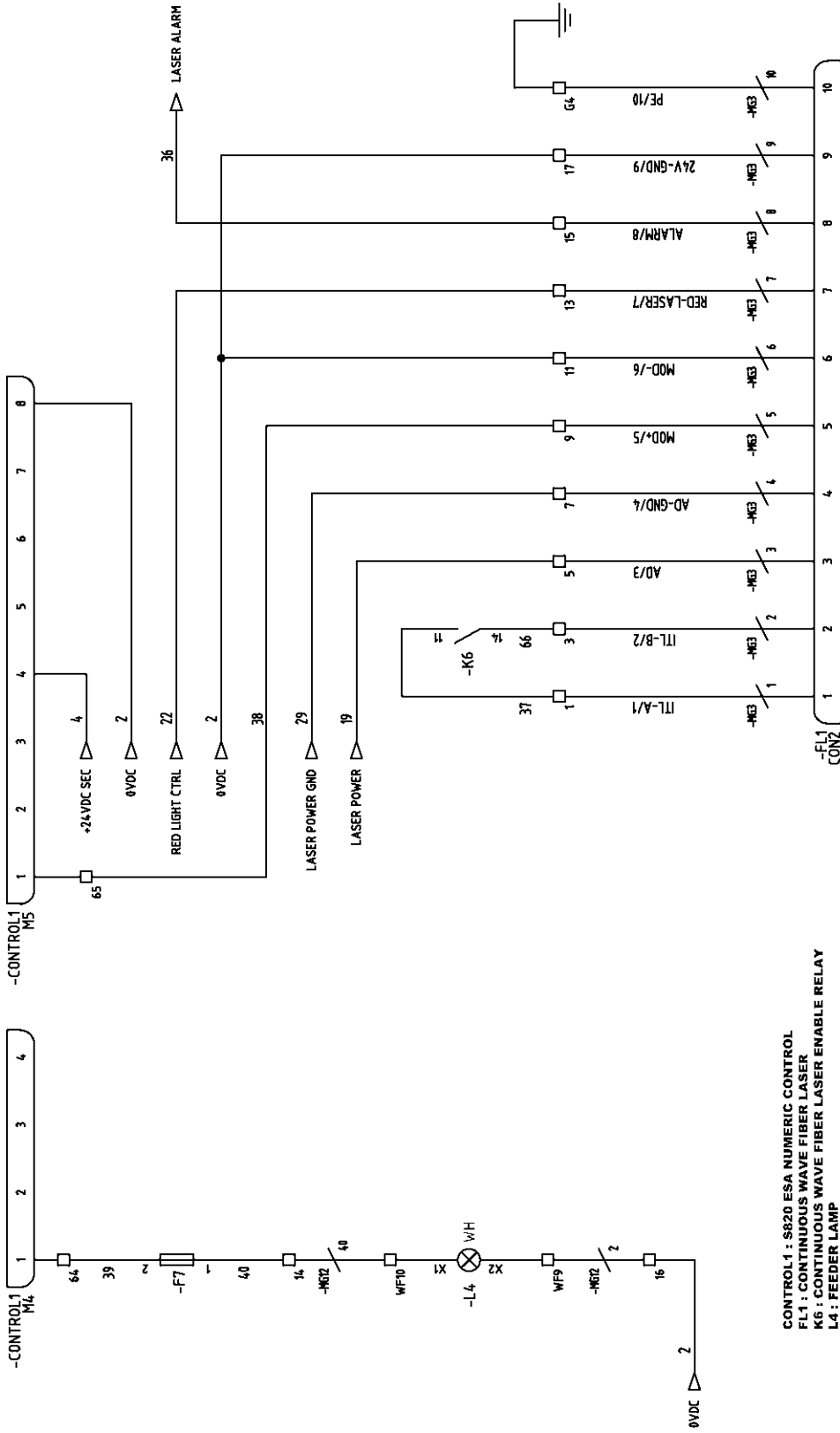

CONTROL 1 : S820 ESA NUMERIC CONTROL  
 FL1 : CONTINUOUS WAVE FIBER LASER  
 K6 : CONTINUOUS WAVE FIBER LASER ENABLE RELAY  
 L4 : FEEDER LAMP

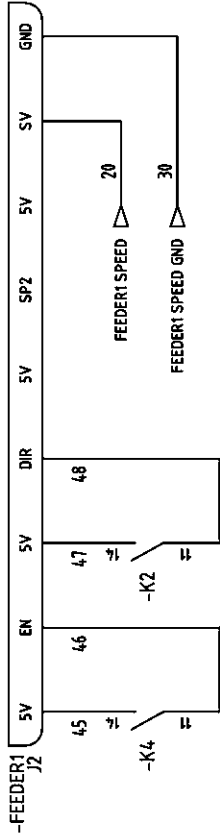

FEEDER1 : WIRE FEEDER 1 BOARD  
 FEEDER2 : WIRE FEEDER 2 BOARD  
 M1 : WIRE FEEDER 1 MOTOR  
 M2 : WIRE FEEDER 2 MOTOR  
 K2 : FEEDER1 DIRECTION RELAY  
 K3 : FEEDER2 DIRECTION RELAY  
 K4 : FEEDER1 START RELAY  
 K5 : FEEDER2 START RELAY

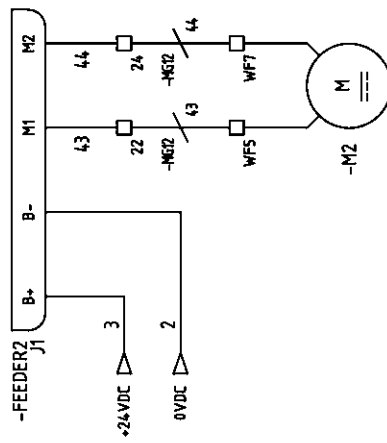
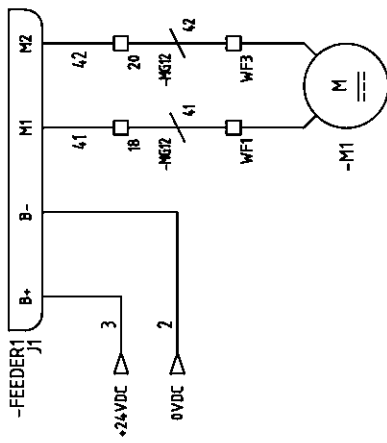
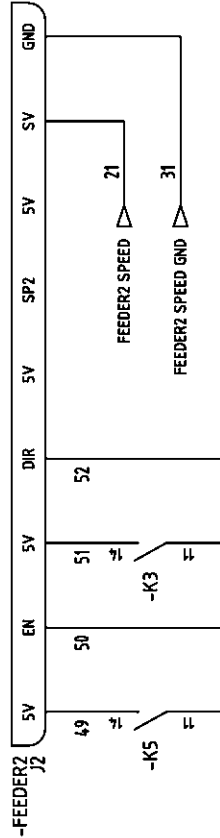

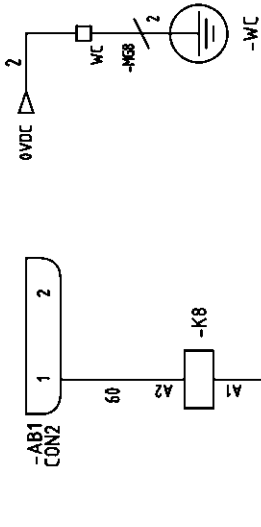
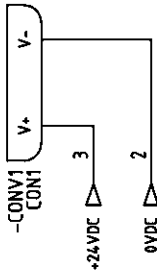
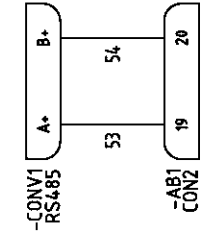

AB1 : ADAPTER BOARD  
 K8 : LASER WELDING CLAMP SAFETY RELAY  
 WC : LASER WELDING CLAMP  
 CONV1 : RS232 TO RS485 CONVERTER  
 LWH1 : LASER WELDING HEAD DRIVER  
 GUN : LASER GUN  
 CONTROL1 : S820 ESA NUMERIC CONTROL

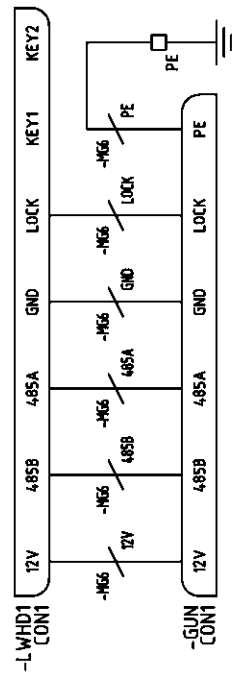
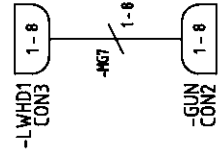
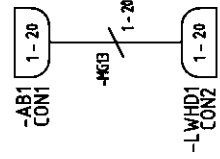
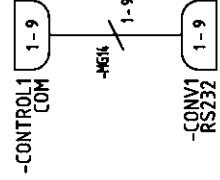
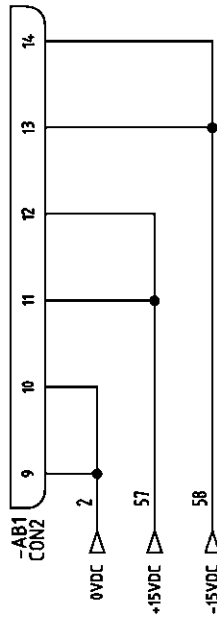
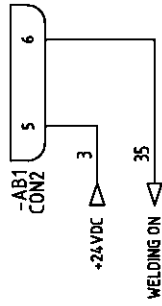
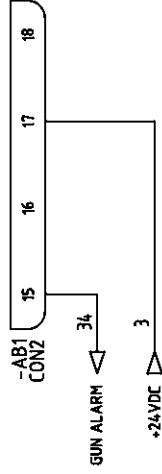

# OUR RANGE OF MACHINERY



IRON WORKERS



NON-MANDREL PIPE BENDERS



HORIZONTAL PRESS BRAKES



SECTION BENDING MACHINES



CNC PIPE BENDERS



LASER WELDING EQUIPMENTS



TWISTING/SCROLL BENDING MACHINES



HYDRAULIC PRESS BRAKES



HYDRAULIC SHEAR MACHINES



GAS FORGES



IRON EMBOSSING MACHINES



END WROUGHT IRON MACHINES



BROACHING MACHINES



POWER HAMMERS



BLACKSMITH FORGING PRESS