

**Set of embossing rollers
for 50 and 60 mm pipes**

Ref. 140-11-01-00503

NOA60

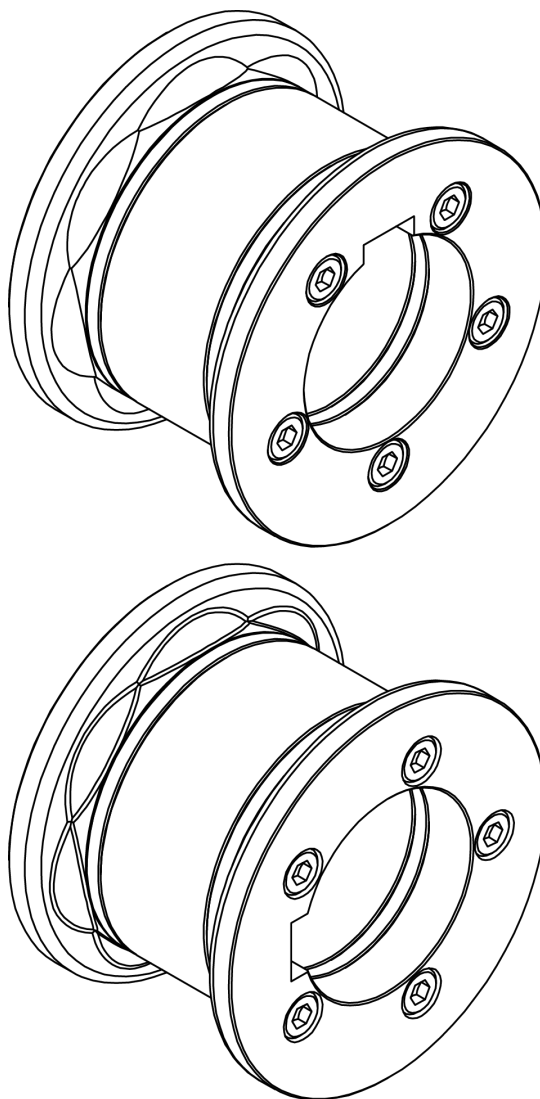

TECHNICAL FEATURES

PRADA NARGESA, S.L

Ctra. de Garrigàs a Sant Miquel s/n
17476 Palau de Santa Eulàlia (GIRONA) SPAIN
Tel. 972 568085 - nargesa@nargesa.com
www.nargesa.com

INDEX

1. Tooling description	3
2. Elements identification	4
2.1. Upper roller	4
2.2. Lower Roller	5
3. Rollers assembling	6
3.1. Rollers assembling for 50 mm pipe	6
3.2. Rollers assembling for 60 mm pipe	7
4. Our range of rollers for pipe embossing	8

1. Tooling description

- ▶ Set of embossing rollers for 50 and 60mm pipes

Ref: 140-11-01-00503

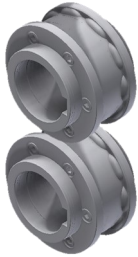

Set of sectioned rollers to emboss different square or rectangular pipe sizes with the same set. Adjustable to the following pipes:

Square pipes: 50mm or 60mm

Rectangular pipes: 50x20mm, 50x25mm, 50x30mm, 50x35mm, 50x40mm, 50x45mm, 60x20mm, 60x25mm, 60x30mm, 60x35mm, 60x40mm, 60x45mm, 60x50mm or 60x55mm

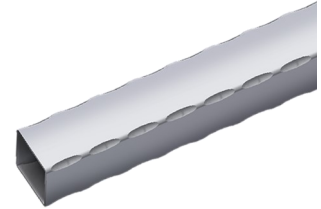

Guide 140-11-01-00505 or 140-11-01-00506 is required

Ask the manufacturer about different dimensions

Set per machine	Material minimum thickness suggested by manufacturer	Weight
1	3 mm	6 Kg

- ▶ Inlet guide for 50 mm pipe



Ref: 140-11-01-00505

Inlet guide for 50 mm pipe

Weight: 2,4 Kg

- ▶ Inlet guide for 60 mm pipe



Ref: 140-11-01-00506

Inlet guide for 60 mm pipe

Weight: 2,2 Kg

2. Elements identification

Sectioned rollers for pipe embossing have been designed to work on different pipe sizes with one only set of rollers.

2.1. Upper roller

IMPORTANT: In order to achieve a correct use of the machine, it is remarkably essential to place both fit spacer rings, one at each end of the embossing roller, so the total length of the set always remains 109mm.



HAZARD: Never surpass 109mm as maximum length

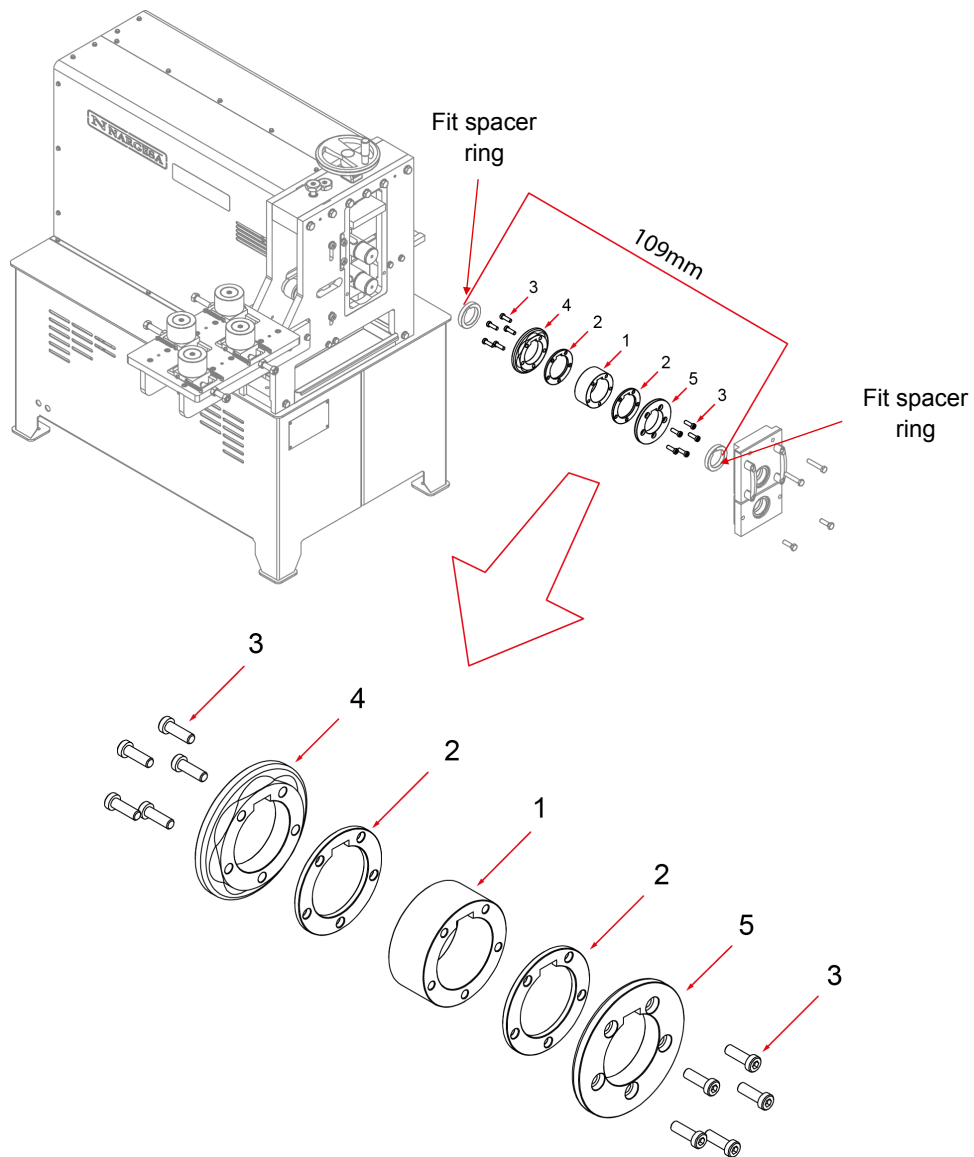

1	125-11-01-00003	SPACER 38 mm	1
2	125-11-01-00004	SPACER 5 mm	2
3	020-D6912-M8X25	ALLEN SMALL HEADED SCREW DIN 6912 M8X25	10
4	125-11-01-00001	LATERAL UPPER INNER ROLLER PIPE 50-60	1
5	125-11-01-00002	LATERAL UPPER OUTER ROLLER PIPE 50-60	1

2.2. Lower roller

IMPORTANT: In order to achieve a correct use of the machine, it is remarkably essential to place both fit spacer rings, one at each end of the embossing roller, so the total length of the set always remains 109mm.



HAZARD: Never surpass 109mm as maximum length

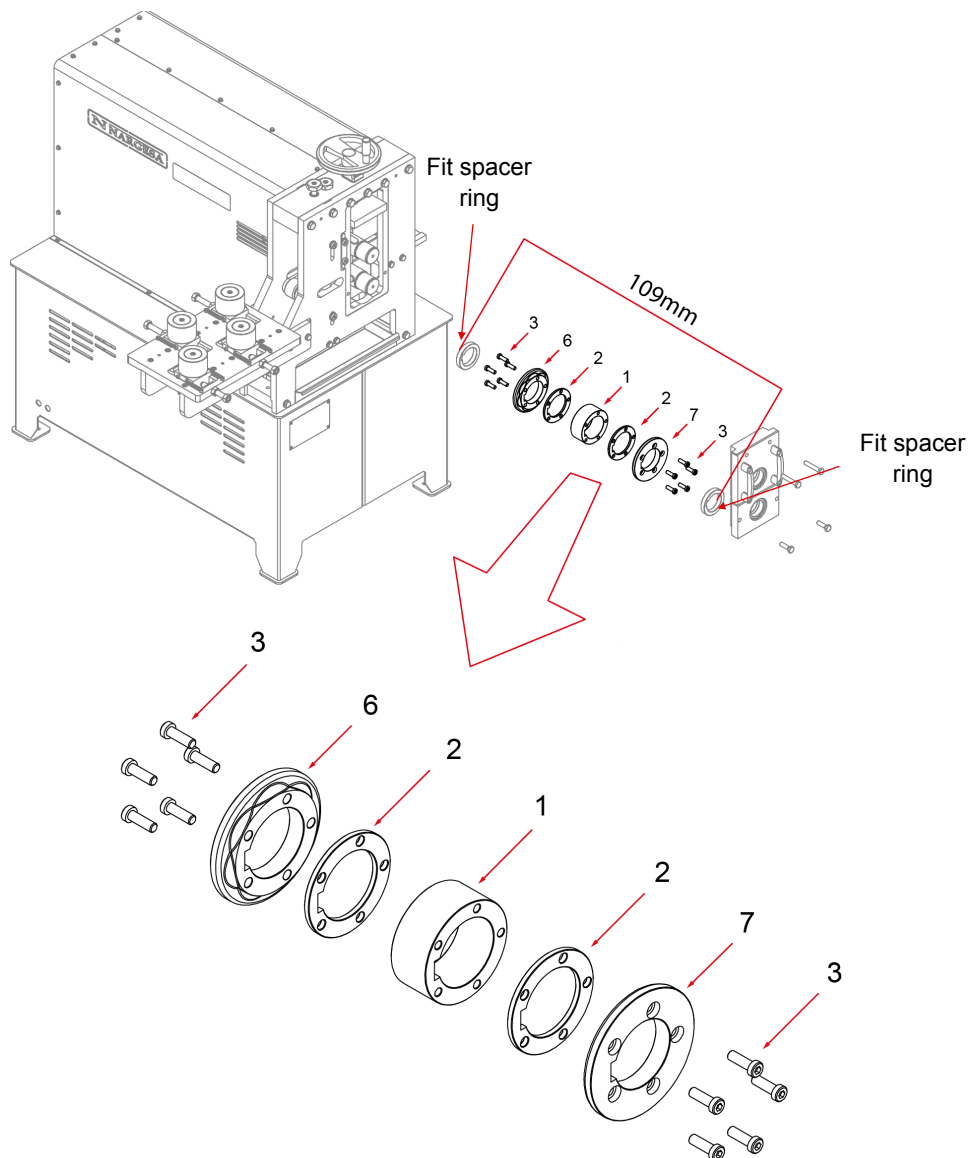

1	125-11-01-00003	SPACER 38 mm	1
2	125-11-01-00004	SPACER 5 mm	2
3	020-D6912-M8X25	ALLEN SMALL HEADED SCREW DIN 6912 M8X25	10
6	125-11-01-00018	LATERAL LOWER INNER ROLLER PIPE 50-60	1
7	125-11-01-00019	LATERAL LOWER OUTER ROLLER PIPE 50-60	1

3. Rollers assembling

We'll use the different rollers sections depending on the size of the pipe to be embossed.

Then we'll detail every element used for each pipe size, always including sections 4 and 5 (Upper roller) or 6 and 7 (Lower roller) to these sets, which are the ones to perform the embossing operation as such.

3.1. Rollers assembling for 50mm pipe

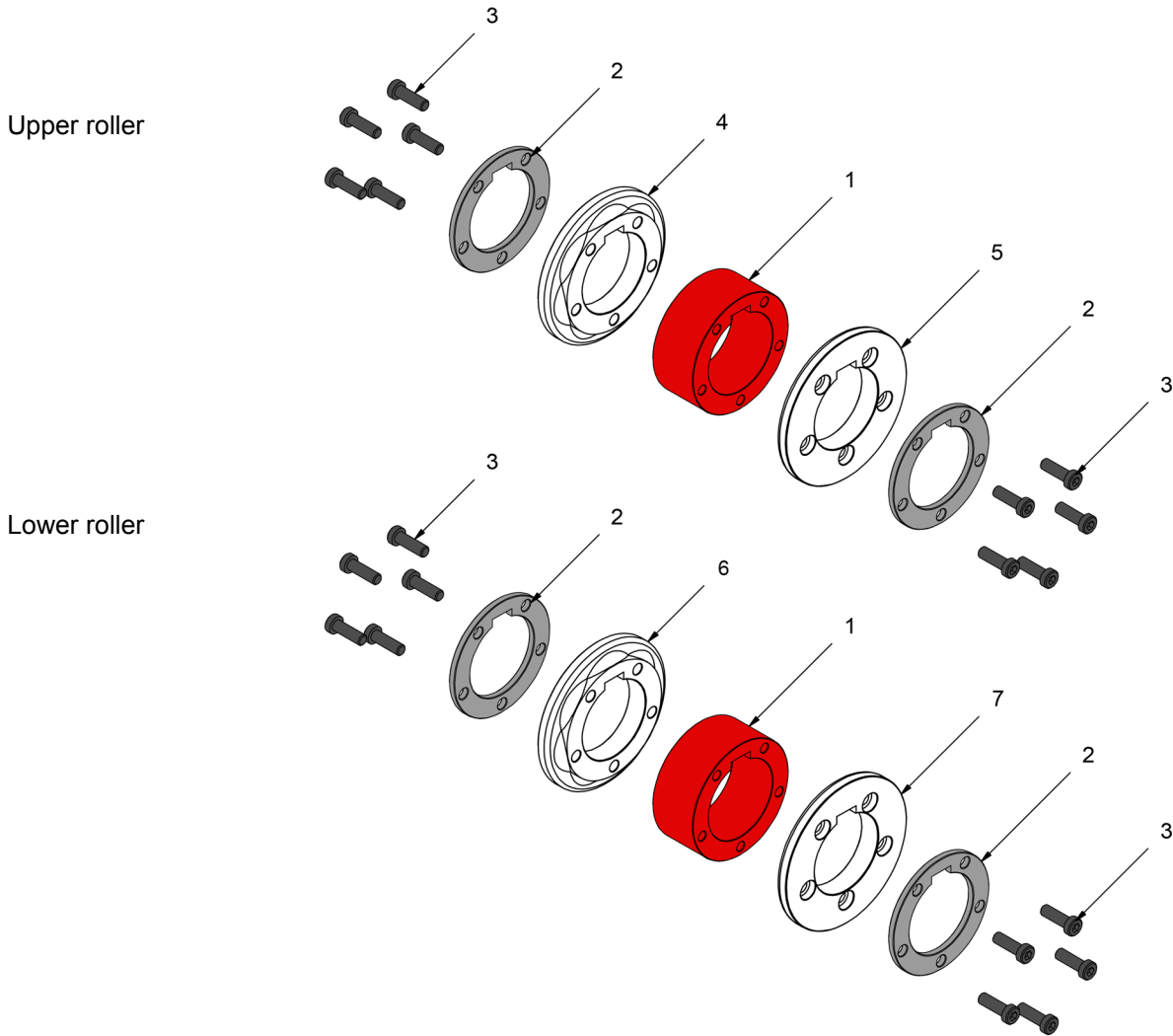

	INSIDE	1	125-11-01-00003	SPACER 38 mm
	EXTERIOR	2	125-11-01-00004	SPACER 5 mm
	SCREWS	3	020-D6912-M8X25	ALLEN SMALL HEADED SCREW DIN 6912 M8X25
		4	125-11-01-00001	LATERAL UPPER INNER ROLLER PIPE 50-60
		5	125-11-01-00002	LATERAL UPPER OUTER ROLLER PIPE 50-60
		6	125-11-01-00018	LATERAL LOWER INNER ROLLER PIPE 50-60
		7	125-11-01-00019	LATERAL LOWER OUTER ROLLER PIPE 50-60

3.2. Rollers assembling for 60mm pipe

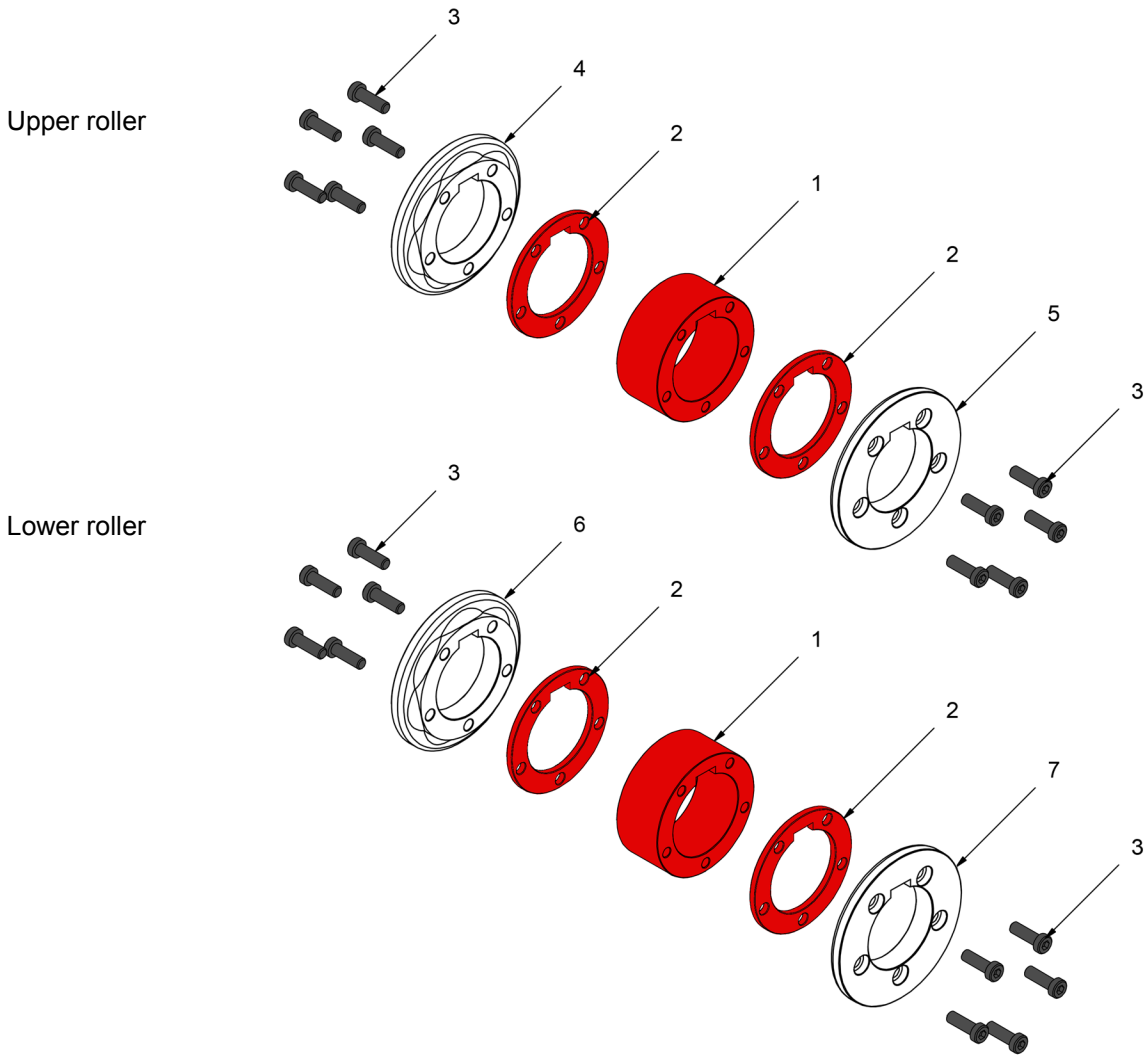

	INSIDE	1	125-11-01-00003	SPACER 38 mm
	INSIDE	2	125-11-01-00004	SPACER 5 mm
	SCREWS	3	020-D6912-M8X25	ALLEN SMALL HEADED SCREW DIN 6912 M8X25
		4	125-11-01-00001	LATERAL UPPER INNER ROLLER PIPE 50-60
		5	125-11-01-00002	LATERAL UPPER OUTER ROLLER PIPE 50-60
		6	125-11-01-00018	LATERAL LOWER INNER ROLLER PIPE 50-60
		7	125-11-01-00019	LATERAL LOWER OUTER ROLLER PIPE 50-60

4. Our range of rollers for pipe embossing

- ▶ Set of embossing rollers for 25 mm or 1", 30 mm or 1" 1/4, 35 and 40 mm pipes



Ref: 140-11-01-00500

Set of sectioned rollers to emboss different square or rectangular pipe sizes with the same set. Adjustable to the following pipes:

Square pipes: 25mm or 1", 30mm or 1" 1/4, 35 and 40mm

Rectangular pipes: 25x20mm or 1"x3/4", 30x20mm or 1"1/4x3/4", 30x25mm, 35x20mm, 35x25mm, 40x20mm, 40x25mm, 40x30mm, 40x35mm

Guide 140-11-01-00501 or 140-11-01-00502 is required

Ask the manufacturer about different dimensions

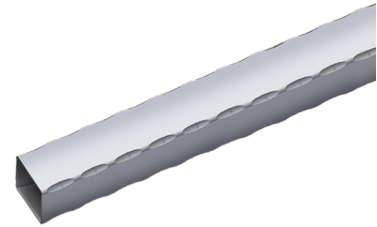

Set per machine	Material minimum thickness suggested by manufaturer	Weight
1	3 mm	12 Kg

- ▶ Inlet guide for 25 mm or 1" and 30 mm or 1" 1/4 Pipe

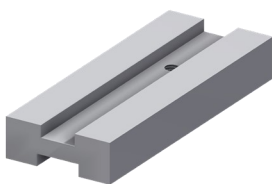

Ref: 140-11-01-00501

Inlet guide for 25 mm or 1" and 30 mm or 1" 1/4 pipe
Weight: 3 Kg

- ▶ Inlet guide for 35 and 40 mm pipe

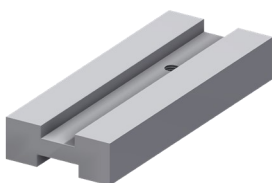

Ref: 140-11-01-00502

Inlet guide for 35 and 40 mm pipe
Weight: 2,8 Kg

- ▶ Set of embossing rollers for 1" 1/2, 2" and 2" 1/2 inches pipes

Ref: 140-11-01-00507

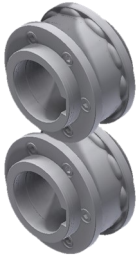

Set of sectioned rollers to emboss different square or rectangular pipe sizes with the same set. Adjustable to the following pipes:

Square pipes: 1" 1/2, 2" and 2" 1/2 inches

Rectangular pipes: 1"1/2x3/4", 1"1/2x1", 2"x1", 2"x1"1/4, 2"x1"1/2, 2"1/2x1"1/2 inches

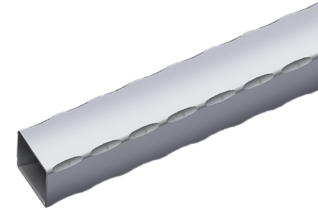

Guide 140-11-01-00508, 140-11-01-00509 or 140-11-01-00510 is required

Ask the manufacturer about different dimensions

Set per machine	Material minimum thickness suggested by manufacturer	Weight
1	3 mm	6 Kg

- ▶ Inlet guide for 1" 1/2 inches pipe



Ref: 140-11-01-00508

Inlet guide for 1" 1/2 inches pipe

Weight: 2,6 Kg

- ▶ Inlet guide for 2" inches pipe



Ref: 140-11-01-00509

Inlet guide for 2" inches pipe

Weight: 2,4 Kg

- ▶ Inlet guide for 2" 1/2 inches pipe



Ref: 140-11-01-00510

Inlet guide for 2" 1/2 inches pipe

Weight: 2,2 Kg