

# **GAS FORGE**

---

## **H3**

NS: 2021-180

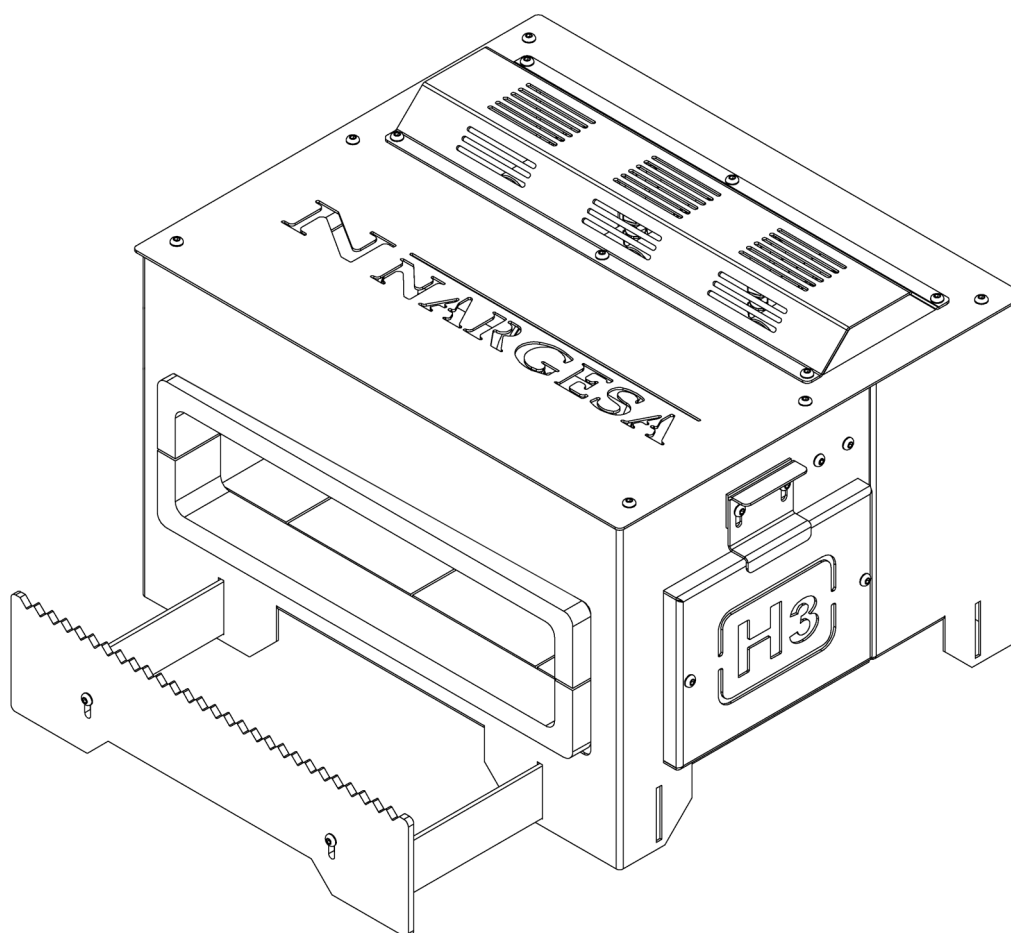

## **INSTRUCTIONS BOOK**

---

**PRADA NARGESA, S.L**

Ctra. de Garrigàs a Sant Miquel s/n · 17476 Palau de Santa Eulàlia (Girona) Spain  
Tel. +34 972568085 · [nargesa@nargesa.com](mailto:nargesa@nargesa.com) · [www.nargesa.com](http://www.nargesa.com)

Thank you for choosing our machines



[www.nargesa.com](http://www.nargesa.com)

## INDEX

<b>1. MACHINE INFORMATION</b>	3
1.1. Identification of the machine	3
1.2. Dimensions	3
1.3. Description of the machine	3
1.4. Fuel for the furnace	4
1.5. Identification of elements	5
1.6. Description of elements	6
1.6.1. Openings	6
1.6.2. Burners	6
1.6.3. Thermocouple	7
1.7. General Features	8
<b>2. TRANSPORT AND STORAGE</b>	9
2.1. Transport	9
2.2. Storage conditions	9
<b>3. MAINTENANCE</b>	10
3.1. General maintenance	10
3.2. Change of the insulating material of the furnace	11
<b>4. HANDLING BOOK</b>	16
4.1. Gas valve	16
4.2. Pushbuttons	16
4.3. Pressure controller and manometer	16
<b>5. INSTALLATION AND SET UP</b>	17
5.1. Location of th machine	17
5.2. Dimensions and work área	17
5.3. Admissible external conditions	17
5.4. Set up	18
5.5. Openings	18
5.6. Adjustment of the material support position	19
5.7. First set up of furnace	20
5.8. Ignition of the furnace	22
5.9. Shutdown of the furnace	22
<b>6. POSSIBLE BREAKDOWNS</b>	23
<b>7. WARNINGS</b>	24
7.1. Hazard wastes	24
7.2. Protection elements for the operator	24

## TECHNICAL ANNEX

## 1. MACHINE INFORMATION

### 1.1. Identification of the machine

<b>Brand</b>	NARGESA
<b>Type</b>	Furnace
<b>Model</b>	H3

### 1.2. Dimensions

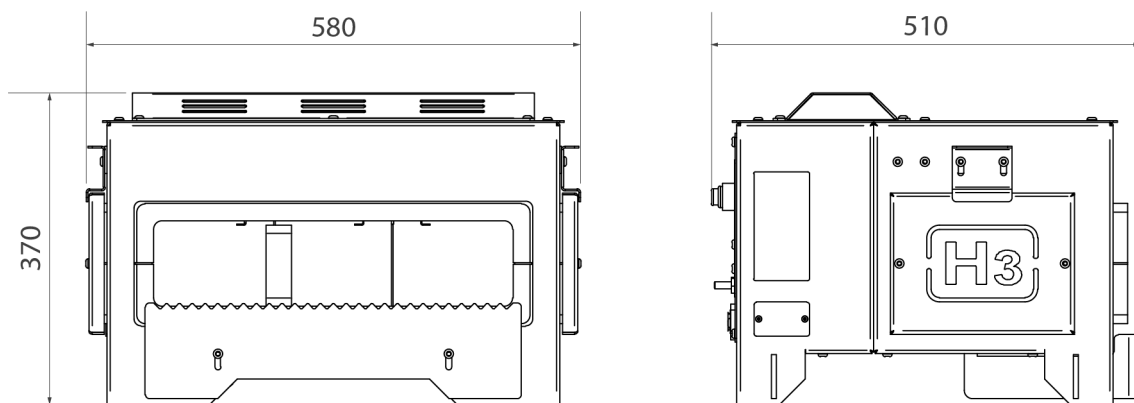

*Picture 1. External dimensions of the Furnace H3*

### 1.3. Machine description.

The H3 Furnace is an oven designed to heat metal profiles of different thicknesses and shapes. The furnace H3 allows us to heat parts up to a temperature of 1300°C.

The oven is composed of three elements (supplied by Nargesa): the oven, the **Gas hose** and the **Pressure regulator**. This type of installation will never be modified, in No Case.

The oven is equipped with three **Burners** for propane gas (LPG), independent.

The ignition of the oven is electronic.

The ovens designed and manufactured in Nargesa comply with the regulations in force in Spain, concerning to the Regulation of appliances that use gas as fuel RD919 / 2006.

#### 1.4. Fuel to be used with this foerge

##### COMPOSITION AND INFORMATION: PROPANE GAS G.L.P.

Chemical nature	Blend of Hydrocarbones
Synonyms	Gas de cocina - Gas licuado de petróleo
Ingredients	Propane Butane Ethane Penthane

##### IDENTIFICATION OF HAZARDS

###### Main hazards

Physical and chemical hazards	Flammable gas
Specific hazards	Suffocating and flammable gas
<b>Product effects</b>	
Adverse effects on human health	Suffocating product
Major Synthoms	Inhalation may cause dizziness.

##### MEASURES TO FIGHT FIRES

Proper fire extintion means	Water mist, chemical dust and carbón dioxide (CO2).
Specific hazards	It could be lit with heat, sparks or flsmess. Steams could travel up to the ignition source and return like flames. Keep out of container tanks.
Special methods	Remove containers from the fire zone, if this could be a riskless fact. Spray with wáter mist the containers exposed to fire. This devide should be remotely controlled, and so after the fire extintion. Fight the fire aains the wind direction, whenever it is posible. Do not extinguish fire before stopping the leak. In case the fire is intense in loaded areas, use hoses with holders to be used remotedly. Then if thi could not be done, just leave the área and let it burn.
Special Protection to fight against fires.	In closed places, use complete protection against fire and autonomous equipment to protect the respiratory tract.

**WARNING!**  
Consult your supplier's gas safety data card, before its use.  
Strictly follow your supplier's safety protocols.

1.5. Identificación de los elementos

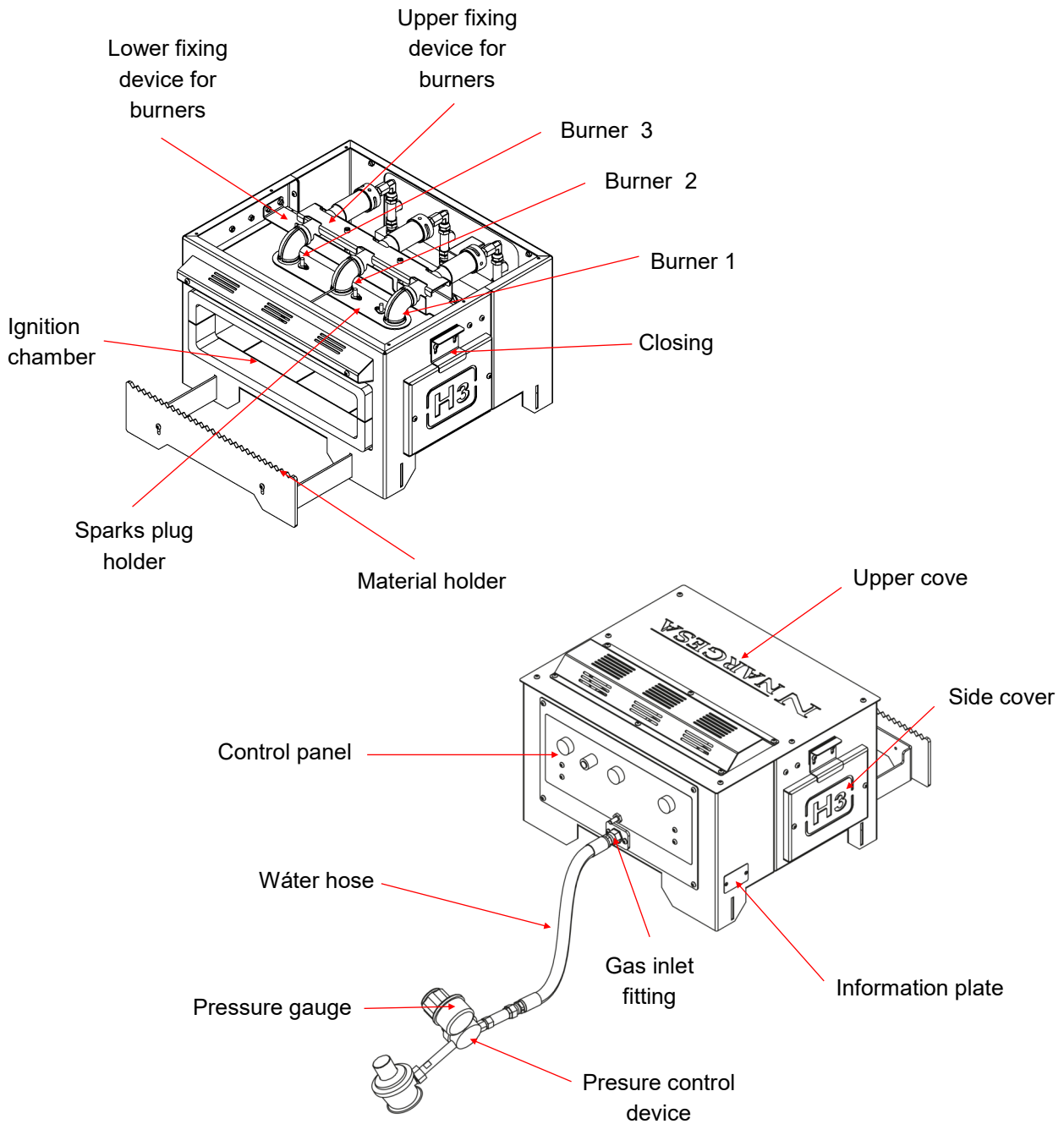

The **Adapter** for the gas bottle is NOT provided along with the furnace because of the major differences according to each country.

The Adapter must be equipped with a male thread 21,8 left.

Adapter

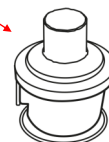

## 1.6. Description of elements

### 1.6.1. Openings

The furnace has three openings:

- The front opening is the one usually used, since it is the widest.
- Side openings are used to heat longer bars. If we want to heat a larger length of bar we will open only a lateral opening. If we want to heat an intermediate part of the bar we will open the two lateral openings of the oven so that the bar can pass through the inside of the oven and thus be able to heat the desired part

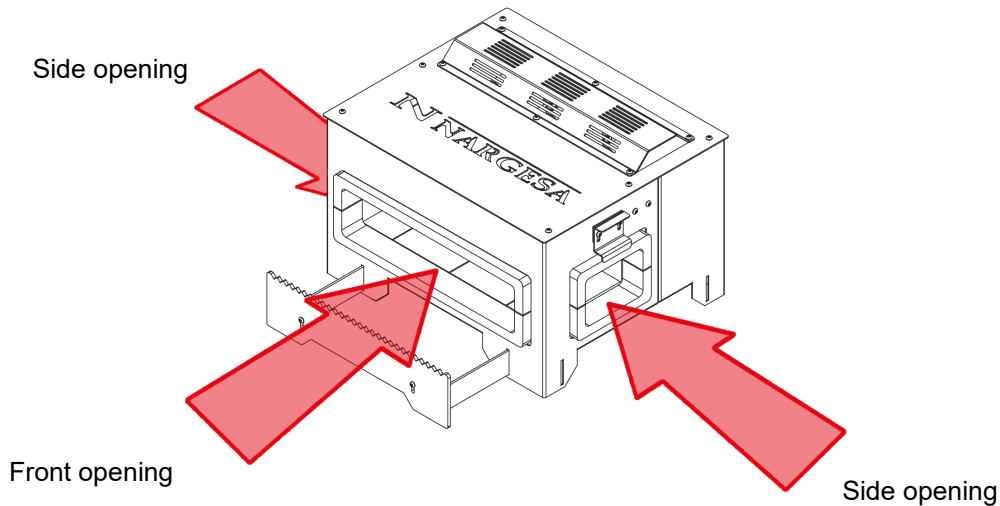

Picture 2. Furnace openings

### 1.6.2. Burners

The burners of Nargesa's Furnaces has been manufactured by Nargesa and designed exclusively to be used on the furnaces H1, H2 and H3.

- Type of burner: Atmospheric
- Maximum supply pressure: 1,5 Bar
- Fuel: Propane gas GLP
- Power: 4 Kw

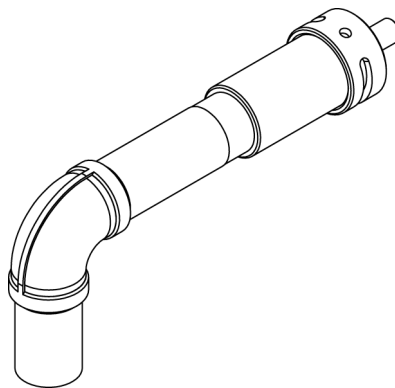

Picture 3. Furnace burner

### 1.6.3. Thermocouple

The thermocouple is the sensor to measure the temperature. It consists of two different metals, joined at one end. When the union of the two metals is heated or cooled, it produces a voltage proportional to the temperature which causes the safety valve to open or close.

The thermocouple safety valve consists of two parts: The valve and the thermocouple

The valve is equipped with the **Thermocouple pushbutton** for ignition of the furnace.

In the process of ignition of the furnace we press this button to allow the passage of gas. When the thermocouple gets enough temperature, we will release this pushbutton and the gas will continue to pass through the valve. This valve will remain open while the oven is in operation and the thermocouple will keep the working temperature.

Once the oven is switched off, and in a time interval of less than 2 minutes, the thermocouple cools and stops acting on the closing safety valve, thus preventing the passage of gas

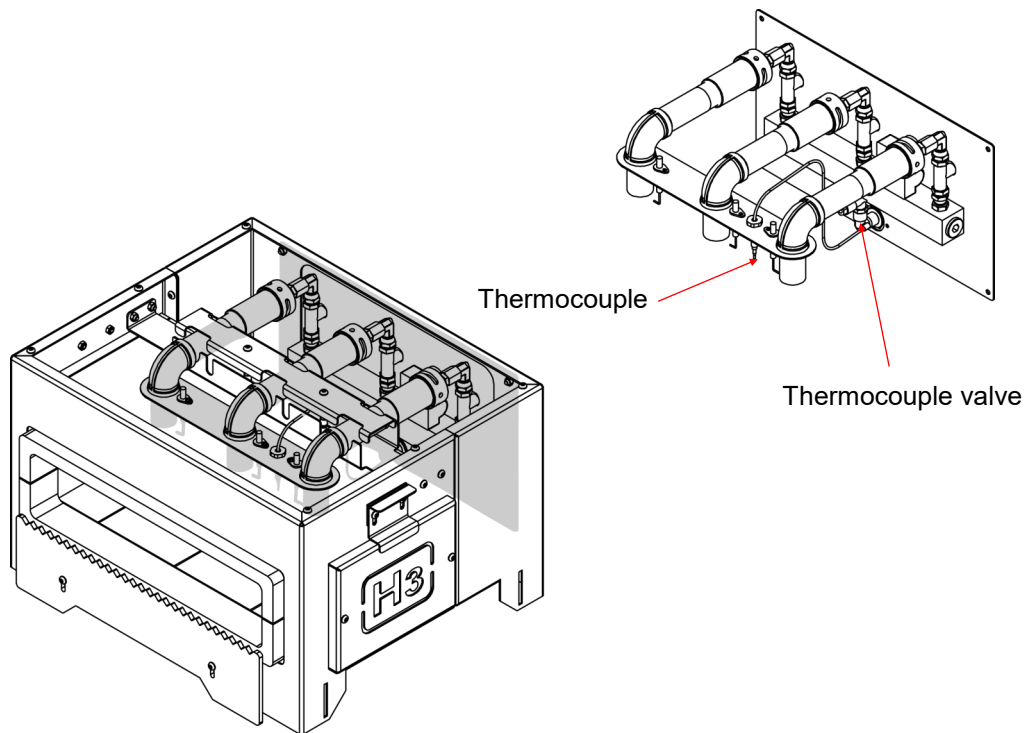

Picture 4. Thermocouple set



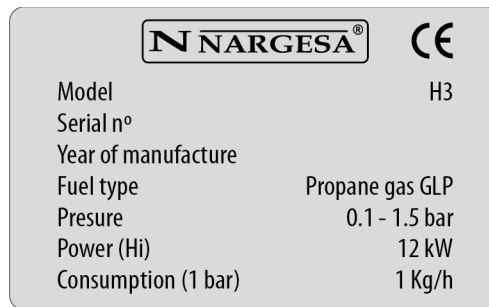

Picture 5. Information plate

### 1.7. Main features

Dimensions of combustion chamber	464x240x100 mm
Maximum temperature	1300 °C
Nr of burners	3
Type of fuel	Propane gas (GLP)
Adjustable working pressure	0.1-1.5 bar
Power (Hi)	12 kW
Gas intake as 1 per bar	1 Kg/h
External dimensions	510x580x370 mm
Weight	53 Kg

## 2. TRANSPORT AND STORAGE

### 2.1. Transport

Carrying of the furnace must be done by two people, holding it by the lower side of it and lifting it with both hands.

Do not transport the furnace in any other way since it could be damaged.

**WARNING:**

In order to move the gadget it is necessary that all burners are OFF and wait 24 hours to make sure the isolating material is at room temperature.

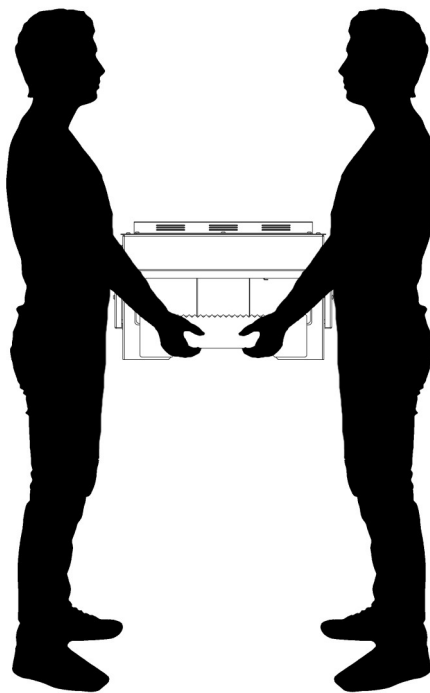

*Picture 6. Transport of the machine*

### 2.2. Storage conditions

The furnace cannot be stowed in a place that does not meet the following requirements:

- Humidity between 30% and 95%
- Temperature from -25 to 55°C or 75°C for periods not exceeding 24 hours 24h (keep in mind these temperatures are for storage conditions)
- Do not pile machines or any other objects on top of it.
- Do not dismantle for stowing

### 3. MAINTENANCE

#### 3.1. General Maintenance

- It is recommended to keep the **Combustion chamber** clean, as far as possible, to ensure proper operation and thus prolong the useful life of the insulating material.
- It is recommended to check the status of the thermocouple, the ignition device, the gas valve, the regulator and the non-return valve. If any of these elements suffers any type of deterioration, contact the Nargesa technical service.
- It is required the replacement of the thermocouple, the ignition device, the gas valve, the regulator and the non-return valve every 5 years.
- It is recommended to replace the insulating material every 2000 hours of operation.

#### WARNING:

To proceed with the maintenance of the oven it is necessary to turn off the **Burners** and wait 24 hours to ensure that all the components are at ambient temperature.

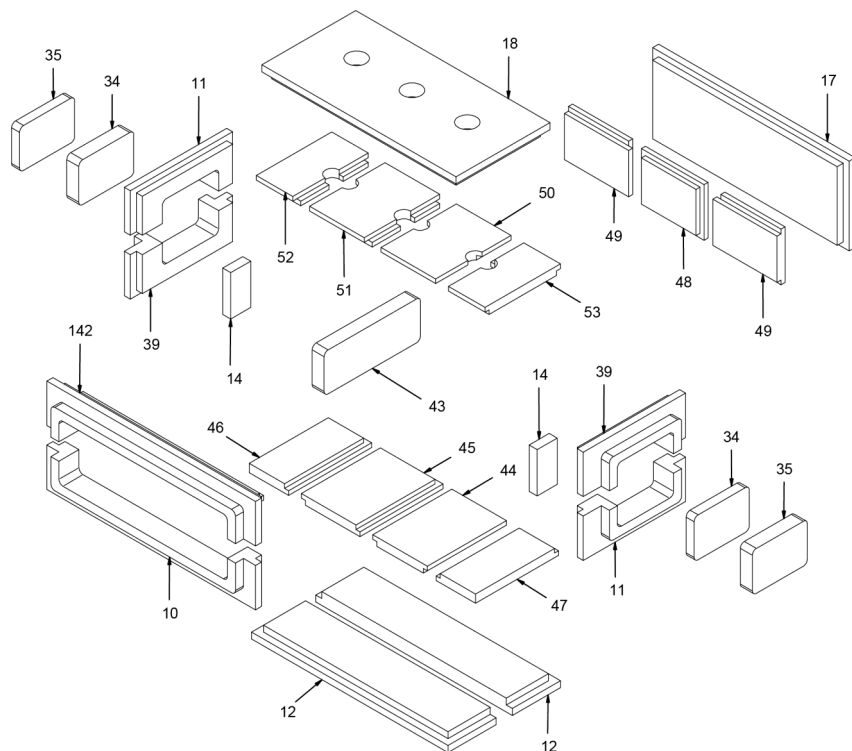

Picture 7. Insulating kit

### 3.2. Change of the insulating material of the oven

To remove the insulating material from the oven we will follow the following instructions:

**WARNING:**

To proceed with the change of insulating material it is necessary to turn off the **Burners** and wait 24 hours to ensure that the insulating material is at room temperature

1. Disconnect the gas bottle from the oven.

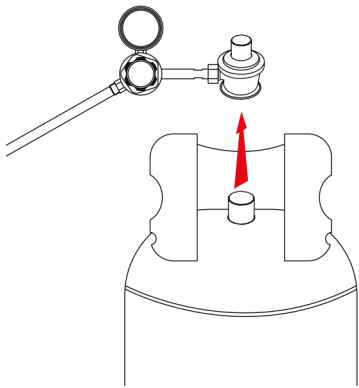

2. Disconnect the **Gas hose** from the **Inlet fitting**

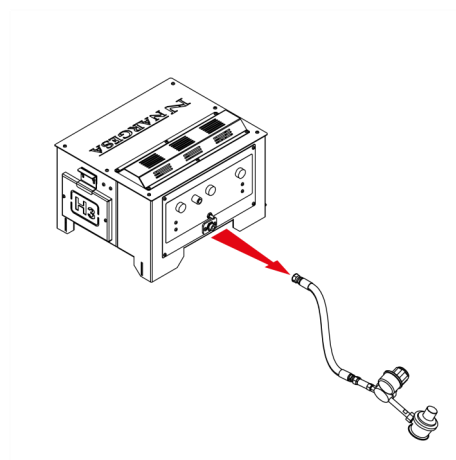

3. Remove the **Upper cover** by unscrewing the six bolts.

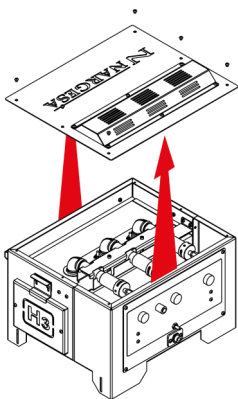

4. Remove the **Upper setting** of the burners

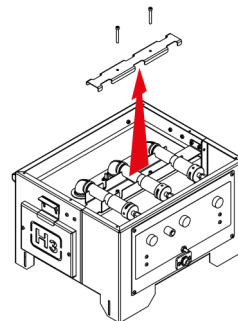

5. Remove the thermocouple and the spark plugs by pull away the three bolts

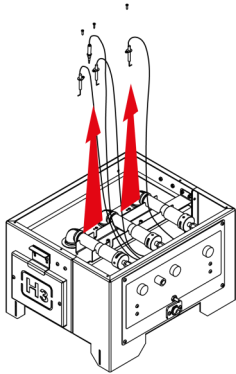

6. Take off the 4 bolts and nuts that hold the **Control Panel**. Remove the **Control panel**, the thermocouple and the spark plugs

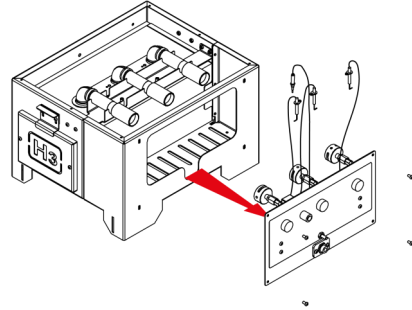

7. Remove the two **Burners** and the **Spark plugs holders**

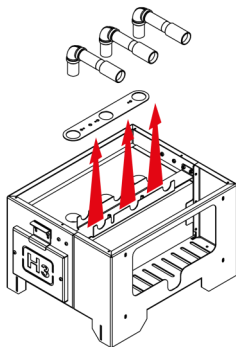

8. Dismantle the **Lower fixing of the burners** by unscrewing the four bolts and the four nuts that hold it.

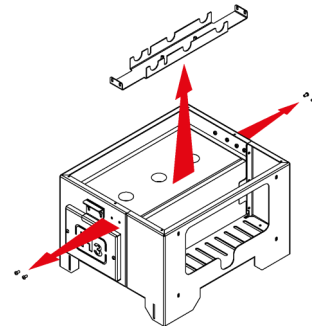

9. Remove the **Side doors** following the instructions on Section 5.5

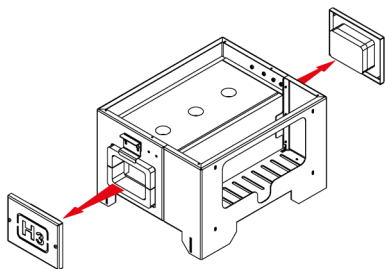

10. Take off the insulation upper plates.

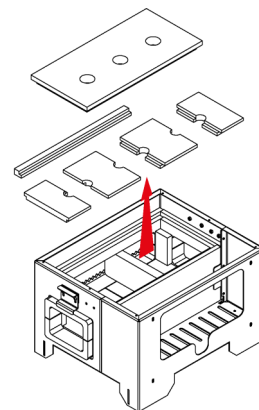

11. Remove the rear insulation panels

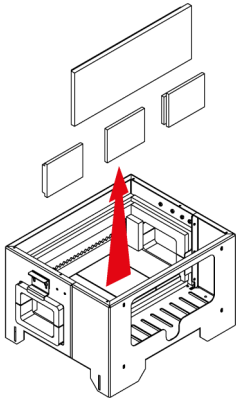

12. Remove the front holders of the upper plate

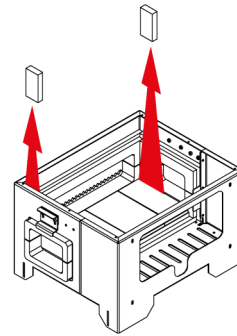

13. Remove the lower insulation

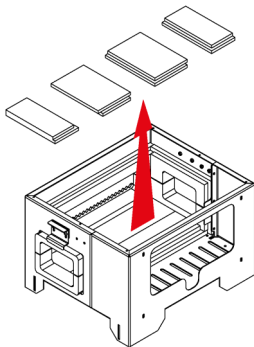

14. Slide the lower insulation towards the back part of the furnace and remove them by the upper side.

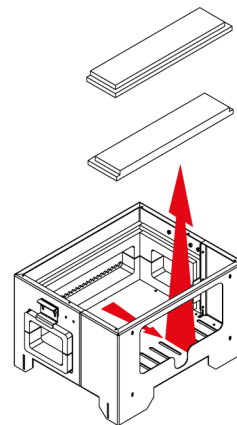

15. Remove the side insulations

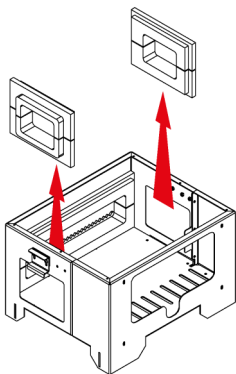

16. Remove the front insulations

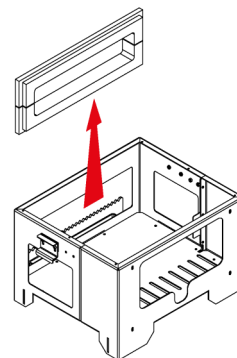

We will use this process in reverse order to do the placement of the insulation:

1. Place the front insulation

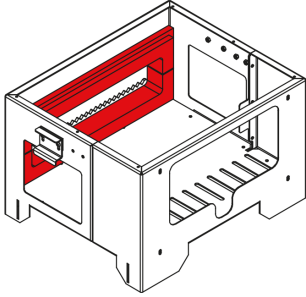

2. Place the side insulation

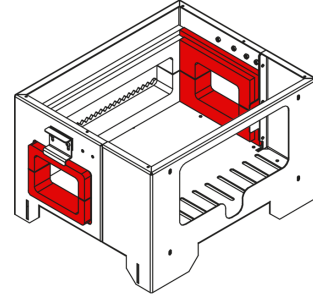

3. Place the lower insulation by the upper/ rear side of the furnace and slide them towards the front part.

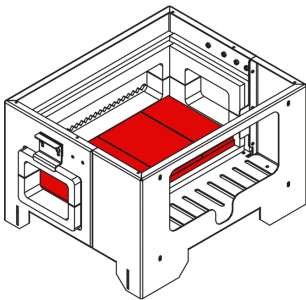

4. Place the front holders of the upper plate

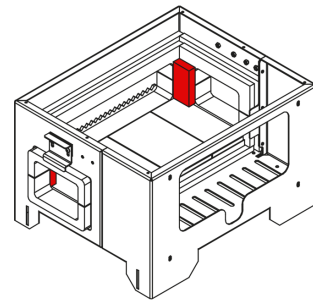

5. Place the rear insulation

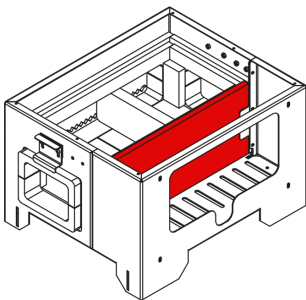

6. Put the insulation upper plates

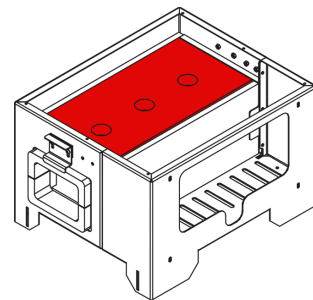

7. Place the **Side doors**. Assemble the **Lower fastener of the burners** by tightening the four screws and the four nuts that hold it

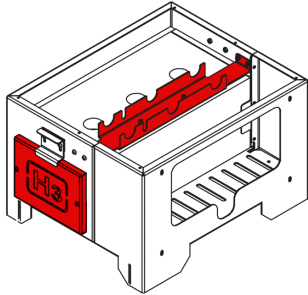

8. Place the **Spark plug holder** and the three **burners** adjusting the **Lower burner fixer** so that the end of the **Burner** is aligned with the

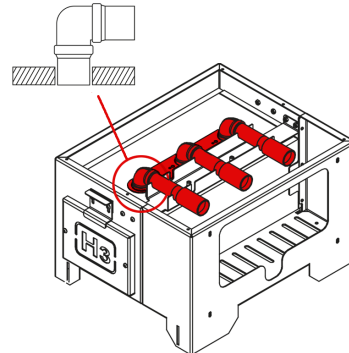

9. Place the **Control panel**, the thermocouple and the spark plugs by fixing the bolts and nuts.

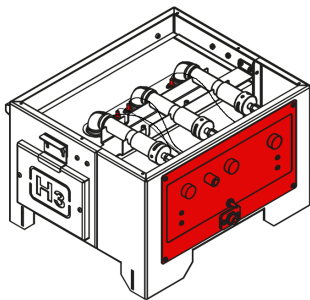

10. Mount the **Upper fixer of the burners**

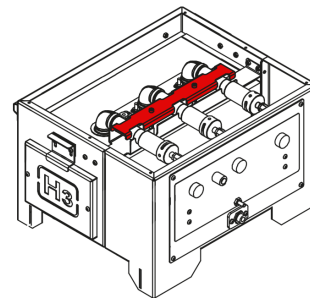

11. Place the **Upper cover** by fixing the 6 bolts

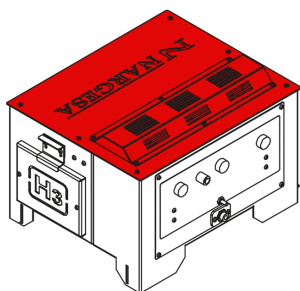

12. Connect the **Gas Hose** to the **Inlet racor**

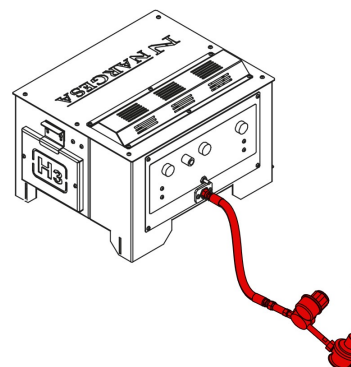



#### 4. HANDLING MANUAL

We have a **Control panel** which will allow us to control the performance of the furnace H3 and which will enable us to maintain complete control of the machine in a simple and intuitive way.

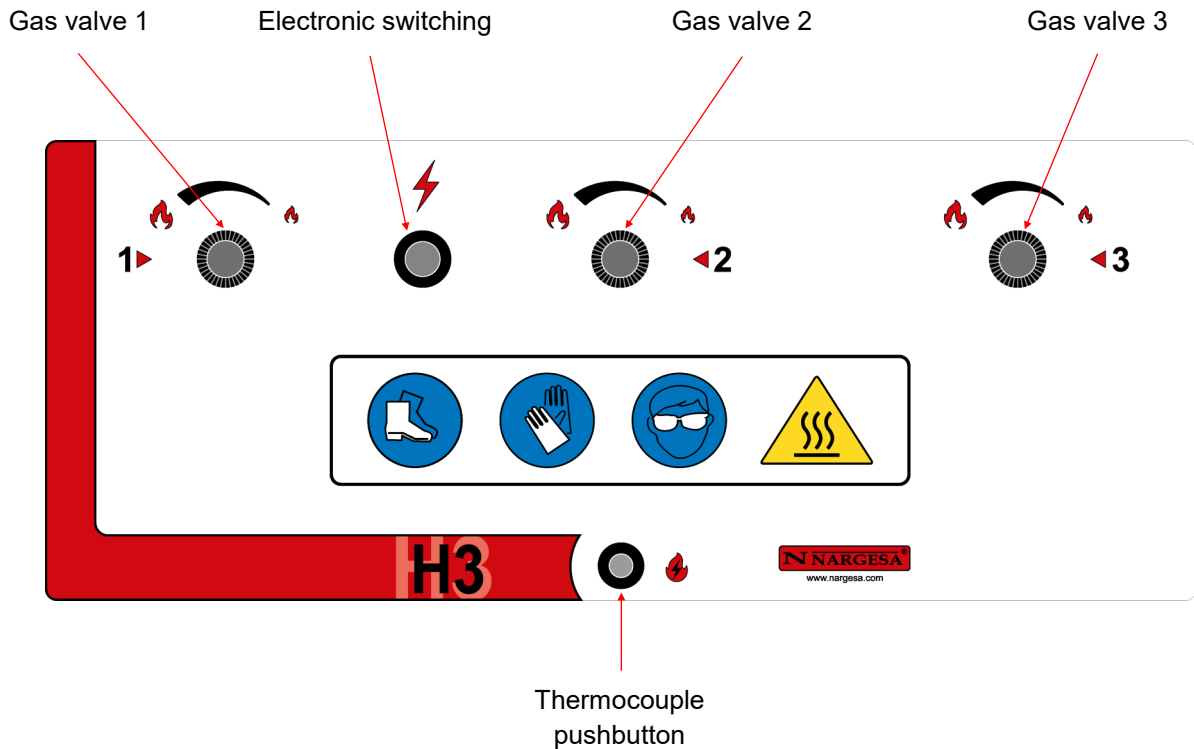

##### 4.1. Gas valve

The **Control panel** has got three valve for the opening of the gas entrance to the **Burners**. These valves are marked with numbers 1, 2 and 3 the operator controls them in order to obtain more or less gas flow.

##### 4.2. Pushbuttons

There are two pushbuttons in the **Control panel**:

- The pushbutton for **Electronic switching** is the one that activates the spark plug and generates the spark to light up the **Burner**.
- The **Thermocouple pushbutton** is the one that opens the valve to get the thermocouple activated. This valve opens the path to the **Gas valves (1, 2, 3)**

##### 4.3. Pressure regulator and manometer

The **Pressure regulator** allows us to control the working pressure between 0,1 and 1,5 bar, Nargesa suggests to work at a pressure from 0,2 to 1 bar. The **Manometer** will indicate the pressure value on the furnace circuit.

## 5. INSTALLATION AND SET UP

### 5.1. Machine location

The aim is to locate the furnace properly to avoid having to move it; otherwise, the user must follow the guidelines described in the transport section (n°2). It should be placed on a smooth and levelled surface to avoid any movement of it during the positioning of the profiles.

### 5.2. Dimensions y work area

When the furnace is placed, its dimensions, the safety zone, the work area of the operator and the possible lengths of the workpiece will be taken into account.

Safety zone: We will place the furnace in a zone free of elements and objects, following the indications of the following figure.

The oven will be installed in accordance with the regulations in force and will be used only in sufficiently ventilated places.

The oven can be used by a single operator, which must be work frontally or laterally to the machine to be able to handle the piece safely.

Before starting the heating of the pieces, with the **Burners** off, the operator will adjust the **material support**, adapting it to the material profile and its length, as indicated in section 5.6.

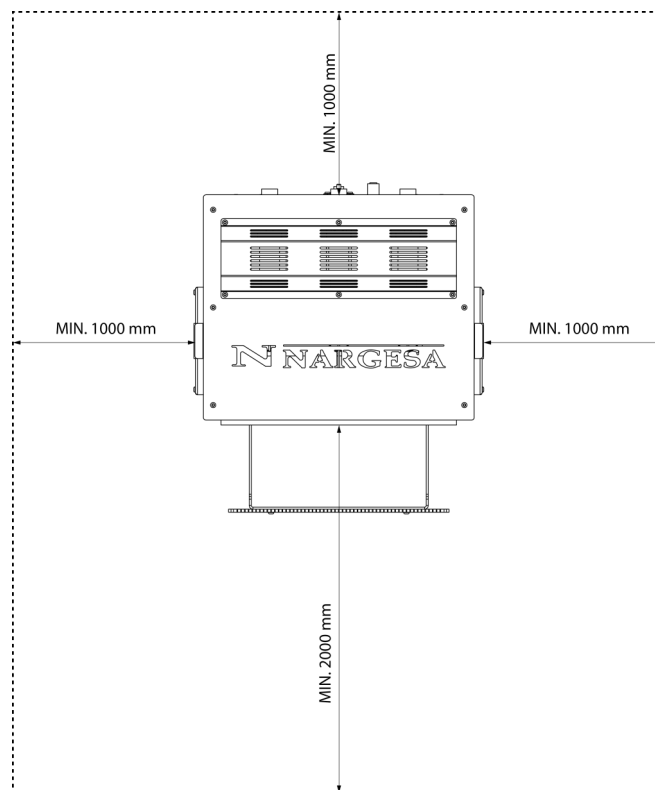

Picture 8. Safety zone

### 5.3. Admissible outside conditions

- Normal temperatura between +5 and +40°C without exceeding an average temperature of +35°C during 24h.
- Relative humidity between 30% and 95% without condensation.

#### 5.4. Setting up

Before putting the furnace into operation:

- Inserting the automatic ignition battery.

1. Unscrew the Automatic ignition button ( ⚡ ) located on the control panel.

2. Insert the battery into the hole so that its positive end is on the outside.

3. Tap tight the Automatic ignition button.

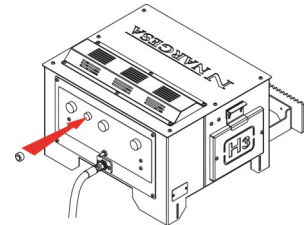
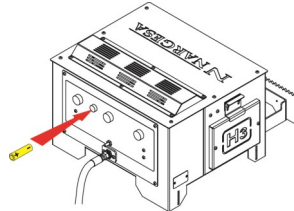
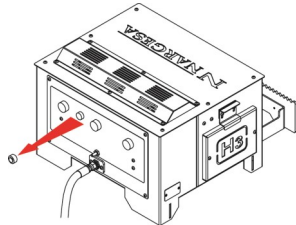

- Connect the **Pressure regulator** to an **Adapter** for the gas cylinder. This adapter is not supplied with the furnace , as this element is different in each country.
- Verify that the maximum gas inlet pressure is less than 25 bars.
- Connect the Adapter to a LPG propane gas cylinder

The **Pressure Regulator** and **Gas Hose** supplied by Nargesá will always be used

#### 5.5. Openings

There are two side openings to work with longer materials.

To remove the **Doors**, move the **Lock up** and pull the **Door** out of position. Leave the Closure in its original position.

To place the **Side door**, move the **Latch upwards** and place the **Door** in the lateral opening, press until it stops and lower the **Latch** to its original position.

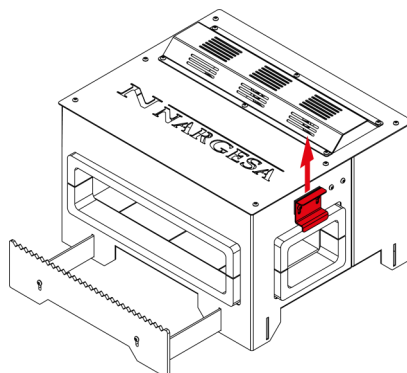

#### WARNING:

To manipulate the **Side doors** it is necessary to turn off the **Burners** and wait 24 hours to make sure that the insulating material is at room temperature

### 5.6. Adjustment of the material support position

The oven is equipped with a **Material holder**, this support serves to hold the material while warming up.

The support point of the material can be regulated by moving the support. The point of support must be adjusted according to the length of the material. For material lengths bigger than 800mm, use an external support.

The **Material holder** can be placed in any of the three **Openings**.

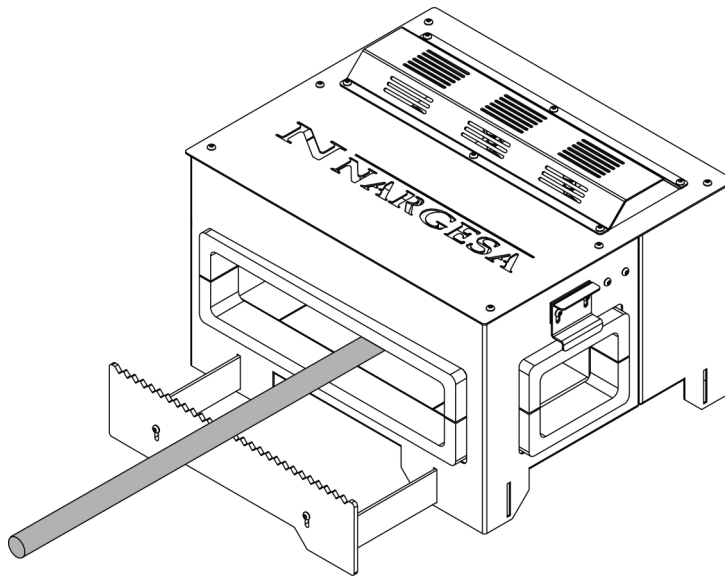

*Picture 9. Support of material*

### 5.7. First set up of furnace

For the first start-up of Nargesa gas furnaces, the automatic ignition provided is not used. We will use an external device to light the burner flame. For example a long lighter or a blowtorch.

**\* The Adapter (C) for the gas bottle is not supplied with this furnace, since each country uses different adapters. The Adapter will have to be equipped with a left 21.8 male thread. (L)**

To proceed to the propane furnace ignition we will follow the following steps:

1. Check that the **Gas Valves (A)** are completely closed.

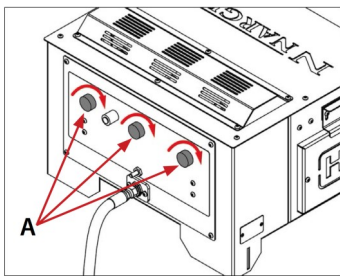

2. Check that the **combustion chamber (B)** is cleared off from any element.

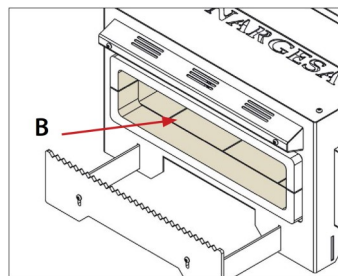

3. Connect the pressure regulator to the **\*Adapter (C)**, and this to the gas bottle.

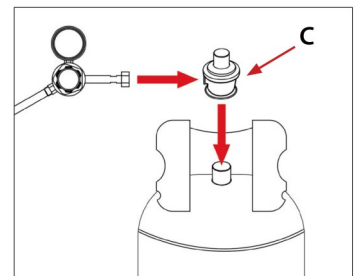

4. Verify that all gas connections between the bottle and the oven are connected correctly and that there are no leaks.

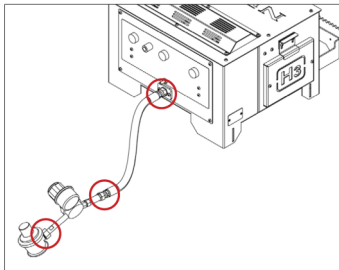

5. Check that the working pressure of the gas is between 0.2 and 0.5 bar.

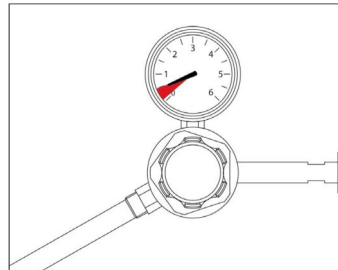

6. Open Gas Valve 1, a few degrees.

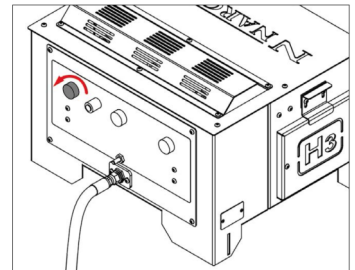

7. Press the **thermocouple button** (🔥)

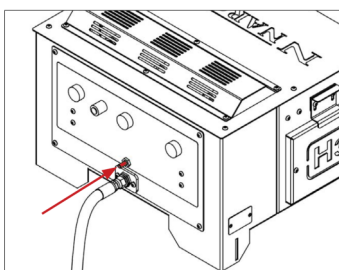

8. Turn on the gas that comes out of the burner. **Important:** never put your hands in the combustion chamber to ignite the gas.

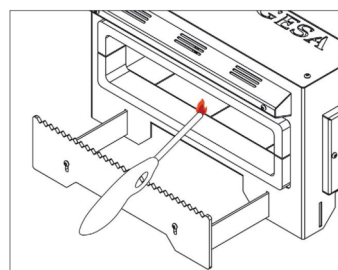

9. When the burner ignites, wait 20 seconds and stop pressing the Thermocouple button.

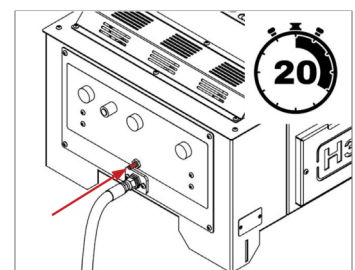

10. Open Gas Valve 1 progressively to the maximum.

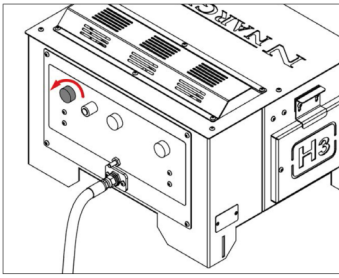

11. Increase the gas pressure progressively up to 1 bar.

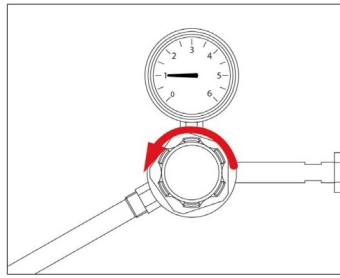

12. Open Gas Valve 2 progressively to the maximum. If the model is H2.

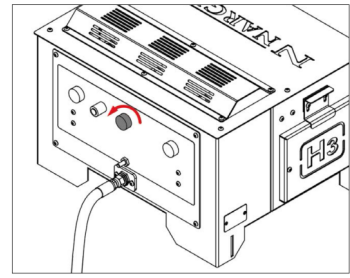

13. Open Gas Valve 3 progressively to the maximum. If the model is H2.

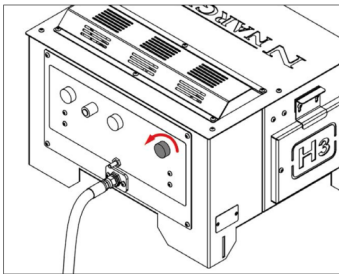

14. After 30 minutes, stop the furnace by closing the gas supply of the Adapter until the flame goes out.

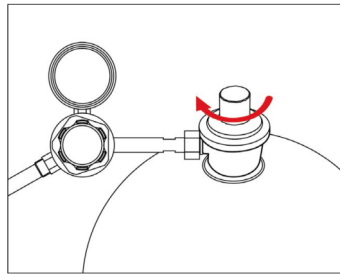

15. Close the gas valves.

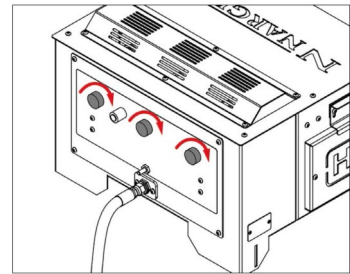

### 5.7. Lighting up the furnace

To proceed with the ignition of the furnace, we'll follow the steps below:

1. Make sure all gas valves are completely closed.
2. Make sure the **Combustión chamber** is empty and free from any other element.
3. Connect the **Adaptor** to the gas bottle.
4. Verify that all gas connections between the bottle and the furnace are correctly connected and that there is no leak.
5. Checkup that the gas work pressure is between 0,1 and 1,5 bars. (Pressure recommended by Nargesa: 0,2 to 1 bar).
6. Open the **Gas valve 1**, a few degrees.
7. Press the **Thermocouple pushbutton** and the **Electronic ignition pushbutton**.
8. When the Burner lits up, reléase the **Electronic ignition button**.
9. Wait 20 seconds and reléase the **Thermocouple pushbutton**.
10. Open the **Gas valve 1** progressively 'til its limit.
11. Progressively increase the gas pressure up to 1 bar. (Pressure recommended by Nargesa: 1 bar).

If you want to work with both burners, once **Burner 1** is turned on:

1. Press the **electronic ignition button**
2. Open the **gas valve 2** progressively up to the maximum.
3. When the burner is ignited, release the **electronic ignition button**
4. Press the **electronic ignition button**
5. Open the **gas valve 3** progressively up to the maximum.
6. When the burner is ignited, release the **electronic ignition button**

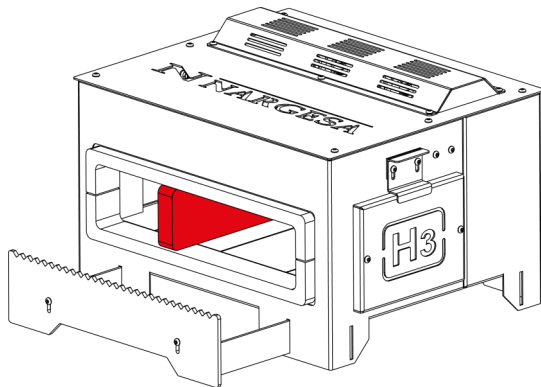

If you want to work with a single burner, it is advisable to place the insulating separator in the middle of the **Combustion chamber**. In this way, the space is divided and the calorific power of the burner is concentrated.

### 5.8. Shutdown the Furnace

To proceed with the shutdown of the furnace:

1. Turn the **Gas valve 3** clockwise until it is completely closed.
2. Turn the **Gas valve 2** clockwise until it is completely closed.
3. Turn the **Gas valve 1** clockwise until it is completely closed.
4. Disconnect the Adapter from the gas bottle.

## 6. POSSIBLE BREAKDOWNS

BREAKDOWN	CAUSE	SOLUTION
<b>The furnace might not ignite</b>	Unproper gas connections	To connect correctly the gas plug and make sure that the <b>Adaptor</b> of the gas bottle is properly fit. See section 5.4
	The <b>Manometer</b> of the Pressure <b>Regulator</b> shows 0	Open the <b>Pressure regulator</b> and the flow of the <b>Adaptor</b> in the gas bottle
	<b>Gas valve 1</b> is closed	Open <b>Gas Valve 1</b> <i>just some degrees</i> .
	<b>Gas Valve 1</b> is way too open	Close a <b>Gas Valve 1</b> <i>a few degrees</i>
<b>Electronic switching does not generate the ignition spark</b>	The spar plug is touching <b>Burner 1</b>	Place the spark plug 4mm away from the <b>Burner 1</b>
	The spark plug is more tan 4mm away from <b>Burner 1</b>	Place the spark plug 4mm from <b>Burner 1</b>
	Inner battery has been exhausted e ha agotado la pila interior	Change the inner battery (AA, 1,5v)
<b>The flame turns to be turbulent.</b>	Excesss of fuel in the blend of air and gas.	Reduce the amount of fuel by closing gradually the <b>Gas Valve 1</b> .
		Reduce the job pressure
	The gas injector is stuck or dirty	Replace the injector
<b>The flame turns orange</b>	Lack of fuel in the bland of air and fuel.	Increase the amount of fuel by opening the <b>Gas Valve 1</b> gradually.
	The gas injector is stuck or dirty	Replace the injector
	The air inlet is dirty	Clean up the furnace air inlet.
<b>The flame goes out of the combustion chamber</b>	Excessive gas pressure	Reduce the gas pressure

**If the problem goes on, please contact our technical assistance in Nargesa**



+34 972568085



+34 620446827



sat2@nargesa.com



sat2.nargesa



## 7. WARNINGS

The H3 furnace is designed so that the operator can adjust the machine and heat the necessary parts with total safety. Any modification of the machine will alter the security that it offers, breaching the certificate of conformity and being able to generate irreparable personal and material damages. Carefully read the **Warning label** on the left side of the furnace.

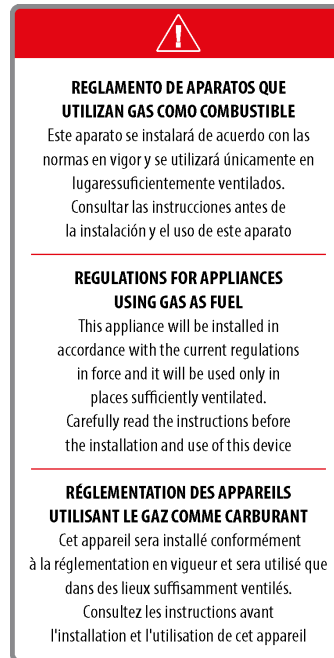

### 7.1. Waste hazards

During the heating of materials some danger situations might occur, which need to be analyzed and prevented.

- Be carefull while introducing and removing material in the machine, in order to prevent any burnt or injury.
- Firmly hold the piece to be inserted or removed to avoid unwanted movements due to the weight of the piece.
- Hold the material by the cold end, never by the hot zone
- Maintain a safe distance between the machine and the operator

### 7.2. Protection elements for the operator

Like elemnts of personal protection, it is mandatory:

- Utilizar gafas y botas de protección homologadas
- To wear thermal gloves for handling the machine and all along the heating processes.
- To wear homologated and approved protective goggles and shoes.

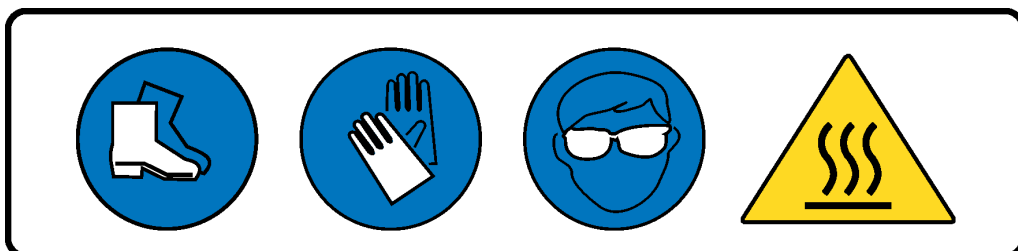

# **Tecnichal Annex**

## **Furnace H3**

---

List of parts

Gas layout

List of parts

100-04-04-003

Nº Despiece

PLANO DE ENSAMBLAJE		Nombre	Fecha
Ref. del ensamble		tesclic32	10/01/2018
<b>FORN H3</b>		Dibujado	Verificado
<p>⚠ Tratamiento Revestimiento</p>		50,00 kg. /Maq.	HORNO H3

Este plano es propiedad de NARGESA S.L. No puede ser reproducido, comunicado a terceros o utilizado para otro fin que no sea el acordado sin el permiso escrito.

Elemento	Miniatura	Nº de pieza	Descripción	CTDAD
1		120-04-04-00057	FRONTAL	1
2		120-04-04-00002	POSTERIOR	1
3		120-04-04-00003	BASE	1
4		120-04-04-00004	TAPA SUPERIOR	1
5		120-04-04-00005	CHAPA CAPOTA	1
7		120-04-04-00007	TAPA REGULACION	1
8		120-04-01-00108	SOSTEN MATERIAL	1
9		120-04-04-00009	FRONTAL SOSTEN	1
10		120-04-04-00010	AISLANTE FRONTAL 30	1
11		120-04-01-00111	AISLANTE LATERAL 1 50	2
12		120-04-04-00012	AISLANTE INFERIOR 30	2
14		120-04-01-00114	AISLANTE LATERAL 20	2
17		120-04-04-00017	AISLANTE POSTERIOR 30	1
18		120-04-04-00018	AISLANTE SUPERIOR 30	1
19		120-04-04-00019	SOPORTE SUPERIOR	1

20		120-04-04-00020	TAPA SUPERIOR QUEMADORES	1
22		120-04-01-00122	TOBERA QUEMADOR	3
23		120-04-01-00123	TOBERA LARGA QUEMADOR	3
24		120-04-01-00124	TOBERA VENTURI	3
25		120-04-01-00125	DIFUSOR	3
26		120-04-01-00126	SOPORTE INYECTOR	3
27		120-04-01-00127	INYECTOR	3
28		120-04-01-00128	REGULADOR CAUDAL AIRE	3
29		120-04-04-00029	COLECTOR GAS	1
30		120-04-01-00130	ANTIROTACION ENTRADA GAS	1
31		040-RRMM-00003	Racor Reducido 1/2'-1/4' Macho Macho	1
32		120-04-04-00032	PUERTA LATERAL	2
33		120-04-01-00133	CUBRE CHAPA PUERTA LATERAL	2
34		120-04-01-00134	AISLANTE PUERTA LATERAL 20	2
35		120-04-01-00135	AISLANTE PUERTA LATERAL 30	2
36		120-04-01-00136	FIJACION PUERTA LATERAL	2

37		120-04-01-00137	SEPARADOR FIJACION PUERTA	2
39		120-04-01-00139	AISLANTE LATERAL 2 50	2
41		120-04-01-00141	Manguera Metálica L=1500mm	1
43		120-04-01-00143	AISLANTE SEPARADOR	1
44		120-04-04-00044	AISLANTE INFERIOR 20 1	1
45		120-04-04-00045	AISLANTE INFERIOR 20 2	1
46		120-04-04-00046	AISLANTE INFERIOR 20 3	1
47		120-04-04-00047	AISLANTE INFERIOR 20 4	1
48		120-04-04-00048	AISLANTE POSTERIOR 20 1	1
49		120-04-04-00049	AISLANTE POSTERIOR 20 2	2
50		120-04-04-00050	AISLANTE SUPERIOR 20 1	1
51		120-04-04-00051	AISLANTE SUPERIOR 20 2	1
52		120-04-04-00052	AISLANTE SUPERIOR 20 3	1
53		120-04-04-00053	AISLANTE SUPERIOR 20 4	1
56		120-04-04-00056	SOPORTE BUGIAS	1
57		122-04-04-001	CALCA H3	1

58		122-04-01-002	PLACA CARACTERISTICAS	1
59		020-D9316Z-M6	TUERCA REMACHABLE RANURADA M6	2
60		020-D934-M6	Tuerca Hexagonal DIN934 M6	14
61		020-I7380-M6X10	Tornillo Allen Abombado ISO 7380 M6X10	4
62		020-I7380-M6X12	TORNILLO ALLEN ABOMBADO ISO7380 M6X12	18
63		020-I7380-M6X6	Tornillo Allen Abombado ISO7380 M6X6	35
64		020-I7380-M6X50	Tornillo Allen Abombado ISO7380 M6X50	2
66		020-D7337-3X8	Remache De Clavo DIN7337 De Al D3X8	2
67		020-D7981-3C5X16	TORNILLO DIN 7981 Ø3.5X16 CABEZA ALOMADA PHILIPS	3
68		020-D7505-4x45	TORNILLO DIN 7505 Ø4x45 CABEZA AVELLANADA PHILIPS	4
69		040-CMH-00003	Codo 90º Macho Hembra TI 1/4'	3
70		040-RG-00002	Racor Giratorio Macho Hembra 1/4'	3
71		040-TVA-00001	Tapon Allen 1/2'	2
72		040-RMM-00002	Racor 1/4" Macho Macho	6
73		040-SHF-00002	SUPLEMENTO HEMBRA FIJO 1/4	3
74		041-GAS-00001	Valvula Aguja H-H 1/4	3

75		041-GAS-00013	ENCENDIDO ELECTRONICO H3	1
76		041-GAS-00003	Bujia de Encendido	3
77		041-GAS-00004-GB	Valvula Seguridad Termopar M-M 1/4	1
78		041-GAS-00005	Codo H-H 1/4	1
79		041-GAS-00006	Tuerca Estrecha 1/4" GAS	5
80		041-GAS-00007	Codo 90º Inox AISI 304 H-H 1"	3
81		041-GAS-00008	Termopar	1
83		041-GAS-00010	Regulador de Propano	1
84		041-GAS-00011	Válvula Antirretorno de Propano	1
86		122-04-01-003	Calca Advertencias Horno	1
87		041-GAS-00014	TUERCA 1/4"	1
88		120-04-01-00157	SEPARADOR TERMOPAR	1
89		120-04-04-00059	Angulo refuerzo	1
90		120-04-04-00060	Chapa angulo refuerzo	1
142		120-04-04-00058	Aislante Frontal 80 con Refuerzo	1



**Gas layout**

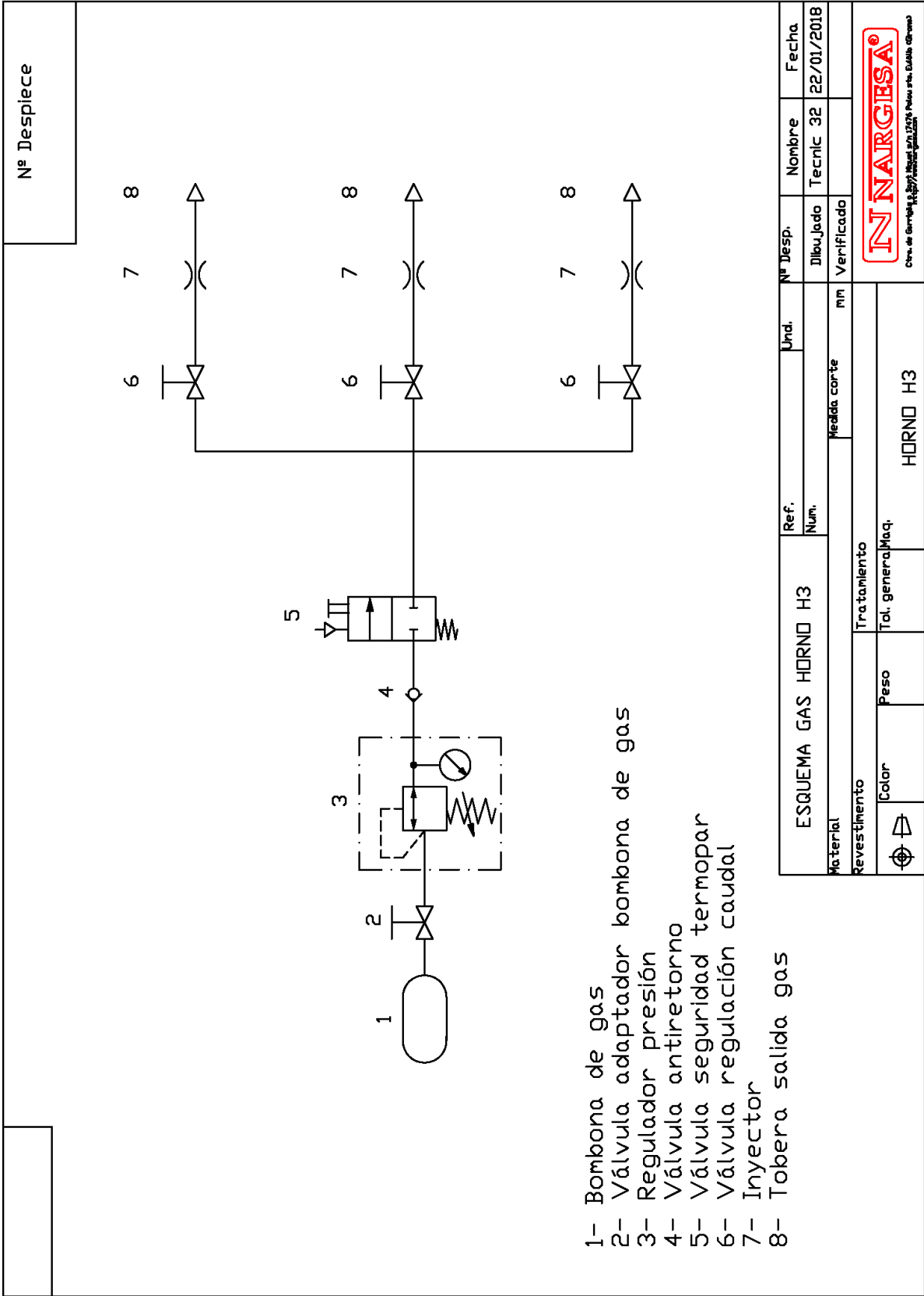

Ref. Num.	ESQUEMA GAS HORNO H3	Nº Desp.	Nombre	Fecha
		Dibujado	Tecníc 32	22/01/2018
Material		Medida corte mm		
Revestimiento		HORNO H3		
Color	Peso	Tratamiento		
		Tal. general/Maq.		

Este plano es propiedad de Prada Nargesa S.L. No podrá ser reproducido, comunicado o utilizado para otro fin que no sea el acordado sin su permiso escrito.

# OUR RANGE OF MACHINERY



IRON WORKERS



SECTION BENDING MACHINES



NON-MANDREL PIPE BENDER



HORIZONTAL PRESS BRAKE



TWISTING/SCROLL BENDING MACHINES



HYDRAULIC PRESS BRAKES



HYDRAULIC SHEAR MACHINES

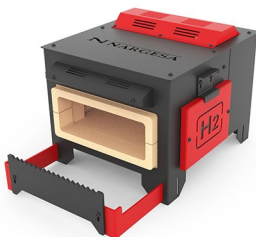

GAS FORGES



IRON EMBOSSING MACHINES



END WROUGHT IRON MACHINES



BROACHING MACHINES



POWER HAMMERS



PRESSES FOR LOCKS