

HIGH PRECISION DIGITAL RADIUS GAUGE



50 years
manufacturing industrial machinery

HIGH PRECISION DIGITAL RADIUS GAUGE

The High precision digital radius gauge allows the user to have a direct and immediate reading of inner and outer radius in a range from 55 to 11.250 millimeters or from 2" to 443" inches.

GET A QUOTE

Please complete the following form. We'll contact you in less than 24 hours.

Business days.

HOW IT WORKS VIDEO

Video on how the Radius Gauge works

SOME OF OUR REMARKABLE CUSTOMERS



TECHNICAL FEATURES

It is really fast and easy to use! It indicates the inner or outer radius of the part we are bending without removing it from the machine and without needing to previously draw and cut a guide template.

This Digital arc meter allows the direct and immediate reading of the values of the inner or outer radius in a wide range of bends.

- > **Comfort:** No need to prepare and cut a template to know the radius of a bend, it is not necessary to remove the part from the machine to measure it either. The digital radius gauge makes the job quicker and easier.
- > **Easy to use:** Its use is simple and the measurement process is very fast. We only have to place the digital radius gauge on the internal or external part of the curve and it will automatically show the value.
- > **Multi-material:** This tool is suitable for any kind of solid and consistent materials like steel, wood or plastic shapes.
- > **High precision:** Its error tolerance over the radius is 0,01mm. Precision will depend on the surface quality of the material to measure.
- > **Application scope:** This digital radius gauge is supplied with three different high precision arc meters. The use of either one or other arch meter offers a measurement range swinging from 55 to 11.250 millimeters and from 2" to 443" inches.
- > **LCD digital screen:** Comfortable reading of all data and low power consumption.
- > **Practical:** It is small and light, we can easily use it for different measurements. It is comfortable, reliable and long lasting.
- > **Storage:** We deliver it inside a stainless briefcase, with an inner foam protection to keep it safe and protect the arc meter when it is not in use. It is comfortable to carry and shock-resistant.
- > **Two units of measure:** We can select either millimeters or inches just by pressing a button.
- > **Perfect for wide radii:** Unlike other manufacturers, the High Precision Arc Meter Nargesa can measure radii up to 12m with maximum precision. For bigger radii, please consult the manufacturer.
- > **Ideal for smaller radii:** The great touch sensor length allows its use even when the inner radius to measure is very tiny.

TECHNICAL SPECIFICATIONS

- > **Measurement scope:**
From 55 to 11.250 mm or from 2" to 443" Inches.
- > **Accuracy:**
0.01
- > **Power supply:**
3V CR2032 Lithium battery
- > **Working temperature:**
0±40°C
- > **Storage and transport temperature:**
-20°C – 60°C
- > **Relative humidity:**
80%

DIMENSIONS AND WEIGHT

Weight of the tool: 0,190 Kg.
100 arc meter weight: 0,246 Kg.
200 arc meter weight: 0,332 Kg.
300 arc meter weight: 0,527 Kg.

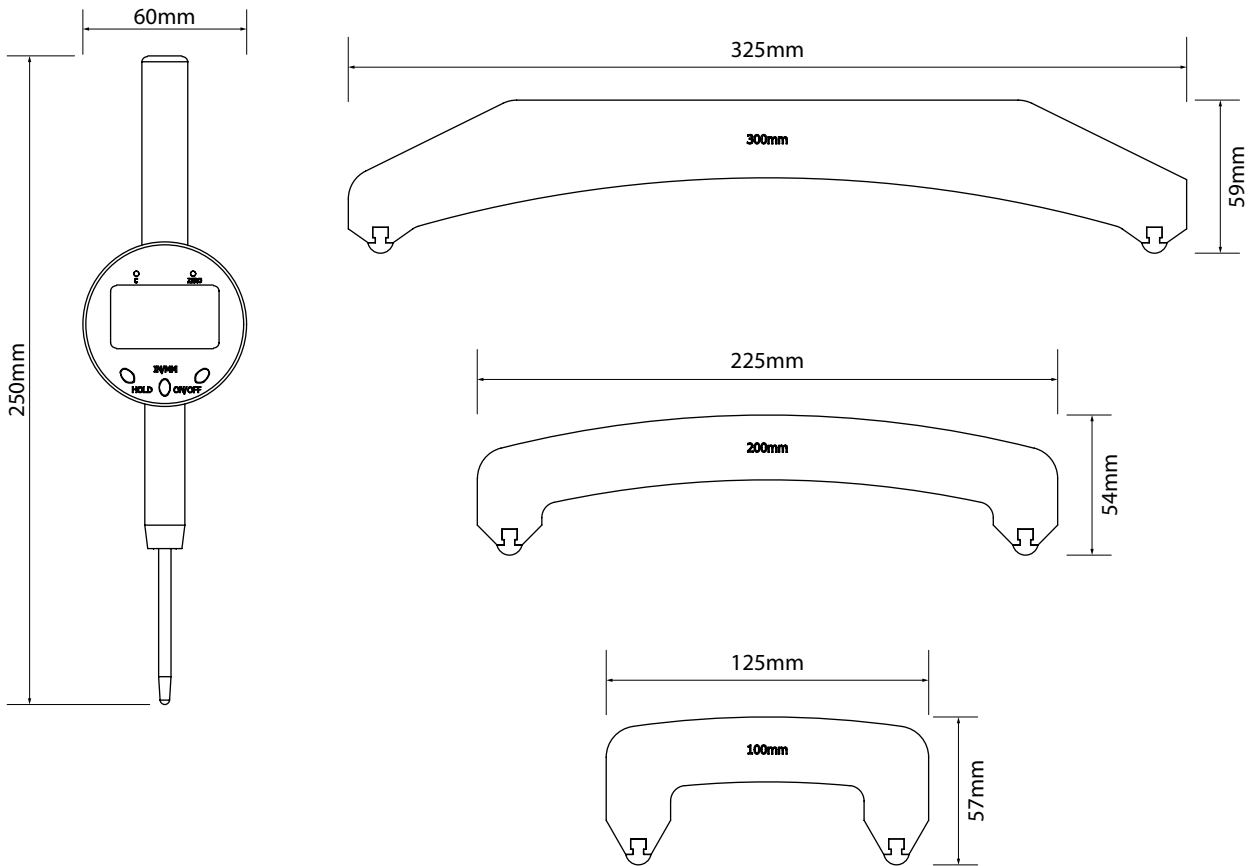

PACKAGING CHARACTERISTICS

- Tariff Item Code: 90173010
- The High precision digital radius gauge and the three Arcs are supplied inside a stainless Steel briefcase is shock-resistant with an inner foam protection.



Width	440 mm
Depth	320 mm
Height	125 mm
Volume	0,17 m ³
Net Weight	1,30 Kg.
Gross Weight	3,50 Kg.

STANDARD ACCESSORIES DELIVERED WITH THE RADIUS GAUGE

100mm Measurement arc



The 100mm High precision arc meter is supplied along with the High precision digital radius indicator.

This tool is attached to the arc meter to measure internal or external radii, amongst the following ranges:

Minimum radius: 55mm or 2"

Maximum radius: 625mm or 25"

200mm Measurement arc



The 200mm High precision arc meter is supplied along with the High precision digital radius indicator.

This tool is attached to the arc meter to measure internal or external radii, amongst the following ranges:

Minimum radius: 125mm or 5"

Maximum radius: 2.500mm or 99"

300mm Measurement arc



The 300mm High precision arc meter is supplied along with the High precision digital radius indicator.

This tool is attached to the arc meter to measure internal or external radii, amongst the following ranges:

Minimum radius: 475mm or 18"

Maximum radius: 11.250mm or 443"

OUR RANGE OF MACHINERY



IRON WORKERS



SECTION BENDING
MACHINES



NON-MANDREL PIPE
BENDER



HORIZONTAL PRESS
BRAKES



TWISTING/SCROLL
BENDING MACHINES



HYDRAULIC PRESS
BRAKES



HYDRAULIC SHEAR
MACHINES



GAS FORGES



IRON EMBOSSING
MACHINES



END WROUGHT IRON
MACHINES



BROACHING MACHINES



POWER HAMMERS



PRESSES FOR LOCKS

WARRANTY

Nargesa High precision digital radius gauge have 1 year warranty provided that the customer registers it in our website. This one encloses any manufacturing default all along this year for components. Any misuse is excluded from this condition. Labor, back and forth shipping and any eventual repair, are not included in this warranty.

Partner companies.



Airpharm

SHIPMENT EVERYWHERE

Nargesa will arrange transport up to final destination, whenever the customers asks for so. There is also the possibility for the customer to arrange the shipment himself with his own agency.

TECHNICAL ASSISTANCE

All our customers have access to technical support quickly and efficiently.

90% of incidences are solved out on the phone, mail, Skype or video-conferencing in less than 24hours. In case of needing presencial technical assistance, we may as well send a technician to the customer's facilities.

Follow us on

PRADA NARGESA, S.L.

Ctra. De Garrigàs a Sant Miquel s/n
17476 Palau de Santa Eulalia (Girona) Spain
Tel. +34 972 568 085

www.nargesa.com

nargesa@nargesa.com



This information might undergo changes